

Standard Duty Deadlatch

For Aluminum Stile Doors

4510 Series

ANSI/BHMA Type E823 (Grade 1)

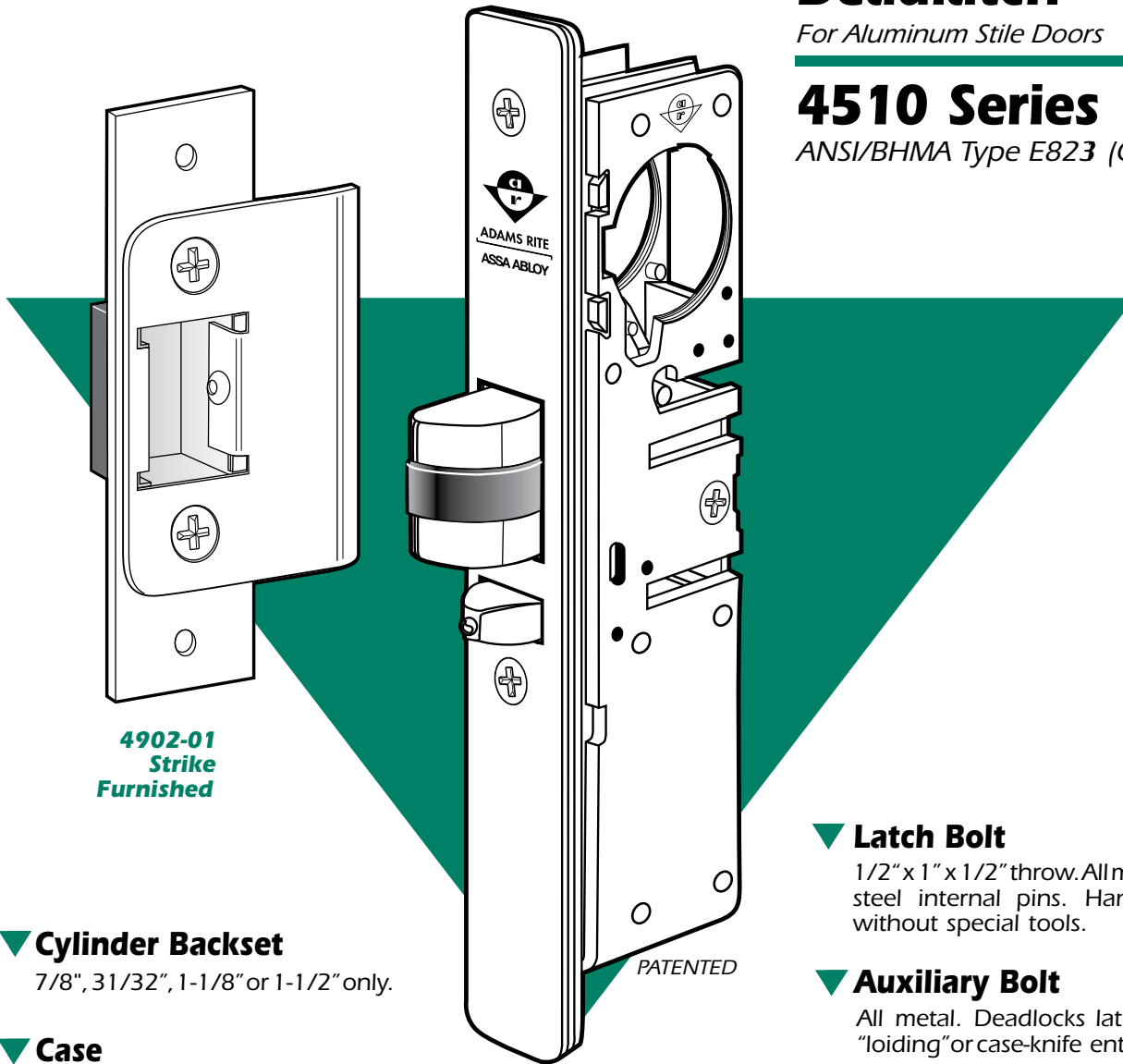

**4902-01
Strike
Furnished**

▼ Cylinder Backset

7/8", 31/32", 1-1/8" or 1-1/2" only.

▼ Case

Steel with corrosion-resistant plating. 1" x 5-13/16" x depth. (Depth varies by backset. See table on back page.)

▼ Function

Flexibility of traffic control during and after business hours is offered by 4510 Series Deadlatches. A reverse turn of the key while bolt is held retracted retains the bolt, to allow two-way traffic for hospitals, banks, stores and other buildings which require free entrance at certain times and exit-only at other times. Interchangeable, without stile modification, with any MS1850A or MS1850S deadbolt of same backset and faceplate shape. (They do not, however, provide the same maximum security level as the MS® Deadbolt.)

▼ Latch Bolt

1/2" x 1" x 1/2" throw. All metal with hardened steel internal pins. Handing is reversible without special tools.

▼ Auxiliary Bolt

All metal. Deadlocks latch bolt to prevent "loiding" or case-knife entry.

▼ Strikes

Standard strike furnished is 4902-01 for flat jamb where door closes flush or nearly flush. Also available: radius strike for opposite stile in paired doors; longer strike (4901) to cover slot strike of MS® lock; long lip strikes for centerhung doors. (See page SW-29 and Electric Strike section.)

▼ Operation

Turn key or operate handle to retract spring-loaded latch bolt. To hold bolt retracted, push it in and secure by reverse turn of key (see back page). Uses any standard mortise cylinder with MS® cam (see page SW-36).



4510 Series Deadlatch

DIMENSIONS

INCHES
MILLIMETERS

Nominal, subject to tolerance extremes.

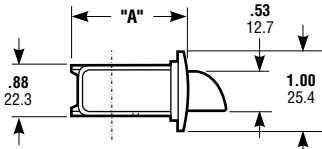

BACKSET	"A"
7/8"	1.51
22.2	38.3
31/32"	1.60
24.6	40.6
1-1/8"	1.76
28.6	44.7
1-1/2"	2.14
38.1	54.3

ARMORED FACEPLATE 1" x 6-7/8"	
FLAT	4510
RADIUS	4511
RADIUS w/WEATHERSTRIP	4511W
LH BEVEL	4512(LH)
RH BEVEL	4512(RH)

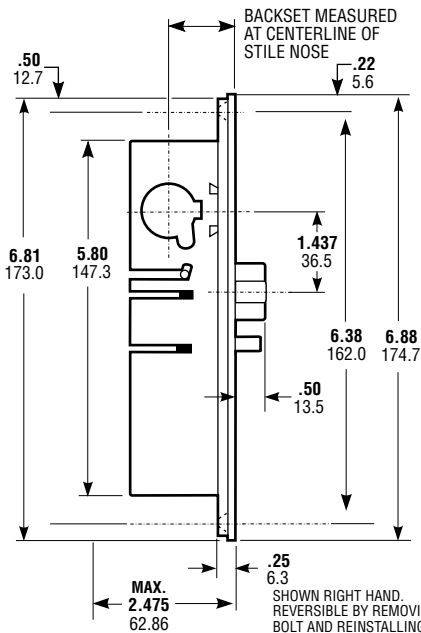

SHOWN RIGHT HAND.
REVERSIBLE BY REMOVING
BOLT AND REINSTALLING
FOR OPPOSITE HAND.

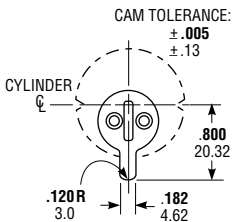

Cylinder Cam

4510 Series Deadlatches are operable by any standard 1-5/32" diameter mortise cylinder with special MS® cam dimensioned as shown. Cylinders with MS® cams can be readily obtained from most cylinder manufacturers. See page SW-36 for cylinder make and trim ring information.

HOW TO ORDER

Specify quantity and the following information.
Order related hardware separately.

Faceplate Shape 0 Flat 1 Radius 1W Radius w/Wstrip 2 Bevel	Backset 1 7/8" 2 31/32" 3 1-1/8" 4 1-1/2"	Handing 5 LH or RHR 6 RH or LHR
---	--	--

4511-36-201-628

Strike Size 1 4.63" (4901)* 2 2.63" (4902)* *See pg SW-29	Strike Shape/Lip Length 01 Flat/Standard Jamb 02 Radius/Standard Stile 17 Flat/Centerhung 4.0" Jamb 21 Flat/Centerhung 4.5" Jamb XX Other Lip lengths See 4901/4902 strikes for options.	Faceplate Finish 628 Clear Anodized 313 Dark Bronze Anod. 335 Black Anodized For other available finishes, contact factory.
---	--	---

INSTALLATION

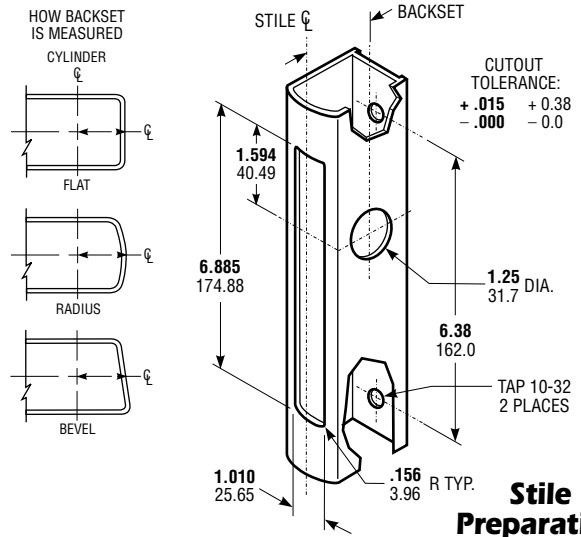

CUTOUT TOLERANCE:
+ .015 + 0.38
- .000 - 0.0

Stile Preparation

Identical to MS1850A Series
(See also prep for 4590 Paddle)

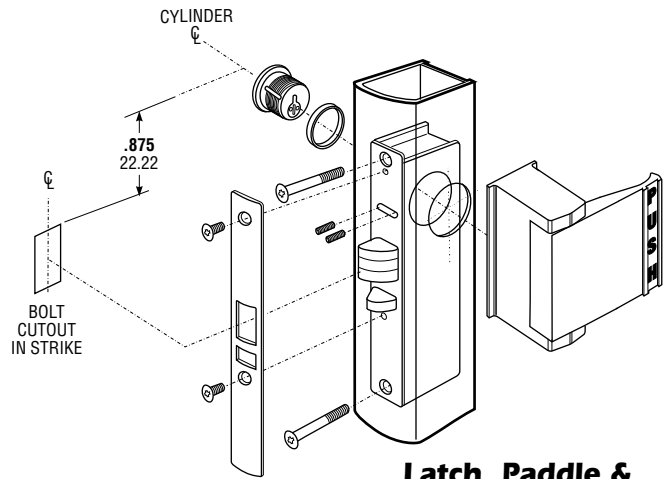

Latch, Paddle & Cylinder Installation

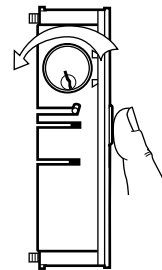

Bolt Holdback

A reverse turn of the key (while bolt is held fully retracted) retains the bolt, allowing the door to be freewinging.

OPTIONS

Backset, Faceplate Shape, Finish, Strike and Handing must be specified when ordering. For Handles, see page SW-30 & 31. For Paddles, see page SW-32 & SW-33.

STANDARD PACKAGE

Individually boxed with strike and machine screws for mounting. Cylinders, paddle or handle available at extra cost. Shipping weight: 1-1/4 lbs. Also available in a 25 unit pack for volume users.