



**AAMA 507-07 THERMAL PERFORMANCE REPORT**

**Rendered to:**

**TUBELITE, INC.**

**SERIES/MODEL: Standard 1-3/4" Medium Stile Double Door**

**TYPE: Swinging Door - Double**

**Report No: B3772.16-116-45**  
**Report Date: 10/27/11**

## AAMA 507-07 THERMAL PERFORMANCE REPORT

Rendered to:

TUBELITE, INC.  
4878 Mackinaw Trail  
Reed City, Michigan 49677

Report No: B3772.16-116-45  
Report Date: 10/27/11  
Simulation Date: 10/27/11

### Project Summary:

Architectural Testing, Inc. was contracted by Tubelite, Inc. to provide U-Factor and Solar Heat Gain Coefficient thermal performance ratings on the Standard 1-3/4" Medium Stile Double Door Swinging Door - Double. The thermal performance ratings were determined in accordance with AAMA 507-07, Standard Practice for Determining the Thermal Performance Characteristics of Fenestration Systems Installed in Commercial Building.

### Reference Documents:

*AAMA 507-07, Standard Practice for Determining the Thermal Performance Characteristics of Fenestration Systems Installed in Commercial Buildings*

*NFRC 100-2010, Procedure for Determining Fenestration Product U-Factors*

*NFRC 200-2010, Procedure for Determining Fenestration Product Solar Heat Gain Coefficient and Visible Transmittance at Normal Incidence*

### Simulation Specimen Description:

**Series/Model:** Standard 1-3/4" Medium Stile Double Door  
**Product Groupings:** 1-3/4" Medium w/o sweep grouped with 1-3/4" Medium w/ sweep.  
**Type:** Swinging Door - Double  
**Frame Material:** Aluminum Framing System  
**Material Finish:** Painted Aluminum  
**Specimen Size:** 1920mm wide by 2090mm high (75-1/2" by 82-3/8")  
**Configuration:** Two vision lites separated by one intermediate vertical  
**Drawing Reference:** Tubelite Standard Doors - 1-3/4" Frame Details

**Tubelite, Inc.**  
**Standard 1-3/4" Medium Stile Double Door - Swinging Door - Double**

**System U-Factor vs. Percentage of Vision Area**

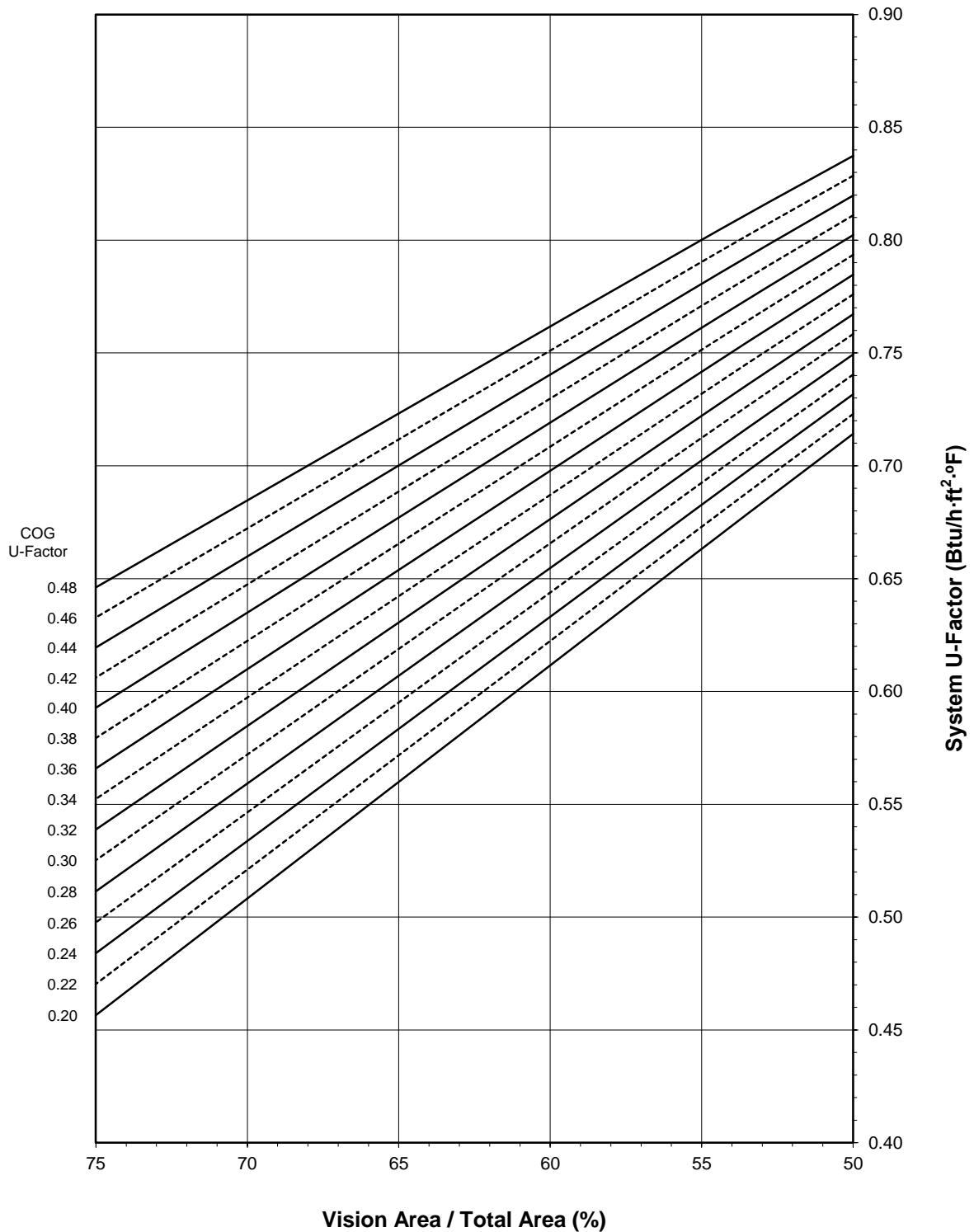

Note: 1 inch Overall - Dual Glazed Glass (0.48-0.20 COG) with Aluminum Spacer

**Tubelite, Inc.**  
**Standard 1-3/4" Medium Stile Double Door - Swinging Door - Double**

**System SHGC vs. Percentage of Vision Area**

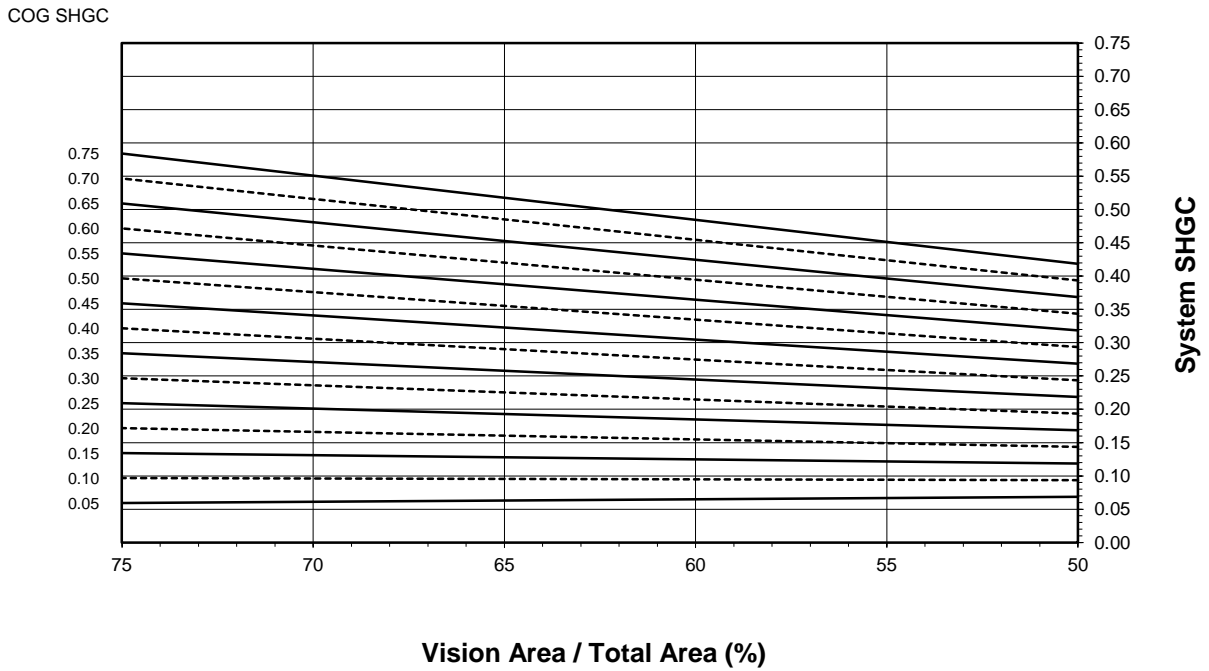

**System VT vs. Percentage of Vision Area**

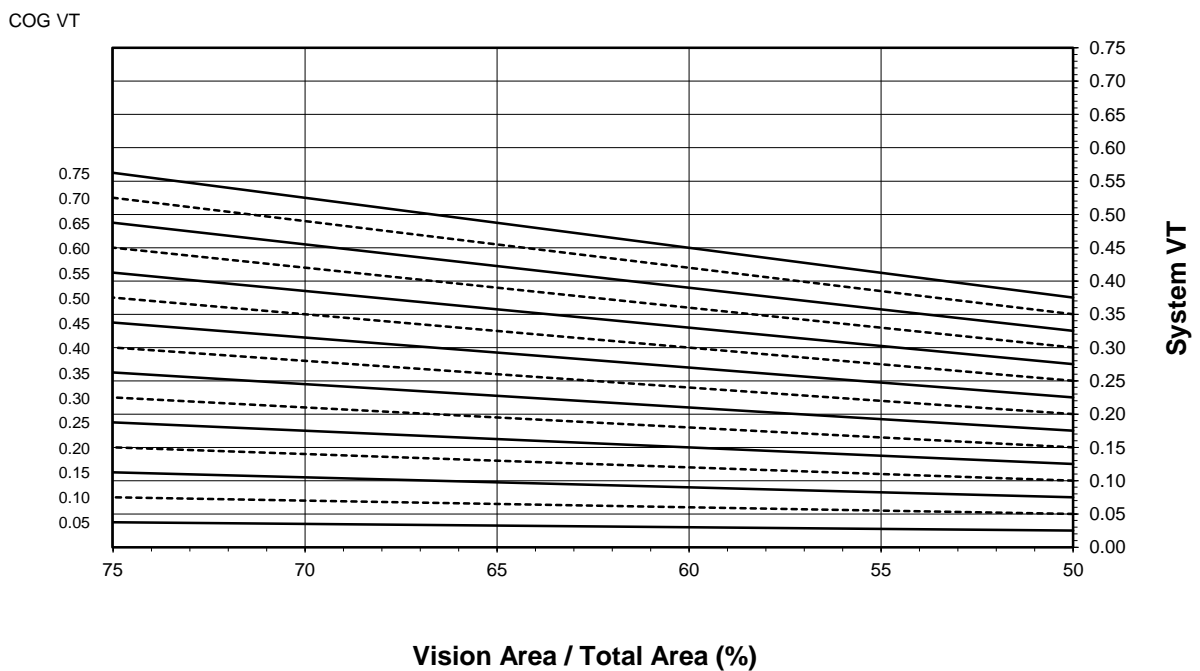

**Tubelite, Inc.**  
**Standard 1-3/4" Medium Stile Double Door - Swinging Door - Double**

**Size Specific U-Factor Matrix\***

Glazing Option	Center of Glass U-Factor	Overall U-Factor
1	0.48	0.80
2	0.46	0.79
3	0.44	0.78
4	0.42	0.77
5	0.40	0.76
6	0.38	0.75
7	0.36	0.74
8	0.34	0.73
9	0.32	0.72
10	0.30	0.71
11	0.28	0.70
12	0.26	0.69
13	0.24	0.68
14	0.22	0.67
15	0.20	0.66

Note: 1 inch Overall - Dual Glazed Glass (0.48-0.20 COG) with Aluminum Spacer

**Size Specific SHGC Matrix\***

Center of Glass SHGC	Overall SHGC
0.75	0.45
0.70	0.43
0.65	0.40
0.60	0.37
0.55	0.34
0.50	0.32
0.45	0.29
0.40	0.26
0.35	0.23
0.30	0.20
0.25	0.18
0.20	0.15
0.15	0.12
0.10	0.09
0.05	0.07

**Size Specific VT Matrix\***

Center of Glass VT	Overall VT
0.75	0.42
0.70	0.39
0.65	0.36
0.60	0.33
0.55	0.30
0.50	0.28
0.45	0.25
0.40	0.22
0.35	0.19
0.30	0.17
0.25	0.14
0.20	0.11
0.15	0.08
0.10	0.06
0.05	0.03

\*Size Specific U-Factor, SHGC, and VT Matrices are based on the standard Swinging Door - Double specimen size of 1920mm wide by 2090mm high (75-1/2" by 82-3/8"). This represents 55.4% Vision Area / Total Area.

Vision Area Data

Option No.	COG U-Factor	COG Temperature	Cross Section	Frame Height	Frame U-Factor	Edge U-Factor	Total Product U-Factor		
							50% Vision Area	NFRC 100-2010	75% Vision Area
							66.21" by 72.08"	75.59" by 82.28"	143.44" by 156.14"
1	0.48	43.7	Ext. Head	6.9645	1.2258	0.5752	0.8374	0.7974	0.6462
			Int. Head	6.9645	1.2258	0.5752			
			Ext. Jamb	6.9056	1.2160	0.5773			
			Int. Jamb	6.9056	1.2160	0.5773			
			Mtg. Rail	10.4191	1.0984	0.5818			
			Ext. Sill	8.2770	1.1346	0.5812			
			Int. Sill	8.2770	1.1346	0.5812			
2	0.46	44.8	Ext. Head	6.9645	1.2257	0.5616	0.8286	0.7876	0.6328
			Int. Head	6.9645	1.2257	0.5616			
			Ext. Jamb	6.9056	1.2159	0.5638			
			Int. Jamb	6.9056	1.2159	0.5638			
			Mtg. Rail	10.4191	1.0982	0.5682			
			Ext. Sill	8.2770	1.1344	0.5675			
			Int. Sill	8.2770	1.1344	0.5675			
3	0.44	45.8	Ext. Head	6.9645	1.2257	0.5481	0.8198	0.7778	0.6195
			Int. Head	6.9645	1.2257	0.5481			
			Ext. Jamb	6.9056	1.2159	0.5503			
			Int. Jamb	6.9056	1.2159	0.5503			
			Mtg. Rail	10.4191	1.0980	0.5546			
			Ext. Sill	8.2770	1.1343	0.5539			
			Int. Sill	8.2770	1.1343	0.5539			
4	0.42	46.8	Ext. Head	6.9645	1.2257	0.5347	0.8110	0.7680	0.6062
			Int. Head	6.9645	1.2257	0.5347			
			Ext. Jamb	6.9056	1.2158	0.5369			
			Int. Jamb	6.9056	1.2158	0.5369			
			Mtg. Rail	10.4191	1.0978	0.5412			
			Ext. Sill	8.2770	1.1342	0.5404			
			Int. Sill	8.2770	1.1342	0.5404			
5	0.40	47.9	Ext. Head	6.9645	1.2257	0.5214	0.8023	0.7582	0.5928
			Int. Head	6.9645	1.2257	0.5214			
			Ext. Jamb	6.9056	1.2158	0.5236			
			Int. Jamb	6.9056	1.2158	0.5236			
			Mtg. Rail	10.4191	1.0976	0.5278			
			Ext. Sill	8.2770	1.1341	0.5270			
			Int. Sill	8.2770	1.1341	0.5270			
6	0.38	48.9	Ext. Head	6.9645	1.2256	0.5082	0.7935	0.7484	0.5794
			Int. Head	6.9645	1.2256	0.5082			
			Ext. Jamb	6.9056	1.2158	0.5104			
			Int. Jamb	6.9056	1.2158	0.5104			
			Mtg. Rail	10.4191	1.0975	0.5146			
			Ext. Sill	8.2770	1.1340	0.5136			
			Int. Sill	8.2770	1.1340	0.5136			

Vision Area Data

Option No.	COG U-Factor	COG Temperature	Cross Section	Frame Height	Frame U-Factor	Edge U-Factor	Total Product U-Factor		
							50% Vision Area	NFRC 100-2010	75% Vision Area
							66.21" by 72.08"	75.59" by 82.28"	143.44" by 156.14"
7	0.36	50.0	Ext. Head	6.9645	1.2256	0.4950	0.7847	0.7385	0.5659
			Int. Head	6.9645	1.2256	0.4950			
			Ext. Jamb	6.9056	1.2158	0.4972			
			Int. Jamb	6.9056	1.2158	0.4972			
			Mtg. Rail	10.4191	1.0973	0.5013			
			Ext. Sill	8.2770	1.1338	0.5002			
			Int. Sill	8.2770	1.1338	0.5002			
8	0.34	51.0	Ext. Head	6.9645	1.2256	0.4820	0.7760	0.7287	0.5524
			Int. Head	6.9645	1.2256	0.4820			
			Ext. Jamb	6.9056	1.2158	0.4842			
			Int. Jamb	6.9056	1.2158	0.4842			
			Mtg. Rail	10.4191	1.0971	0.4882			
			Ext. Sill	8.2770	1.1337	0.4872			
			Int. Sill	8.2770	1.1337	0.4872			
9	0.32	52.0	Ext. Head	6.9645	1.2256	0.4688	0.7672	0.7189	0.5389
			Int. Head	6.9645	1.2256	0.4688			
			Ext. Jamb	6.9056	1.2158	0.4710			
			Int. Jamb	6.9056	1.2158	0.4710			
			Mtg. Rail	10.4191	1.0969	0.4750			
			Ext. Sill	8.2770	1.1336	0.4740			
			Int. Sill	8.2770	1.1336	0.4740			
10	0.30	53.1	Ext. Head	6.9645	1.2256	0.4559	0.7584	0.7091	0.5253
			Int. Head	6.9645	1.2256	0.4559			
			Ext. Jamb	6.9056	1.2157	0.4581			
			Int. Jamb	6.9056	1.2157	0.4581			
			Mtg. Rail	10.4191	1.0968	0.4621			
			Ext. Sill	8.2770	1.1335	0.4610			
			Int. Sill	8.2770	1.1335	0.4610			
11	0.28	54.2	Ext. Head	6.9645	1.2255	0.4429	0.7494	0.6990	0.5115
			Int. Head	6.9645	1.2255	0.4429			
			Ext. Jamb	6.9056	1.2157	0.4451			
			Int. Jamb	6.9056	1.2157	0.4451			
			Mtg. Rail	10.4191	1.0954	0.4474			
			Ext. Sill	8.2770	1.1334	0.4479			
			Int. Sill	8.2770	1.1334	0.4479			
12	0.26	55.2	Ext. Head	6.9645	1.2242	0.4298	0.7405	0.6890	0.4977
			Int. Head	6.9645	1.2242	0.4298			
			Ext. Jamb	6.9056	1.2157	0.4323			
			Int. Jamb	6.9056	1.2157	0.4323			
			Mtg. Rail	10.4191	1.0952	0.4344			
			Ext. Sill	8.2770	1.1333	0.4349			
			Int. Sill	8.2770	1.1333	0.4349			

Vision Area Data

Option No.	COG U-Factor	COG Temperature	Cross Section	Frame Height	Frame U-Factor	Edge U-Factor	Total Product U-Factor		
							50% Vision Area	NFRC 100-2010	75% Vision Area
							66.21" by 72.08"	75.59" by 82.28"	143.44" by 156.14"
13	0.24	56.3	Ext. Head	6.9645	1.2242	0.4170	0.7317	0.6792	0.4841
			Int. Head	6.9645	1.2242	0.4170			
			Ext. Jamb	6.9056	1.2157	0.4194			
			Int. Jamb	6.9056	1.2157	0.4194			
			Mtg. Rail	10.4191	1.0951	0.4215			
			Ext. Sill	8.2770	1.1332	0.4220			
			Int. Sill	8.2770	1.1332	0.4220			
14	0.22	57.3	Ext. Head	6.9645	1.2242	0.4043	0.7230	0.6694	0.4704
			Int. Head	6.9645	1.2242	0.4043			
			Ext. Jamb	6.9056	1.2157	0.4067			
			Int. Jamb	6.9056	1.2157	0.4067			
			Mtg. Rail	10.4191	1.0949	0.4087			
			Ext. Sill	8.2770	1.1331	0.4092			
			Int. Sill	8.2770	1.1331	0.4092			
15	0.20	58.4	Ext. Head	6.9645	1.2242	0.3914	0.7142	0.6595	0.4566
			Int. Head	6.9645	1.2242	0.3914			
			Ext. Jamb	6.9056	1.2158	0.3939			
			Int. Jamb	6.9056	1.2158	0.3939			
			Mtg. Rail	10.4191	1.0948	0.3958			
			Ext. Sill	8.2770	1.1331	0.3963			
			Int. Sill	8.2770	1.1331	0.3963			



Detailed drawings, datasheets, representative samples of test specimens, a copy of this report, or other pertinent project documentation will be retained by Architectural Testing, Inc. for a period of four years from the original test date. At the end of this retention period such materials shall be discarded without notice and the service life of this report by Architectural Testing will expire. Results obtained are simulated values and were secured by using the designated test methods. This report does not constitute certification of this product nor an opinion or endorsement by this laboratory. It is the exclusive property of the client named herein and relates only to the specimen(s) simulated. This report may not be reproduced, except in full, without the written approval of Architectural Testing, Inc.

For ARCHITECTURAL TESTING, INC.:

SIMULATED BY:

REVIEWED BY:

---

Eric Barilar  
Simulation Technician

---

Kevin S. Louder  
Project Engineer

EAB:EAB  
B3772.16-116-45

Attachments (pages): This report is complete only when all attachments listed are included.

Appendix A: Drawings and Bills of Material (23)

### Revision Log

<u>Rev. #</u>	<u>Date</u>	<u>Page(s)</u>	<u>Revision(s)</u>
.01R0	10/27/2011	All	Original Report Issue

All drawings and Bills of Material used in simulating this product are enclosed in this Appendix.

## STANDARD PAIR DOOR BOM -1.75 Frame

**ATI**

**Report #** B3772-116-45

**Date** 10/20/2011

**Simulator** *Eric Barthele*

### FRAME:

Description	QTY	Length	Part number	Material
4500 Jamb 1.3/4" x 4 1/2"	2	82 3/8"	E4544	
Header 1 3/4" x 4 1/2"	1	34 1/4"	E45124	
	1	34 7/23" 80		
Header Door stops & Jambs	2	5/8"	E4531	
Fin Seal Weather pile	30 ft		P1098A	Vinyl
closure open back plate	2		E4543	

### DOOR:

Description	QTY		Narrow P/N	Medium P/N	Wide P/N	Material
Beveled Door Stiles	2	79 13/16"	<del>E0055 - 2 1/8"</del>	E0086- 4"	<del>E0416 - 5"</del>	
Inactive Stile		79 13/16"	<del>E0056 - 2 1/8"</del>	E0087 - 4"	<del>E0417 - 5"</del>	
Astragal Stile		79 13/16"	<del>E1149 - 2 1/8"</del>	E1150 - 4"	<del>E1151 - 5"</del>	
Adjustable Astragal	1	79 13/16"	<del>E1152</del>	E1152	<del>E1152</del>	
Stainless Steel Clip for Adj. Astragal	8		<del>P1539</del>	P1539	<del>P1539</del>	Stainless Steel
Adj. Astragal Pile	2		<del>P938</del>	P938	<del>P938</del>	Vinyl
Door Top Rail	1	29 13/16"	<del>E0255- 2 1/8"</del>	E0054- 4"	<del>E0318 - 5"</del>	
Top Rail Lug	2		<del>P168</del>	P031	<del>P339</del>	AL
Door Botom Rail	1	29 13/16"	<del>E0054- 4"</del>	E0419- 6 1/2"	<del>E0419- 6 1/2"</del>	
Bottom Rail Lug	2		<del>P031</del>	P341	<del>P341</del>	AL
Top Rail & Bottom Rail Tie Rods	2	33 1/4"	<del>P020B</del>	P020	<del>P020</del>	Steel
Washer for Tie Rods	4		<del>P852</del>	P853	<del>P853</del>	steel/AL
Hex nuts for Tie rods	4		<del>S071A</del>	S071A	<del>S071A</del>	Steel

Exterior Glass Stop 1" glass 4  
 Interior Glass Stop 1" glass 4  
 Gasket 35.42  
 Adjustable Wedge Setting Blck 2  
 Self Adhesive Setting Blck 3

Threshold 1  
 Threshold clip 2

~~E0927  
 E0928  
 P0017  
 P1911  
 P1912  
 E0019  
 P679~~

E0927  
 E0928  
 P0017  
 P1911  
 P1912

E0019  
 P679

~~E0927  
 E0928  
 P0017  
 P1911  
 P1912  
 E0019  
 P679~~

Vinyl  
 Polypropylene  
 EPDM

AL

**MATERIAL:**

**E - All E part numbers are AL extrusions**

<b>ATI</b>	
<b>Report #</b>	<u>B3772-116-45</u>
<b>Date</b>	<u>10/20/2011</u>
<b>Simulator</b>	<u>Eric Bordeau</u>

# Standard Doors - Pairs

## Jamb Detail -1 3/4" frame

### Elevations & 1/4 Size Details

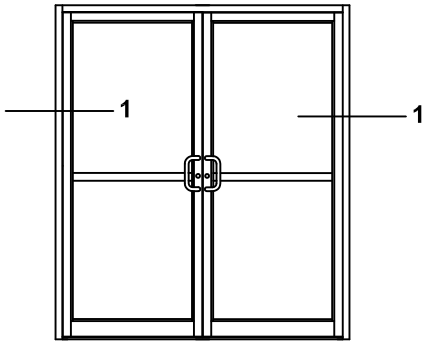

	<b>ATI</b>
Report #	<u>B3772-116-45</u>
Date	<u>10/20/2011</u>
Simulator	<u>Eric Barilko</u>

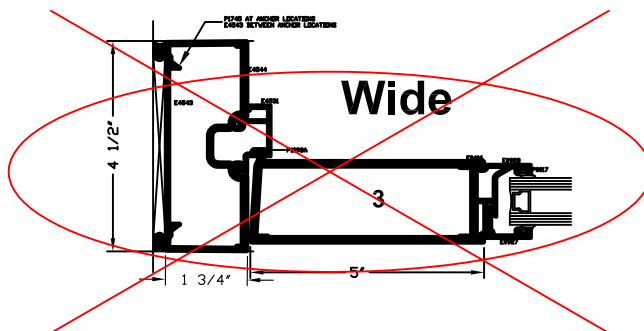
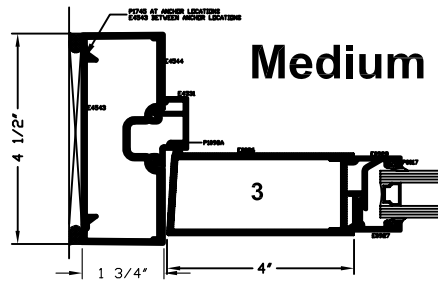
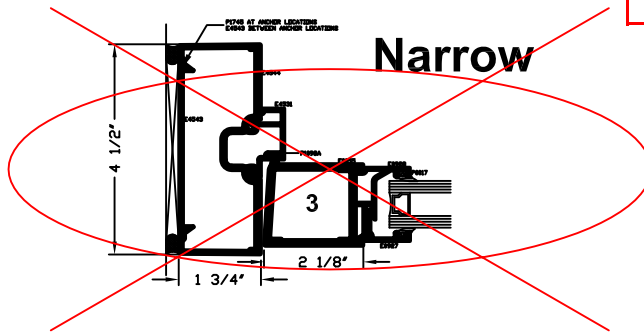

\*SEALANT, ROD, & ANCHORS NOT BY TUBELITE

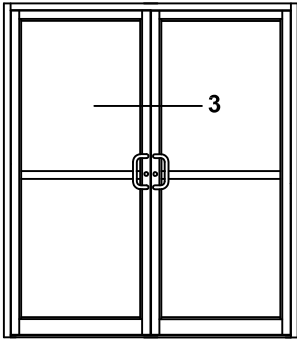

# Standard Doors - Pairs

## Meeting Stile Detail - 1 3/4" Frame

### Elevations & 1/4 Size Details

	<b>ATI</b>
<b>Report #</b>	<u>B3772-116-45</u>
<b>Date</b>	<u>10/20/2011</u>
<b>Simulator</b>	<u><i>Eric Borilac</i></u>

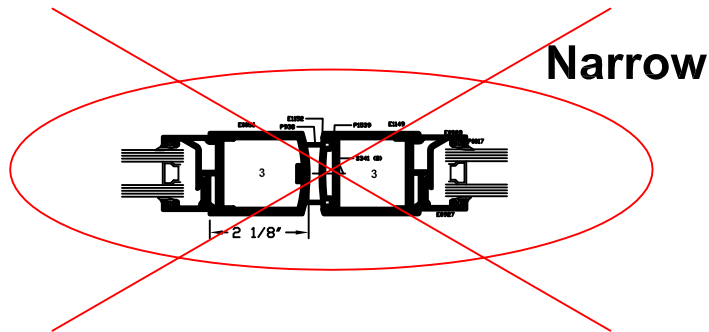
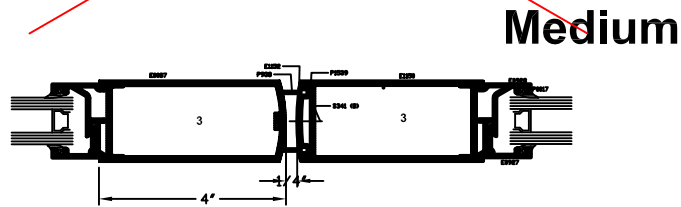
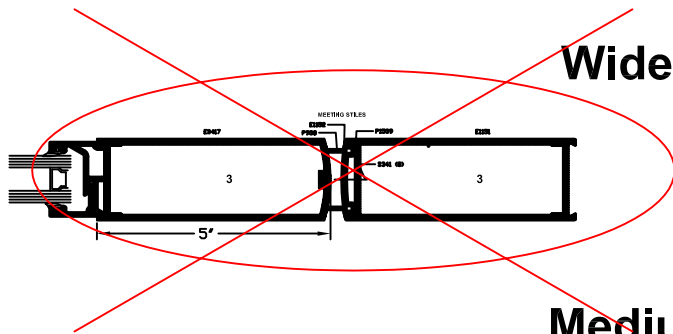

\*SEALANT, ROD, & ANCHORS NOT BY TUBELITE

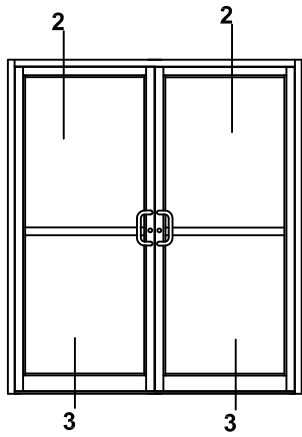

# Standard Doors - Pairs

## 1 3/4" Frame

### Elevations & 1/4 Size Details

**ATI**

Report # B3772-116-45

Date 10/20/2011

Simulator Eric Barilko

**Wide**

**Medium**

**Narrow**

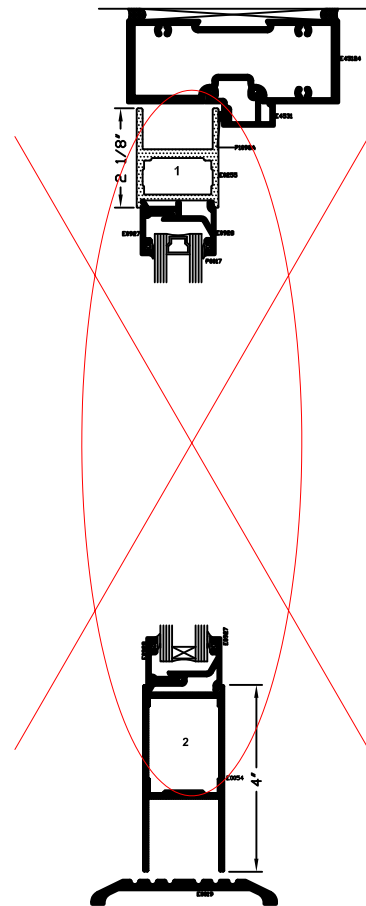
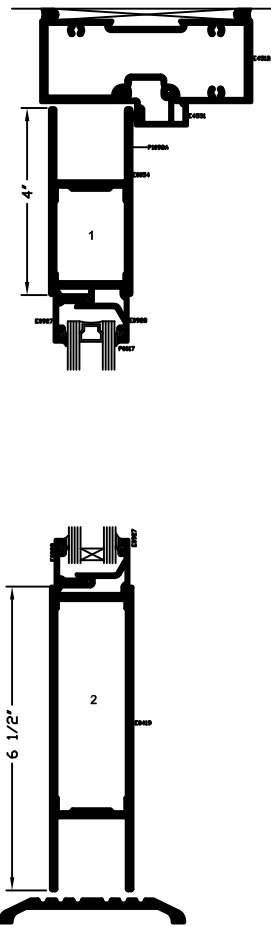
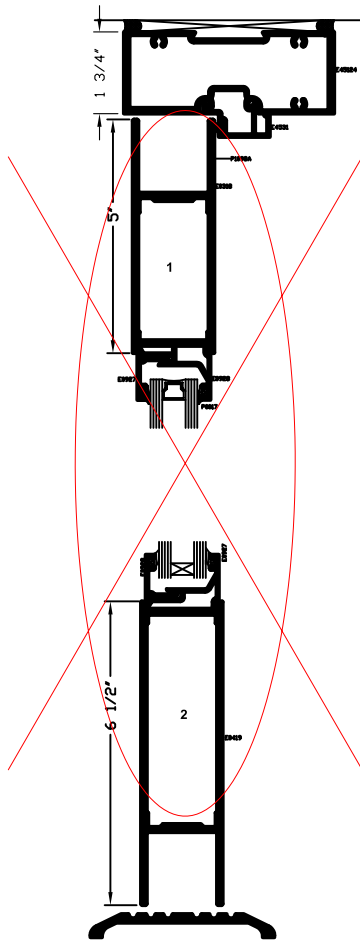

\*SEALANT, ROD, & ANCHORS NOT BY TUBELITE





E45124  
C

**ATI**

Report # B3772-116-45

Date 10/20/2011

Simulator Eric Bahille

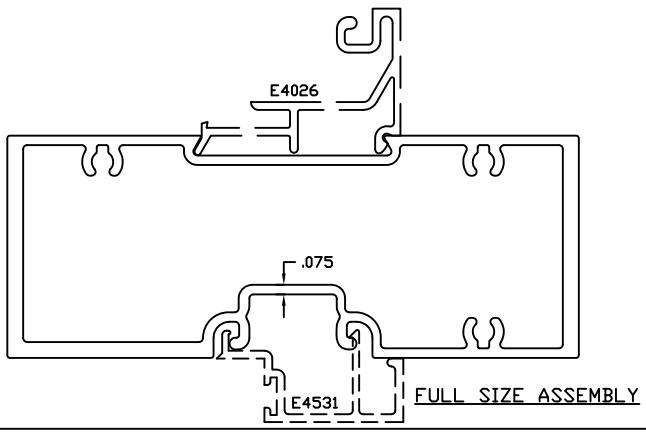
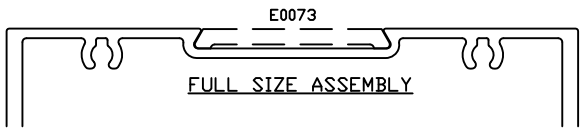
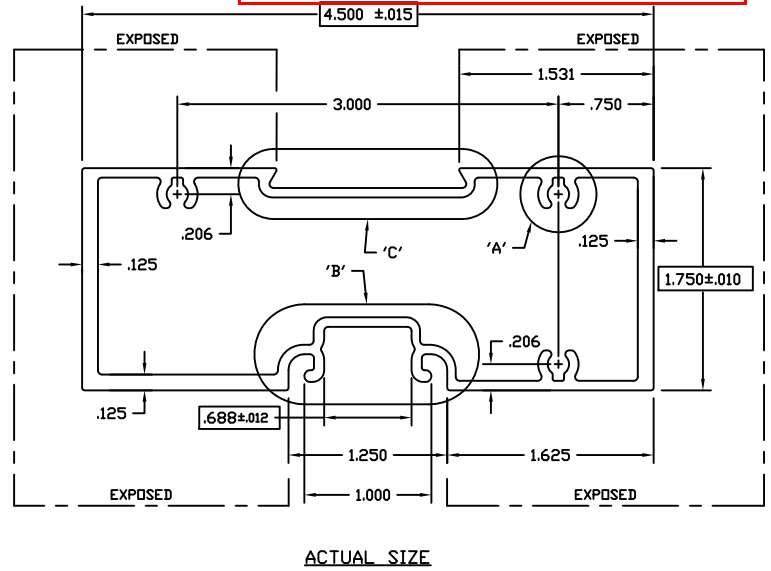
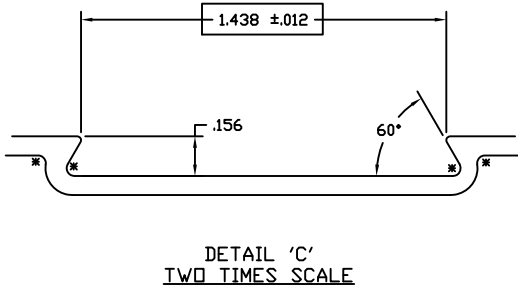
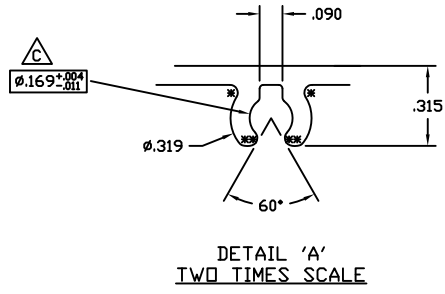
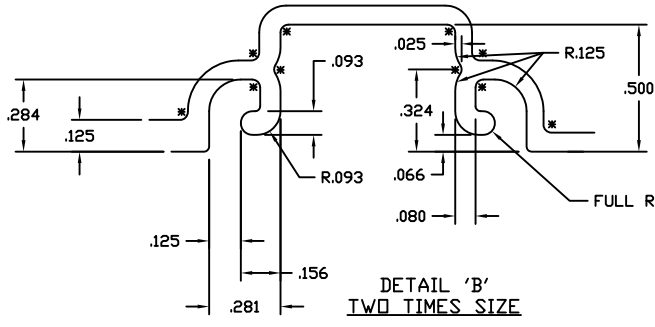

  INDICATES CRITICAL DIMENSION

©2006 TUBELITE INC. ALL RIGHTS RESERVED  
ALUMINUM ASSOCIATION STANDARD TOLERANCES APPLY UNLESS NOTED  
ALL UNSPECIFIED RADII .015  
\* INDICATES .031 RADIUS  
 DENOTES CRITICAL DIMENSION  
ALL DIES PROPERTY OF TUBELITE

**TUBELITE**  
LEADER IN ECO-FRIENDLY OPERATING CURTAINWALL AND ENTRANCE SYSTEMS

3056 WALKER RIDGE NW, SUITE G  
WALKER, MICHIGAN 49544

WALL THK. .075	SECTION H CLASS	MAT'L 6063-T5	RATIO 40:1
PERIMETER DUT (TOTAL) 14.791(29.991)	AREA 1.392	WGT/FT 1.637	
FACTOR 19	CIRCLE SIZE 4.828	INT'L VOLUME N/A	
RXX 1.589	SXX 1.539	IXX 3.516	CXX 2.285
RYY .678	SYY .701	IYY .639	CYY .913

**DOOR HEADER 1 3/4" X 4 1/2"  
E4500 STOREFRONT**

DRAWN BY SRD	DRWG DATE 12/08/02	APP'D BY	DATE APP'D
DWG SCALE NOTED	PRODUCT CODE 160	E45124	REV C

REV	DATE	DESCRIPTION	INTL
EDI729	5-17-93	RELEASE TO TOOLING	KMH
EDI764	7-7-93	REVISE EXTR. # WAS E-45007	KMH
EDI772	7-28-93	RELEASE TO PRODUCTION	KMH
A	11-8-95	REVISED SCREW BOSS	SRK
EDI231	11-8-95	RELEASE TO TOOLING	SRK
B	03/07/03	REVISED GL. POCKET AND REGLET - REDUCED WEIGHT	SRD
	03/07/03	RENAMED E912C15 - RELEASE FOR PRODUCTION	SRD
C	09/15/10	.169 +.004/-011, WAS .162±.004	CRH

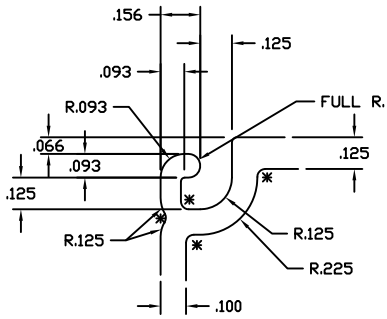

DETAIL 'A'  
TWO TIMES SIZE

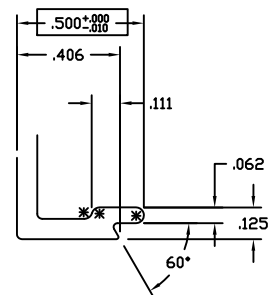

DETAIL 'B'  
TWO TIMES SIZE

**ATI**

Report # B3772-116-45

Date 10/20/2011

Simulator Eric Barilko

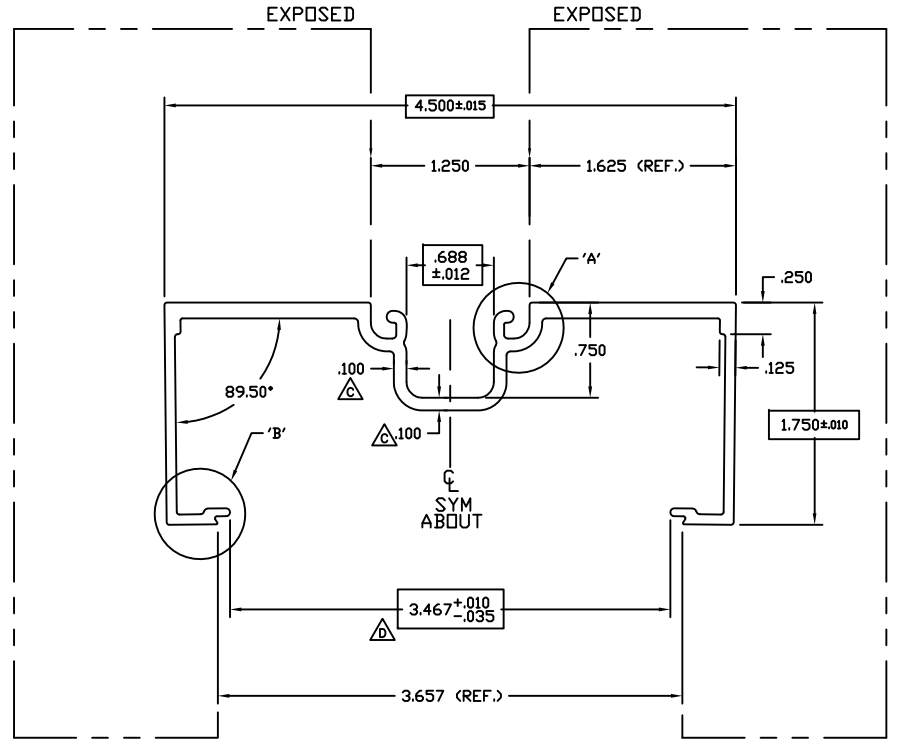

FULL SIZE

INDICATES CRITICAL DIMENSION

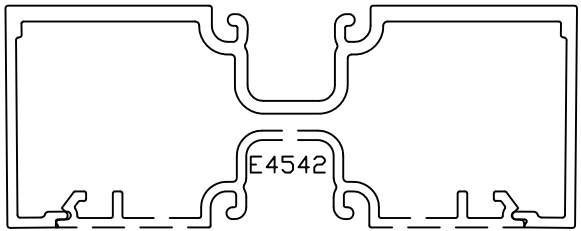

ASSEMBLY

© 2006 TUBELITE INC. ALL RIGHTS RESERVED  
ALUMINUM ASSOCIATION STANDARD TOLERANCES APPLY UNLESS NOTED

**TUBELITE**  
LEADING IN ECO-FRIENDLY EXTRUDED CURTAINWALL AND ENTRANCE SYSTEMS

3056 WALKER RIDGE NW, SUITE G  
WALKER, MICHIGAN 49544

WALL THK	.080	SECTION CLASS	S	MAT'L	6063-T5	RATIO	53:1
PERIMETER (OUT TOTAL)	20.704	AREA	1.030	WGT/FT	1.211		
FACTOR	17	CIRCLE SIZE	4.802	INFTLL VOLUME	N/A		
RXX	1.577	SXX	1.139	IXX	2.562	CXX	2.250
RYY	.543	SYY	.245	IYY	.304	CYY	1.241

DENOTES CRITICAL DIMENSION  
 ALL DIES PROPERTY OF TUBELITE

REV	DATE	DESCRIPTION	INTL
ED2933	6-26-97	REV. .125 WALL CONTINUOUS	SRK
A	03/07/03	REVISED GL. POCKET AND REGLET - REDUCED WEIGHT	SRD
	03/07/03	RENAMED E912C14 - RELEASE FOR PRODUCTION	SRD
B	03/17/04	REVISED WALL THICKNESS IN POCKET AREA AND LEGS	CRH
C	04/08/04	REVISED WALL THICKNESS IN POCKET AREA	CRH
D	03/28-07	REDUCED OPENING FOR BETTER FIT	NIK

OPEN BACK FRAME 1 3/4" X 4 1/2"  
E4500 STOREFRONT

DRAWN BY	SRD	DRWG DATE	12/08/02	APPV'D BY		DATE APPV'D	
BWG SCALE	NOTED	PRODUCT CODE	160	E4544		REV	C



E4531

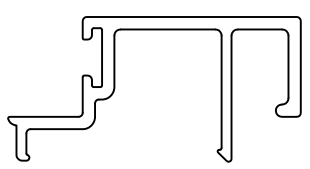
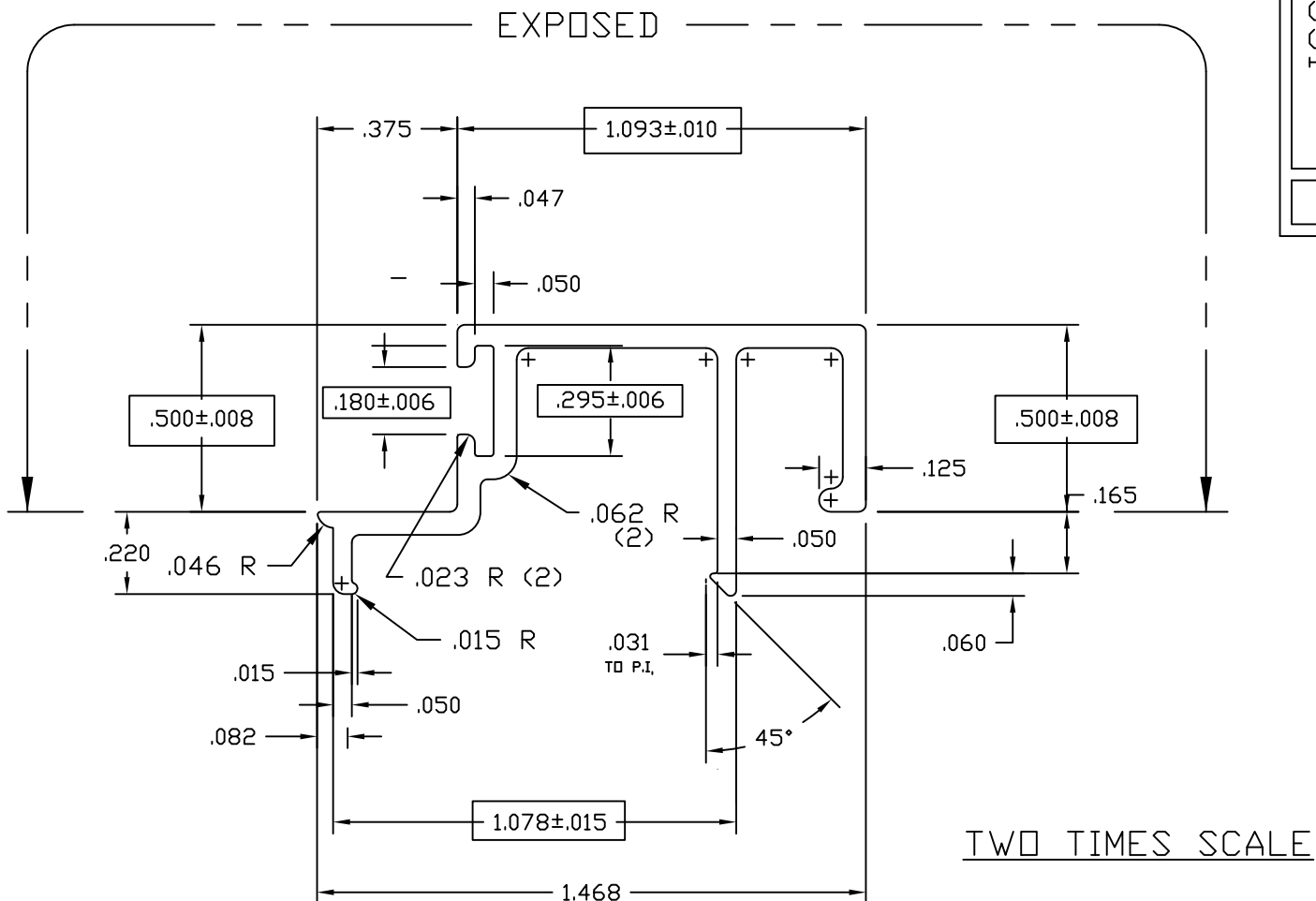

ACTUAL SIZE

**ATI**

Report # B3772-116-45

Date 10/20/2011

Simulator Eric Bahille

USED WITH 4500 SERIES  
REPLACES E-4510  
USE WITH P-1098A WEATHERING

© 2006 TUBELITE INC. ALL RIGHTS RESERVED  
ALUMINUM ASSOCIATION STANDARD  
TOLERANCES APPLY UNLESS NOTED  
ALL UNSPECIFIED RADII .015  
\* INDICATES .031 RADIUS

**TUBELITE®**  
DEPENDABLE  
LEADERS IN ECO-EFFICIENT STOREFRONT,  
CURTAINWALL AND ENTRANCE SYSTEMS

3056 WALKER RIDGE NW, SUITE G  
WALKER, MICHIGAN 49544

WALL THK.	.062	SECTION CLASS	S	MAT'L	6063-T5	RATIO	90
PERIMETER OUT (TOTAL)	6.966	AREA	.203	WGT/FT	.238		
FACTOR	29	CIRCLE SIZE	1.58	INFILL VOLUME	N/A		

RXX	.446	SXX	.049	IXX	.040	CXX	.824
RYY	.218	SYX	.021	IYY	.010	CYY	.461

DOOR STOP 1/2" X 1 3/32"  
E4500 STOREFRONT

DRAWN BY	LS	DRWG DATE	02/07/85	APPV'D BY		DATE APPV'D	
DWG SCALE	NOTED	PRODUCT CODE	160	E4531		REV	

REV	DATE	DESCRIPTION	INTL
	3/28/94	UPDATED SECTION PROPERTIES	TPB
	4/12/99	UPDATED EXPOSED	JEK

☐ DENOTES CRITICAL DIMENSION  
ALL DIES PROPERTY OF TUBELITE





**ATI**  
**Report #** B3772-116-45  
**Date** 10/20/2011  
**Simulator** Eric Barthe

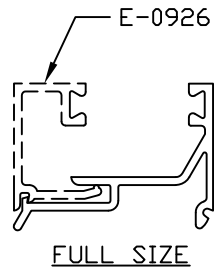
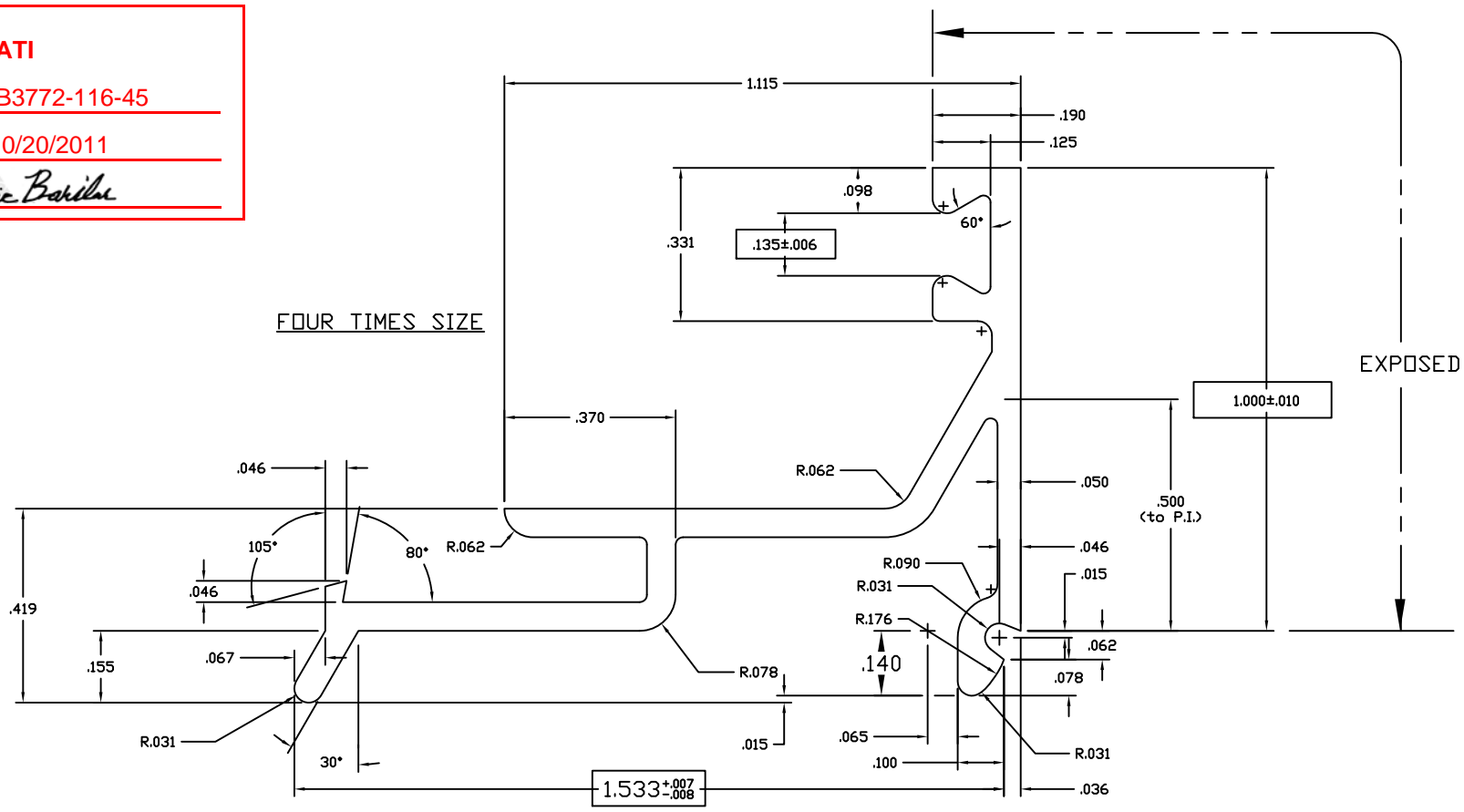

**NOTES:**

- 1) USE E-0927/0928 FOR 1" MAT'L
- 2) USE E-0926/0928 FOR 5/8" MAT'L
- 3) USE GLAZING BEAD P-302 FOR BOTH SIDES OF GLASS OR PANEL

©2006 TUBELITE INC. ALL RIGHTS RESERVED  
 ALUMINUM ASSOCIATION STANDARD TOLERANCES APPLY UNLESS NOTED  
 ALL UNSPECIFIED RADII .015  
 \* INDICATES .031 RADIUS  
 DENOTES CRITICAL DIMENSION  
 ALL DIES PROPERTY OF TUBELITE

**TUBELITE**  
 LEADING IN ECO-FRIENDLY OPERATING CURTAINWALL AND ENTRANCE SYSTEMS  
 3056 WALKER RIDGE NW, SUITE G  
 WALKER, MICHIGAN 49544

WALL THK	.062	SECTION CLASS	S	MAT'L	6063-T5	RATIO	59:1
PERIMETER (OUT TOTAL)	7.540	AREA	.234	WGT/FT	.275		
FACTOR	27	CIRCLE SIZE	1.938	INFILL VOLUME	N/A		
RXX	.302	SXX	.030	IXX	.021	CXX	.701
RYY	.501	SYX	.113	IYY	.059	CYY	1.049

GLASS STOP, 1" HIGH FOR 1" GLASS STOCK DOORS

DRAWN BY	DWG DATE	07/03/84	APPV'D BY	DATE APPV'D
DWG SCALE	NOTED	PRODUCT CODE	100	E0928

REV	DATE	DESCRIPTION	INTL
	10/12/07	REMOVED LEG	RW





E0419  
B

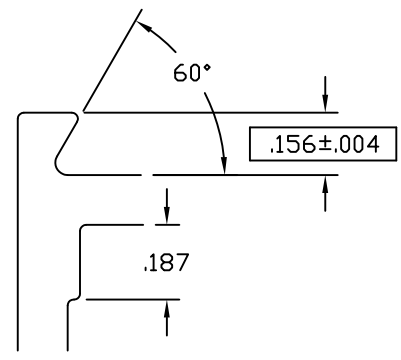
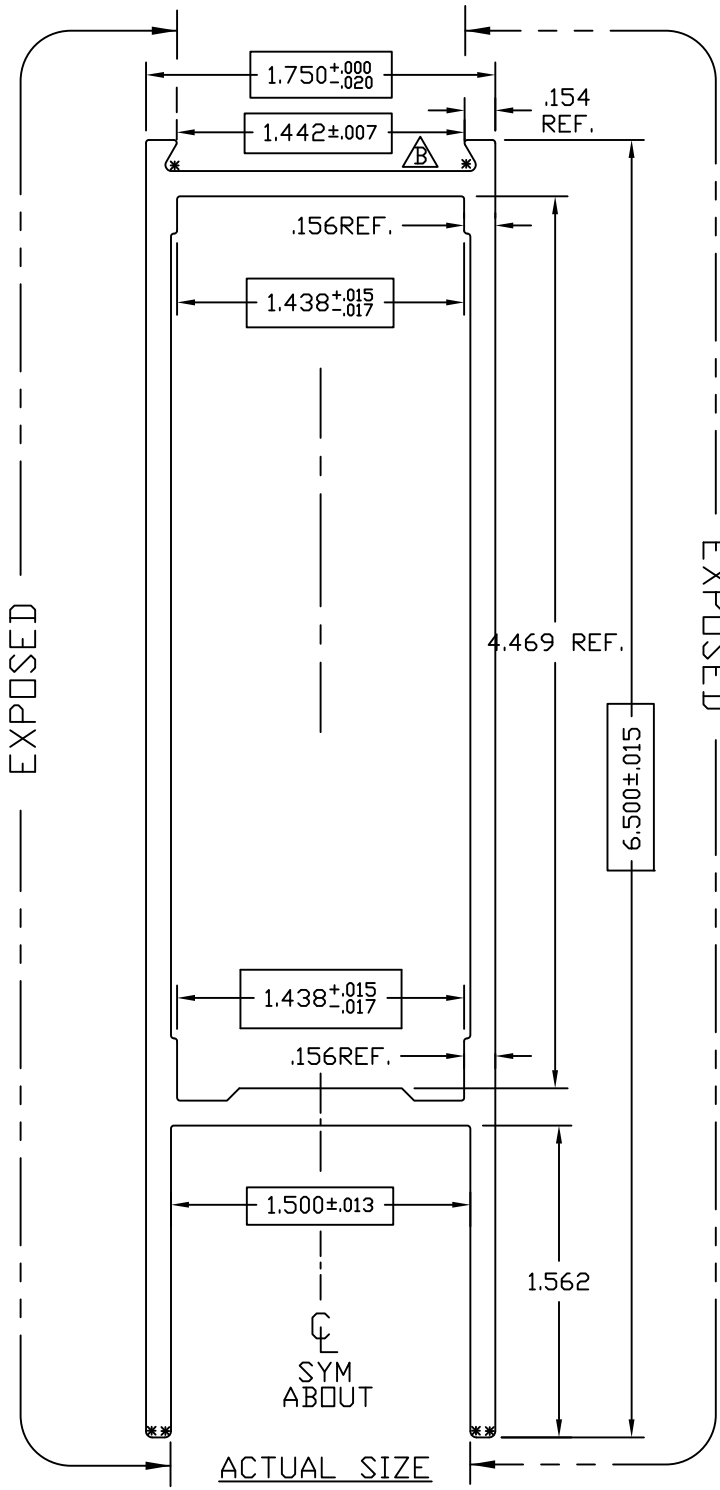

TWO TIMES SCALE

ATI  
 Report # B3772-116-45  
 Date 10/20/2011  
 Simulator Eric Barille

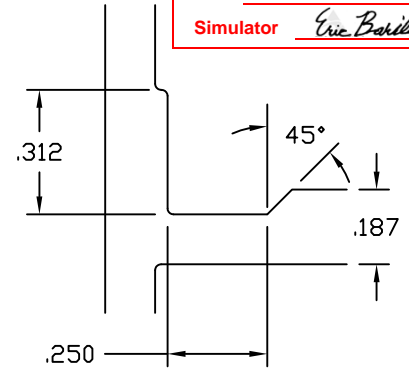

TWO TIMES SCALE

$.125^{+0.003}_{-0.011}$  TYP WALL UNLESS NOTED

SNAP FIT W/E-0437

© 2006 TUBELITE INC. ALL RIGHTS RESERVED  
 ALUMINUM ASSOCIATION STANDARD  
 TOLERANCES APPLY UNLESS NOTED  
 ALL UNSPECIFIED RADII .015  
 \* INDICATES .031 RADIUS

**TUBELITE**  
 DEPENDABLE  
 LEADERS IN ECO-EFFICIENT STOREFRONT,  
 CURTAINWALL AND ENTRANCE SYSTEMS

3056 WALKER RIDGE NW, SUITE G  
 WALKER, MICHIGAN 49544

WALL THK.	NOTED	SECTION CLASS	H	MAT'L	6063-T5	RATIO	26:1
PERIMETER OUT (TOTAL)	19.959(26.440)		AREA	2.084	WGT/FT	2.451	
FACTOR	11	CIRCLE SIZE	6.720	INFILL VOLUME	N/A		

RXX	.747	SXX	1.330	IXX	1.164	CXX	.875
RYY	1.980	SYY	2.447	IYY	8.175	CYY	3.340

HORIZONTAL RAIL 6 1/2" X 1 3/4"  
 CUSTOM DOORS/FRAMES

DRAWN BY	DH	DRWG DATE	04/19/84	APPV'D BY	CRH	DATE APPV'D	12/08/00
DWG SCALE	NOTED	PRODUCT CODE	110	E0419		REV	B

REV	DATE	DESCRIPTION	INTL
A	11/16/00	1.449 WAS 1.438	CRH
B	07/08/03	1.449 +/- .007 WAS 1.449 +.000/- .010	CRH

E0087

D

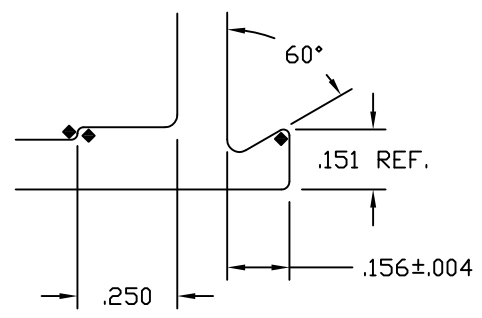
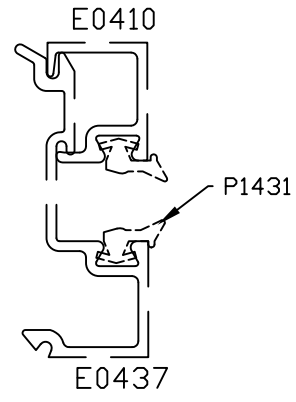
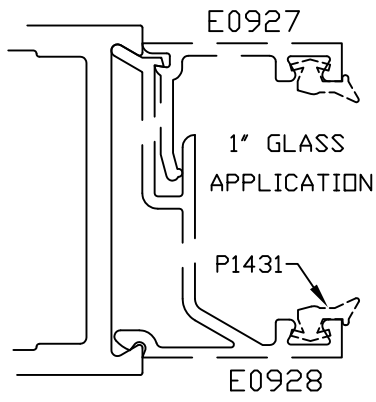
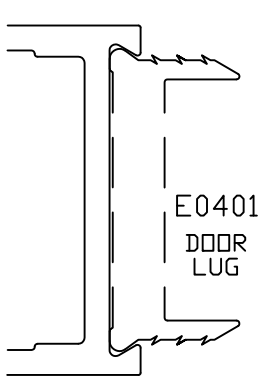
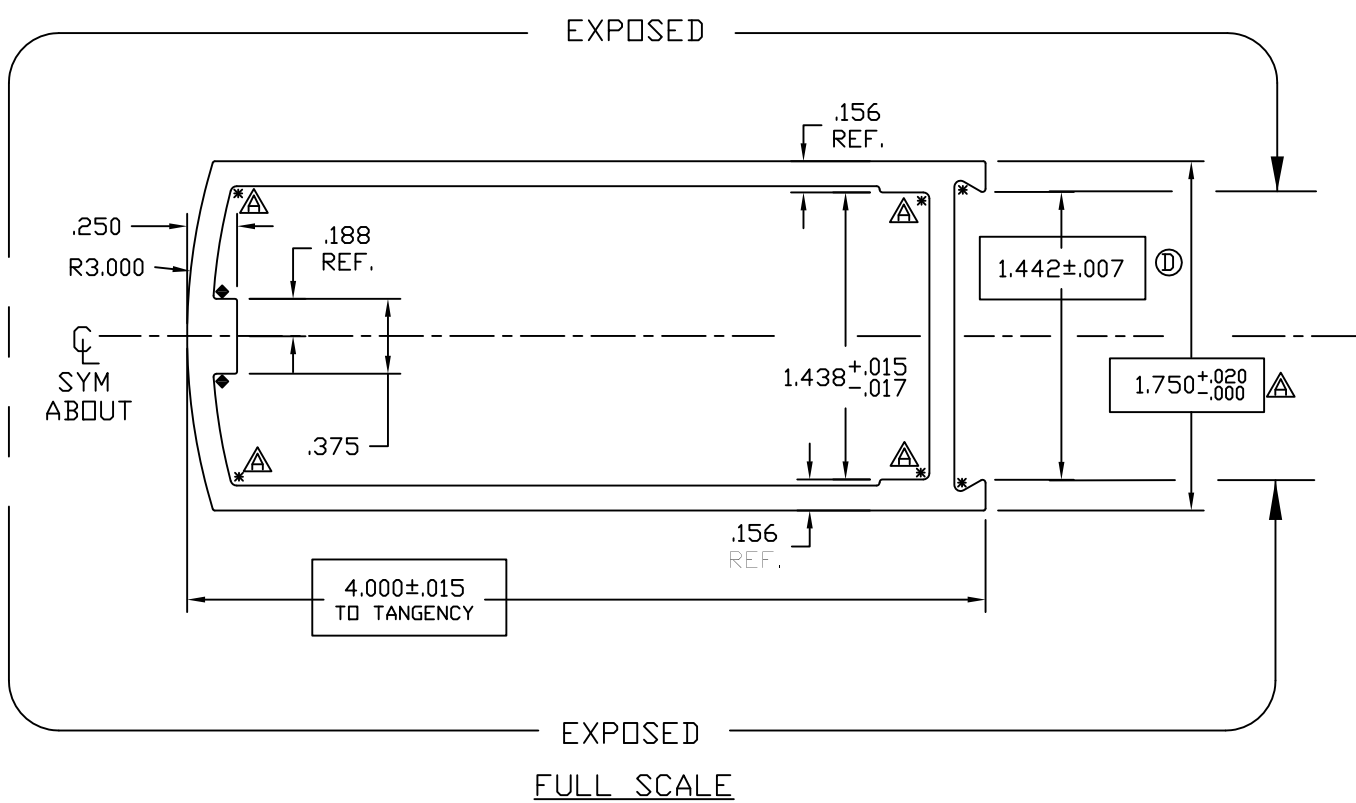

TWO TIMES SCALE

**ATI**  
 Report # B3772-116-45  
 Date 10/20/2011  
 Simulator Eric Boriche

$.125 \begin{smallmatrix} +.003 \\ -.011 \end{smallmatrix}$  TYP WALL

INDICATES CRITICAL DIMENSION  
 SNAP FIT W/E0437(1/4"GLASS) AND E0928(1"GLASS)

© 2006 TUBELITE INC. ALL RIGHTS RESERVED  
 ALUMINUM ASSOCIATION STANDARD TOLERANCES APPLY UNLESS NOTED  
 ALL UNSPECIFIED RADII .015  
 \* INDICATES .031 RADIUS

**TUBELITE**  
 DEPENDABLE  
 LEADERS IN ECO-EFFICIENT STOREFRONT, CURTAINWALL AND ENTRANCE SYSTEMS

3056 WALKER RIDGE NW, SUITE G  
 WALKER, MICHIGAN 49544

WALL THK.	NOTED	SECTION CLASS	H	MAT'L	6063-T5	RATIO	39:1
PERIMETER OUT (TOTAL)	11.673	(21.876)		AREA	1.409	WGT/FT	1.657
FACTOR	13	CIRCLE SIZE	4.246	INFILL VOLUME	/A		

RXX	.716	SXX	.824	IXX	.722	CXX	.875
RYY	1.383	SYX	1.332	IYY	2.696	CYY	2.024

ROUND VERTICAL STILE 1 3/4" X 4"  
 CUSTOM DOOR/FRAMES

DRAWN BY	DH	DRWG DATE	04/04/84	APPV'D BY		DATE APPV'D	
DWG SCALE	NOTED	PRODUCT CODE	110	E0087		REV	D

REV	DATE	DESCRIPTION	INTL
A	08/23/00	1.449 WAS 1.438, +.020/-0.000 WAS ±.010, ADDED .031R	CRH
B	09/29/00	+0.005/-0.010 WAS +.015/-0.000	CRH
C	12/01/00	+0.000/-0.010 WAS +.005/-0.010	CRH
D	04/18/03	±.007 WAS +.000/-0.010	CRH

E0086

E

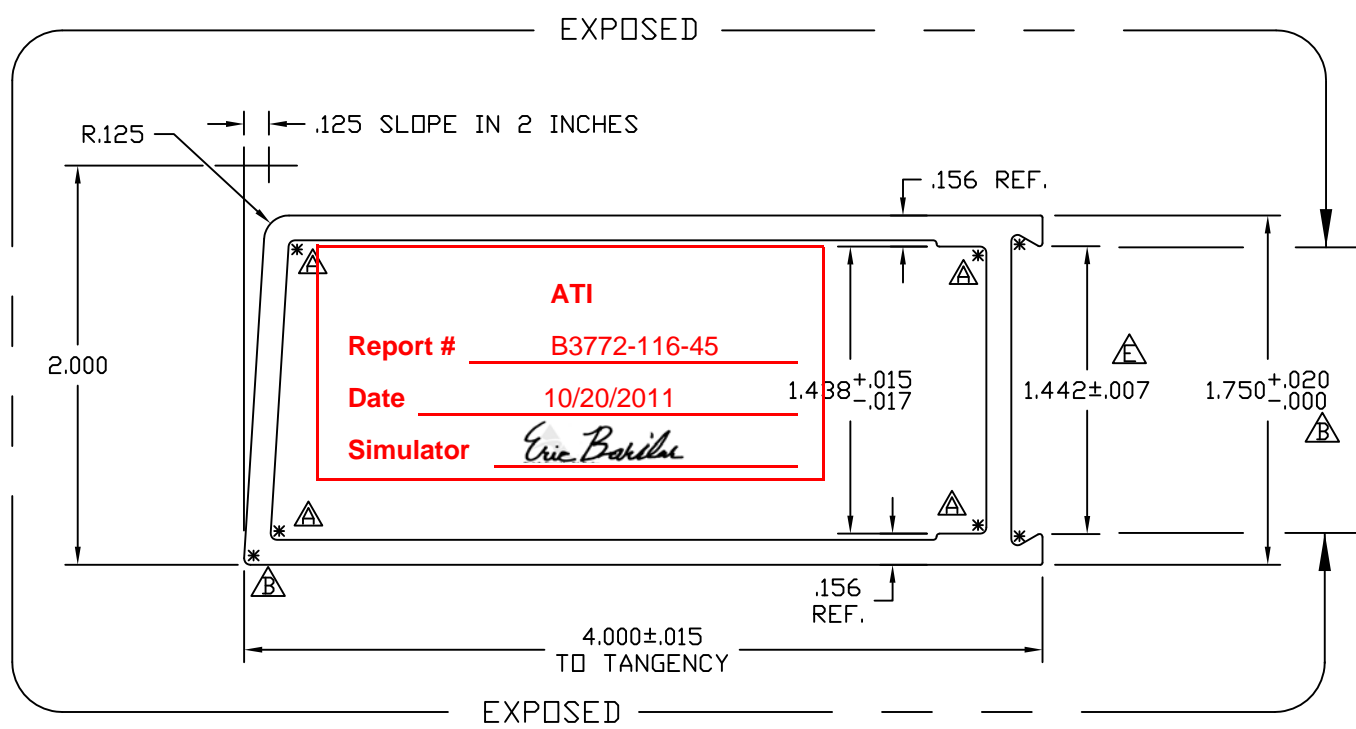

FULL SCALE

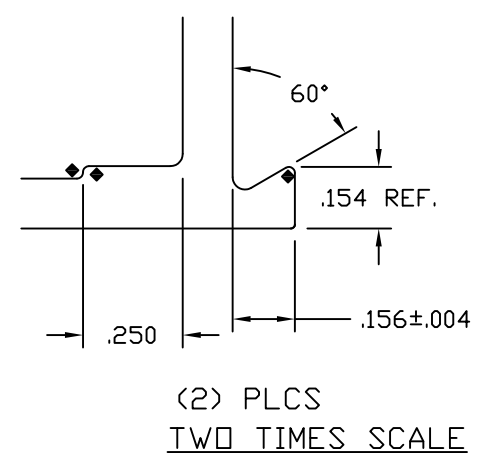
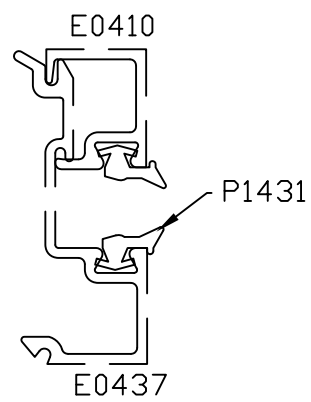
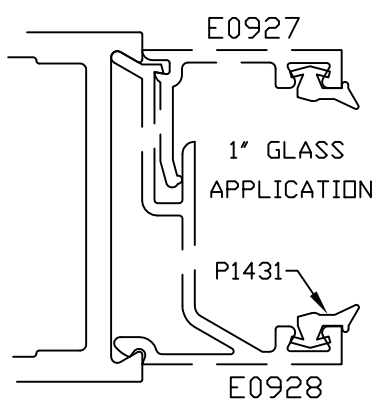
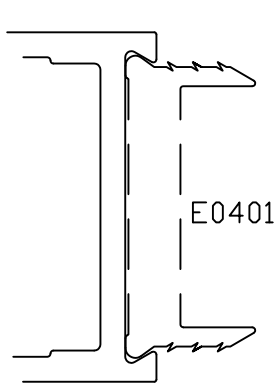

SNAP FIT W/E0437(1/4"GLASS) AND E0928(1"GLASS)  
 .125 (+.003/-0.11) TYP WALL

© 2006 TUBELITE INC. ALL RIGHTS RESERVED  
 ALUMINUM ASSOCIATION STANDARD TOLERANCES APPLY UNLESS NOTED  
 ALL UNSPECIFIED RADII .015  
 \* INDICATES .031 RADIUS

**TUBELITE**  
 DEPENDABLE  
 LEADERS IN ECO-EFFICIENT STOREFRONT, CURTAINWALL AND ENTRANCE SYSTEMS

3056 WALKER RIDGE NW, SUITE G  
 WALKER, MICHIGAN 49544

WALL THK.	NOTED	SECTION CLASS	H	MAT'L	6063-T5	RATIO	40:1
PERIMETER OUT (TOTAL)	11.757(21.761)		AREA	1.374	WGT/FT	1.615	
FACTOR	13	CIRCLE SIZE	4.360	INFILL VOLUME	N/A		

RXX	.728	SXX	.824	IXX	.728	CXX	.884
RYY	1.368	SYX	1.270	IYY	2.571	CYY	2.024

BEVELED VERTICAL STILE 1 3/4" X 4"  
 CUSTOM DOORS/FRAMES

DRAWN BY	DLH	DRWG DATE	04/04/84	APPV'D BY		DATE APPV'D	
DWG SCALE	NOTED	PRODUCT CODE	110	E0086		REV	E

REV	DATE	DESCRIPTION	INTL
A	7/7/00	1.449 WAS 1.438, REV. TOL ON 1.750	CRH
		REMOVED .156 X .250 PAD AREA AND ADDED .031 RADII	
B	08/23/00	1.750 +.020/-0.000 WAS +.000/-0.020, ADDED .031 R	CRH
C	09/29/00	+0.005/-0.010 WAS +.015/-0.000	CRH
D	12/1/00	+0.000/-0.010 WAS +.005/-0.010	CRH
E	01/22/02	1.442+/-0.007 WAS 1.449+0.000/-0.010	CRH

E0054  
C

**ATI**  
**Report #** B3772-116-45  
**Date** 10/20/2011  
**Simulator** Eric Barila

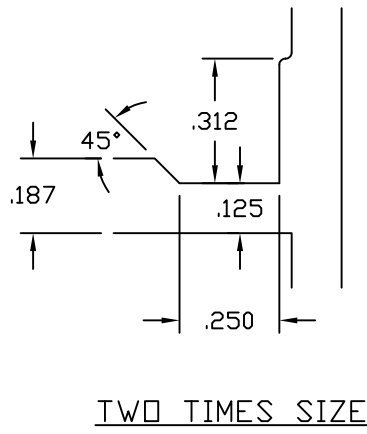
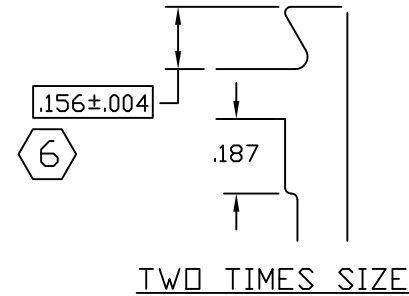
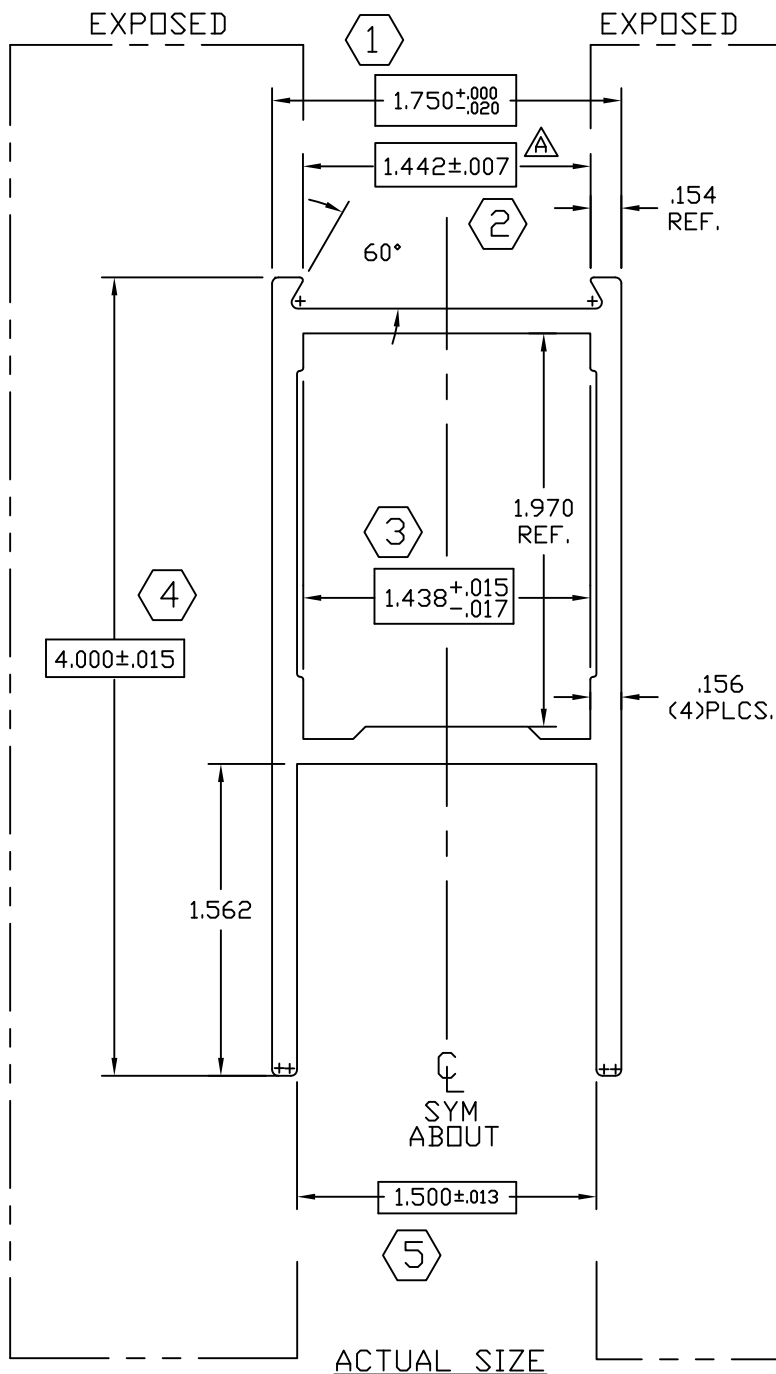

7 SNAP FIT WITH E-0437  
.125 +.003 / -.011 TYP WALL UNLESS NOTED

© 2006 TUBELITE INC. ALL RIGHTS RESERVED  
ALUMINUM ASSOCIATION STANDARD  
TOLERANCES APPLY UNLESS NOTED  
ALL UNSPECIFIED RADII .015  
\* INDICATES .031 RADIUS

**TUBELITE**  
**DEPENDABLE**  
**LEADERS IN ECO-EFFICIENT STOREFRONT,  
CURTAINWALL AND ENTRANCE SYSTEMS**

3056 WALKER RIDGE NW, SUITE G  
WALKER, MICHIGAN 49544

WALL THK.	NOTED	SECTION CLASS	H	MAT'L	6063-T5	RATIO	38:1
PERIMETER OUT (TOTAL)	14.972	(22.036)	AREA	1.460	WGT/FT	1.715	
FACTOR	13	CIRCLE SIZE	4.352	INFILL VOLUME	N/A		

RXX	1.153	SXX	.890	IXX	1.941	CXX	2.182
RYY	.717	SYX	.858	IYY	.751	CYY	.875

HORIZONTAL RAIL 4" X 1 3/4"  
STOCK DOORS

DRAWN BY	DAT	DRWG DATE	03/31/84	APPV'D BY	DATE APPV'D	REV	C
DWG SCALE	NOTED	PRODUCT CODE	100	E0054			

REV	DATE	DESCRIPTION	INTL
A	11/22/91	REVISED CALCULATIONS	KMH
B	12/10/91	REVISED CALCULATIONS	KMH
C	4/2/02	WAS 1.438 +.01/-013	CRH

☐ DENOTES CRITICAL DIMENSION  
ALL DIES PROPERTY OF TUBELITE

**ATI**  
**Report #** B3772-116-45  
**Date** 10/20/2011  
**Simulator** Eric Barilko

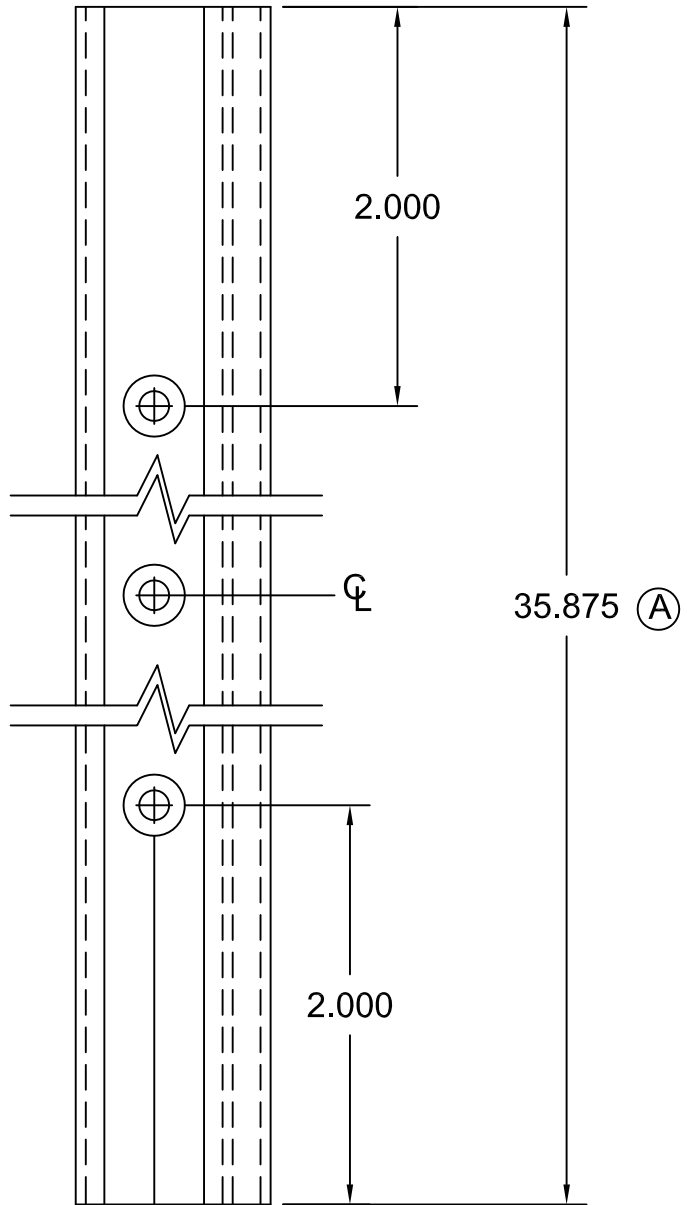

Operations:

1. Cut to length as required from E2059
2. Drill 3 holes with #25 Drl & Ctsk for S-064 (#6 FHCS)
3. Cut P-830 to length, Install, & Crimp ends
4. Cut P-914 to length, and install.
5. Paint ends as required
6. Ship with three (3) S064 Screws.

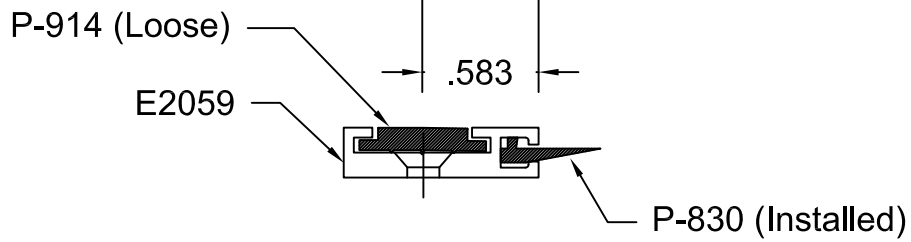

© 2006 TUBELITE INC. ALL RIGHTS RESERVED  
 ALL UNSPECIFIED RADII .015  
 \* INDICATES .031 RADIUS  
 □ DENOTES CRITICAL DIMENSION

**TUBELITE®**  
 DEPENDABLE  
 LEADERS IN ECO-EFFICIENT STOREFRONT,  
 CURTAINWALL AND ENTRANCE SYSTEMS

3056 WALKER RIDGE NW, SUITE G  
 WALKER, MICHIGAN 49544

REV	DATE	DESCRIPTION	INTL
	7/29/83	Released Part per ED 128	PJ
A	05/17/90	ED #1222 Dim was 34.875	KMH
B	8/24/01	Redrawn for CAD	DMT
C	06/19/03	OUTSOURCE - ADD S064 SCREWS	SRD

Door Seal to use with  
 E2058 Threshold

DRAWN BY PJ	DRWG DATE 05/09/83	APPV,D BY	DATE APPV'D
DRWG SCALE Full	PRODUCT CODE 380	P1275	
			REV C

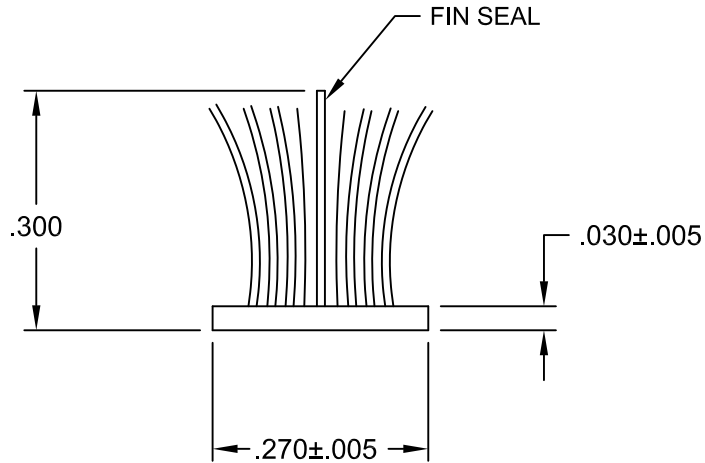

Actual Size

**ATI**

**Report #** B3772-116-45

**Date** 10/20/2011

**Simulator** Eric Bakula

© 2006 TUBELITE INC. ALL RIGHTS RESERVED

ALL UNSPECIFIED RADII .015

\* INDICATES .031 RADIUS

DENOTES CRITICAL DIMENSION

**TUBELITE®**  
**DEPENDABLE**  
 LEADERS IN ECO-EFFICIENT STOREFRONT,  
 CURTAINWALL AND ENTRANCE SYSTEMS

3056 WALKER RIDGE NW, SUITE G  
 WALKER, MICHIGAN 49544

REV	DATE	DESCRIPTION	INTL
A	03/08/83	Release Part per ED 109	
B	05/29/02	Redrawn for CAD	DMT

<p><b>Poly Bond Fin-Seal Weathering</b>                  use with Door Stop E1377</p>			
DRAWN BY	Don H	DRWG DATE	06/03/83
APPV,D BY		DATE APPV'D	
DRWG SCALE	Noted	PRODUCT CODE	380
<p><b>P1098A</b></p>			<p><b>B</b></p>



Actual Size

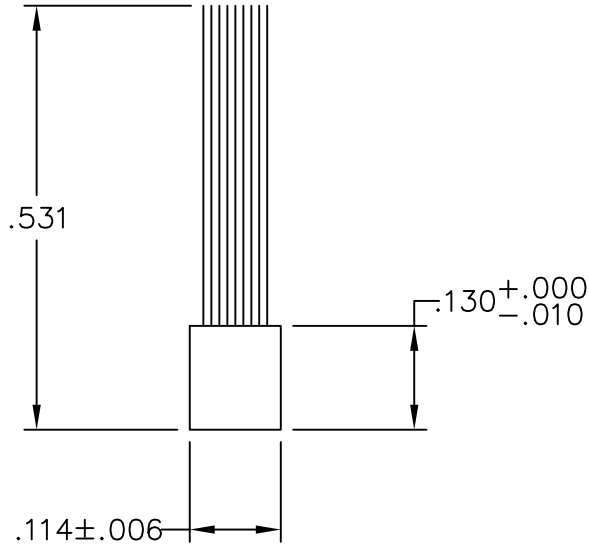

Four Times Size

Purchased Part

Schlege Pile Weathering  
Part Number 364-1006-5101

<b>ATI</b>	
<b>Report #</b>	<u>B3772-116-45</u>
<b>Date</b>	<u>10/20/2011</u>
<b>Simulator</b>	<u>Eric Barilac</u>

© 2006 TUBELITE INC. ALL RIGHTS RESERVED

ALL UNSPECIFIED RADII .015

\* INDICATES .031 RADIUS

□ DENOTES CRITICAL DIMENSION

**TUBELITE®**  
DEPENDABLE  
LEADERS IN ECO-EFFICIENT STOREFRONT,  
CURTAINWALL AND ENTRANCE SYSTEMS

3056 WALKER RIDGE NW, SUITE G  
WALKER, MICHIGAN 49544

REV	DATE	DESCRIPTION	INTL
A	05/03/02	Redrawn for CAD	DMT

Pile Weathering to use with E1195 and E1152			
DRAWN BY PJ	DRWG DATE 10/03/75	APPV,D BY	DATE APPV'D
DRWG SCALE Noted	PRODUCT CODE 110	P938	
			REV <b>A</b>



**ATI**  
**Report #** B3772-116-45  
**Date** 10/20/2011  
**Simulator** Eric Barilac

  
**ACTUAL SIZE**

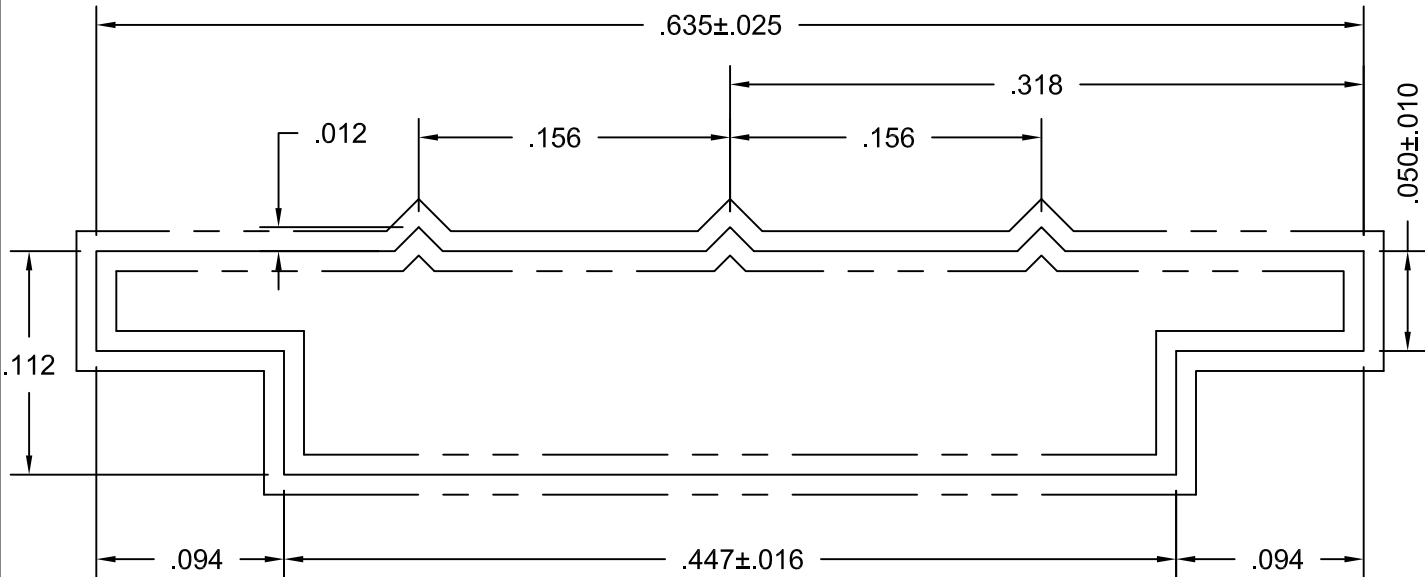

Ten Times Size

**NOTE: Part to receive Silicone Bath after Extruding**

**Purchased Part**  
**Avon Rubber**  
**90 Durometer**  
**250' Rolls**

© 2006 TUBELITE INC. ALL RIGHTS RESERVED  
 ALL UNSPECIFIED RADII .015  
 \* INDICATES .031 RADIUS  
 □ DENOTES CRITICAL DIMENSION



3056 WALKER RIDGE NW, SUITE G  
 WALKER, MICHIGAN 49544

REV	DATE	DESCRIPTION	INTL
A	01/19/96	Redrawn for AutoCAD	DMT

<b>EPDM Rubber Glazing</b> Use with M1061, M1063, M1202			
DRAWN BY	KMH	DRWG DATE	01/19/96
APPV,D BY		DATE APPV'D	
DRWG SCALE	Noted	PRODUCT CODE	380
<b>P914</b>			<b>A</b>

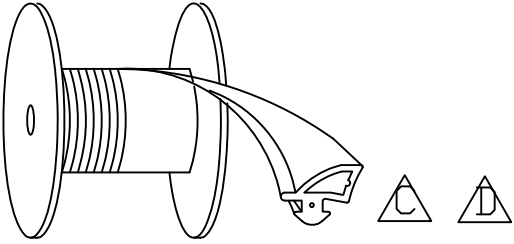

**ATI**

**Report #** B3772-116-45

**Date** 10/20/2011

**Simulator** Eric Baribe

Material must UNREEL like this...

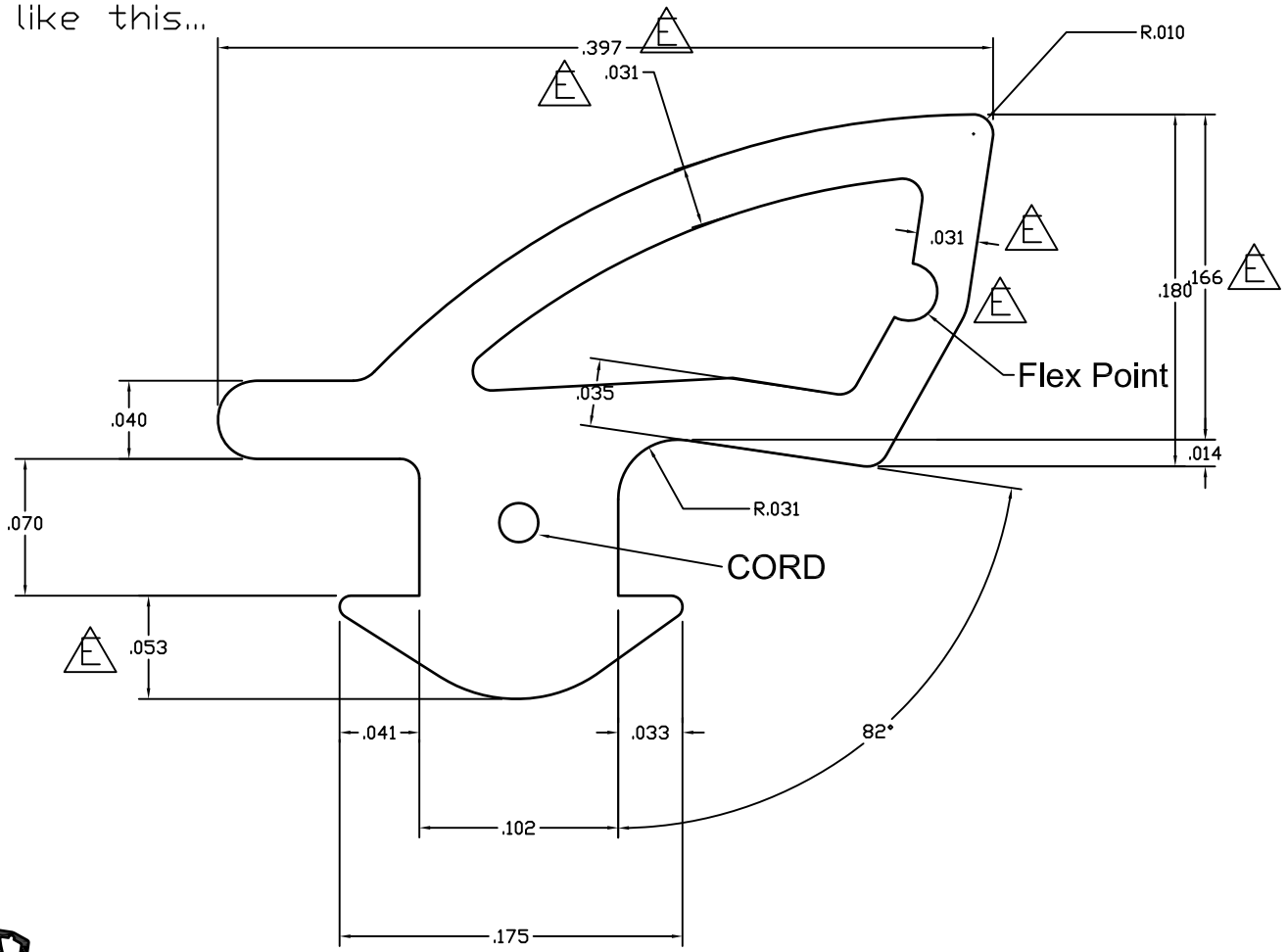

ACTUAL SIZE

MATERIAL: EPDM 60 DUROMETER WITH CORD

©2006 TUBELITE INC. ALL RIGHTS RESERVED  
 ALL UNSPECIFIED RADII .015  
 \* INDICATES .031 RADIUS  
 □ DENDOTES CRITICAL DIMENSION



3056 WALKER RIDGE NW, SUITE G  
 WALKER, MICHIGAN 49544

REV	DATE	DESCRIPTION	INTL
A	08/20/07	MODIFIED DART: .070 WAS .060 AND .051 WAS .061 ADDED CORD	NIK
B	10/16/08	ADDED MANUFACTURER'S TOLERANCES FOR REFERENCE	SRD
C	10/22/10	Modified gasket position of how the reel should roll	TT
D	12/16/10	Modified gasket position of how the reel should roll	TT
E	02/15/11	Rev flex pt, thickness was .032, .180 was .188	TT

1/4"-1" DOOR GLAZING GASKET 500' ROLLS			
DRAWN BY NIK	DRWG DATE 4-17-07	APPV.D BY	DATE APPV'D
DRWG SCALE 10X	PRODUCT CODE 100	P0017	REV E