

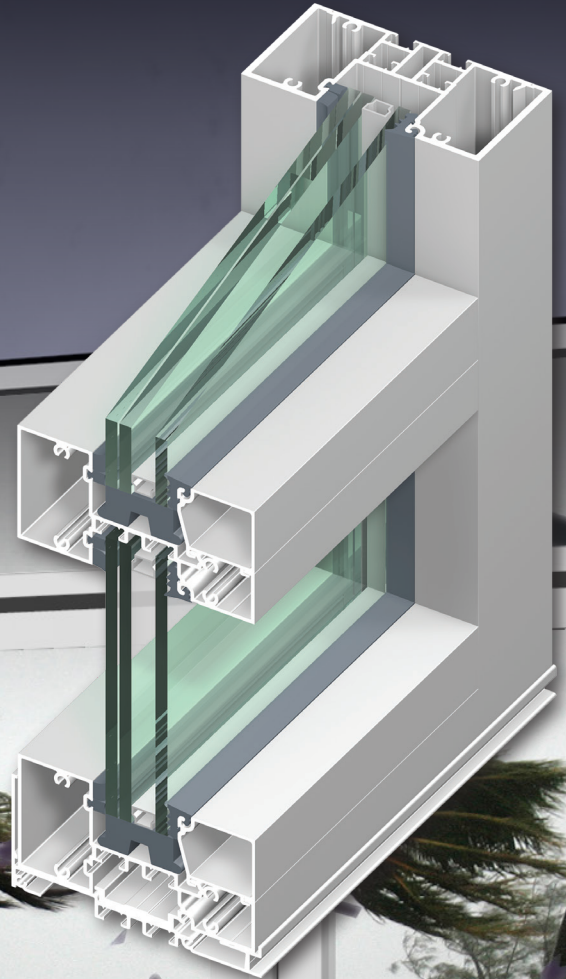

E34000-Wet Storefront

ForceFront® Storm E34000 Storefront is a 2-1/2" x 5" flush glazed system for use on low-rise single span applications in hurricane impact areas. The system meets the requirements of Florida Building Code High Velocity Hurricane (HVHZ) Zone 4 – large missile impact and cycling [ASTM E1886-05 / 1996-09, TAS 201-94 and TAS 203-94]. Features include screw spline frame construction, exterior center set glazing, heavy duty vertical mullion, and accepts 1-5/16" insulated laminated glass installed using wet-glazed or dry-glazed method.

ForceFront Storm Curtainwall (FFS-CW) and Medium and Monumental Entrance Doors compliment the storefront, providing a complete hurricane resistant system that's easy to fabricate and install.



ForceFront® Storm
Curtainwall

ForceFront® Storm
Medium Stile Entrance

ALSO
USED
WITH

TUBELITE®
DEPENDABLE

LEADERS IN ECO-EFFICIENT STOREFRONT,
CURTAINWALL AND ENTRANCE SYSTEMS



Tubelite ForceFront® Storm E34000 Storefront

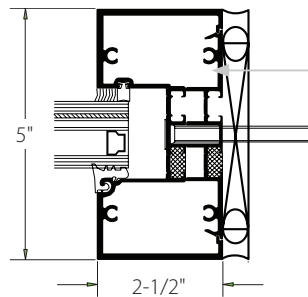
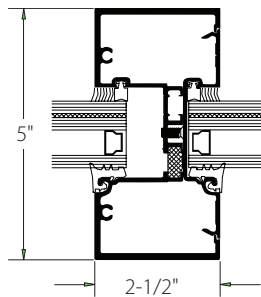
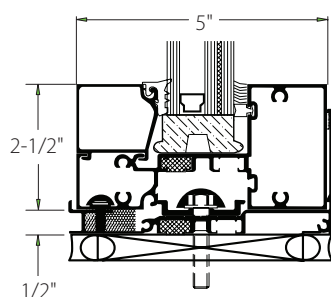
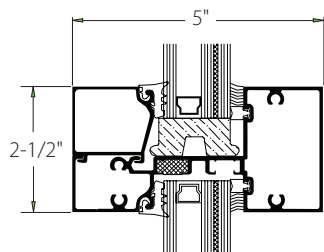
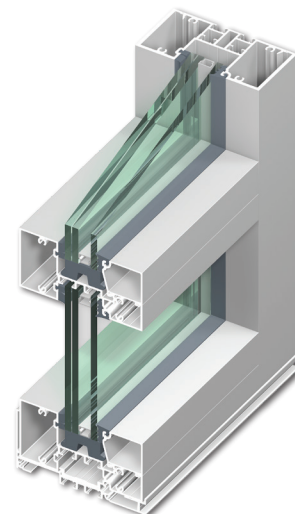

System Features:

- Standard 2-1/2" (63.5mm) sight-line on verticals and horizontals
- 5" (127mm) system depth
- EPDM wedge type gaskets for 1" glass or panel thickness
- Glass centered in the system depth

Optional Features:

- Screw-spline or shear block connections
- Steel reinforcing if required
- Easily integrates with Medium Stile or Monumental Stile Impact Resistant Doors & Curtainwall
- A wide variety of standard anodized and painted colors are available to complement any project with warranted protection, as well as street appeal.

ForceFront® Storm Storefront E34000 2-1/2" x 5"		
Glass Makeup:	1-5/16" Insulated Lami: 1/4" (ext) - 1/2" air space - 9/16" lami (int) - options in table below	
Approvals:	Florida Product Approval including HVHZ and Texas Department of Insurance	
Options:	Thermal or non thermal frames, single span, exterior center set wet and dry glazing, heavy duty vertical mullion, and ForceFront Storm Entrance Doors (under separate approval)	
Hurricane Testing:	Large Missile (D) and Small Missile (A)	ASTM E1886-05 / 1996-09, TAS 201-94, and TAS 203-94
Air Infiltration:	0.06 cfm/ft2 @ 6.24 psf	ASTM E283-04 and TAS 202-94
Water Resistance:	15 psf (static)	ASTM E331-00, TAS 202-94
U-Factor**:	0.37 (thermal option)	NFRC 100, glazed wall configuration
CRF (frame):	59 (thermal option)	AAMA 1503
STC:	36 (.090 Sentry lami)	ASTM E90-09
OITC:	32 (.090 Sentry lami)	ASTM E1332-10a
Structural:	up to +70 / -68 psf	ASTM E330-02 and TAS 202-94

** U-Factor per NFRC 100: COG = 0.24 with warm edge spacer, 1-3/4" x 4-1/2" non-thermal frame. Refer to the U-Factor table at: <https://www.tubeliteinc.com/products/storefront/34000-forcefront-impact-resistant-framing/> for other glass makeups and configurations.

ForceFront® Storm Storefront E34000 Product Specifications

System (2-1/2" x 5")	Glass Size (max)	Frame Height (max)	Design Pressure (psf)	Missile Type	Interlayer Makeups Tested*	Texas Department of Insurance (TDI)	Florida Product Approval (FPA)	Florida Building Code HVHZ
E34000 Non Thermal (wet glazed)	48" x 120"	123-3/4"	+ 70 / - 68	Large (D)	1/4" HS - .090 Sentry Glas - 1/4" HS 1/4" HS - .077 Saflex CP - 1/4" HS	CWFS-44	FL17192.1	Yes

The above table is for reference only. Refer to FPA or TDI installation instructions for approved frame sizes and configurations, design pressures, mullion types, reinforcement requirements, glass makeups, anchorage requirements, etc.

DISCLAIMER: Tubelite takes no responsibility for product selection or application, including but not limited to, compliance with building codes, safety codes, laws, merchantability or fitness for a particular purpose; and further disclaims all liability for the use, in whole or in part, of this Product Brochure in preparation of project specifications and/or other documents. Product Brochures are subject to change at any time, without notice, and at Tubelite's sole discretion. © 2016 Tubelite Inc.

06.29.20

TUBELITE®

DEPENDABLE

LEADERS IN ECO-EFFICIENT STOREFRONT, CURTAINWALL AND ENTRANCE SYSTEMS

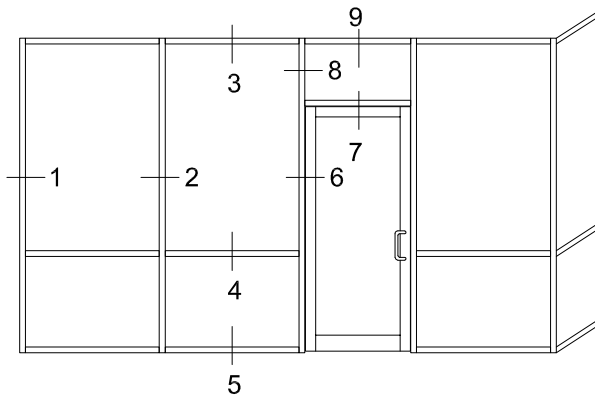

Tubelite reserves the right to change system configuration without prior notice when deemed necessary for product improvements.

Laws and building & safety codes governing the design and use of glazed entrance, window and curtain wall systems vary widely. Tubelite does not control the selection of product configurations, operating hardware or glazing materials, and assumes no responsibility thereof.

WET GLAZED
Standard Details
 1/4 scale

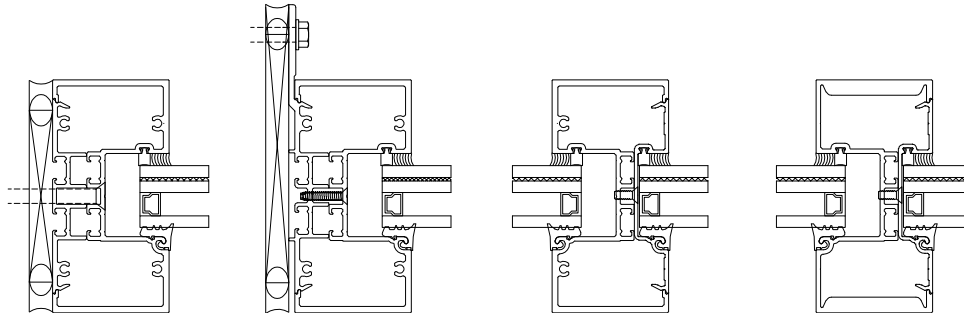

1 1A 2 2A

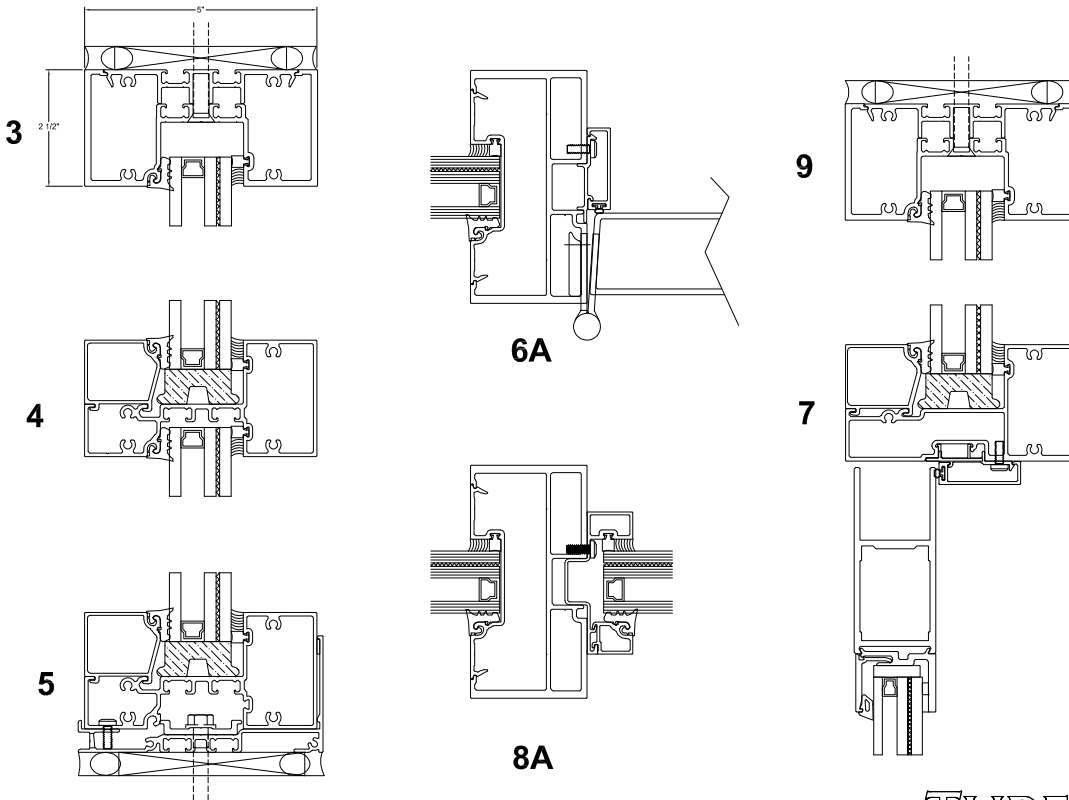

TUBELITE®
 DEPENDABLE
 LEADERS IN ECO-EFFICIENT STOREFRONT,
 CURTAINWALL AND ENTRANCE SYSTEMS

January 2020

For specific product applications, contact your Tubelite representative.
 Details on this page represent standard details found on our website.
 For more options, visit our website at www.tubeliteinc.com/e34000-forcefront-impact-resistant-framing/



E34000-Dry Storefront

ForceFront® Storm E34000 Storefront is a 2-1/2" x 5" flush glazed system for use on low-rise single span applications in hurricane impact areas. The system meets the requirements of Florida Building Code High Velocity Hurricane (HVHZ) Zone 4 – large missile impact and cycling [ASTM E1886-05 / 1996-09, TAS 201-94 and TAS 203-94]. Features include screw spline frame construction, exterior center set glazing, heavy duty vertical mullion, and accepts 1-5/16" insulated laminated glass installed using wet-glazed or dry-glazed method.

ForceFront Storm Curtainwall (FFS-CW) and Medium and Monumental Entrance Doors compliment the storefront, providing a complete hurricane resistant system that's easy to fabricate and install.

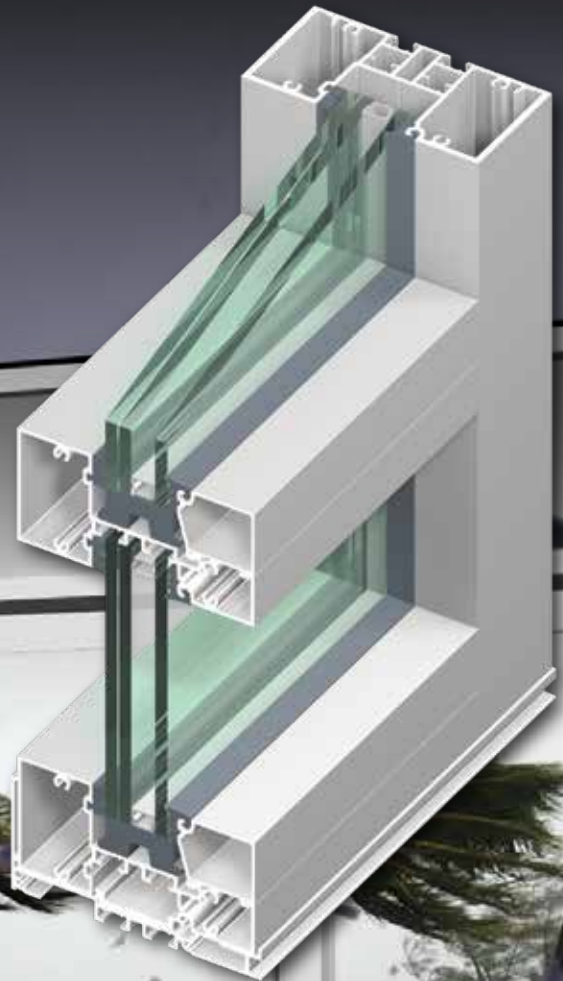

**ForceFront Storm
Curtainwall**

**ALSO
USED
WITH**

**ForceFront Storm
Medium Stile Entrance**

TUBELITE®
DEPENDABLE

LEADERS IN ECO-EFFICIENT STOREFRONT,
CURTAINWALL AND ENTRANCE SYSTEMS



Tubelite ForceFront® Storm E34000 Storefront

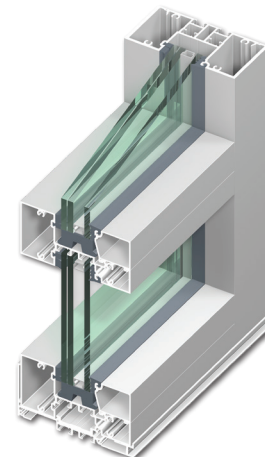
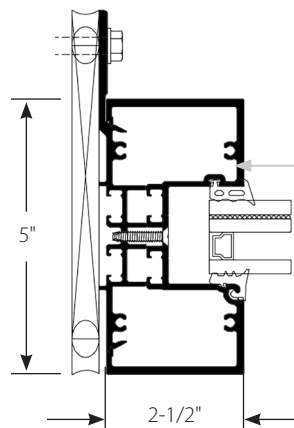
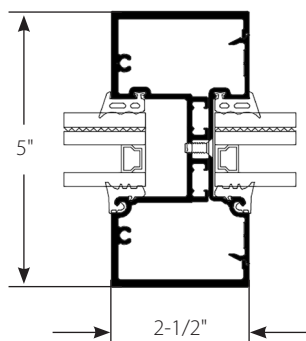
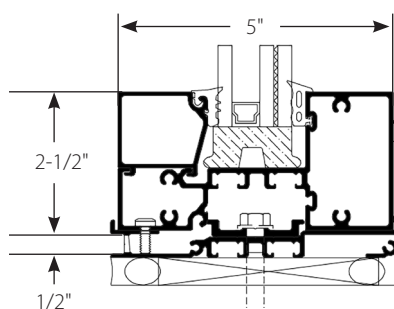
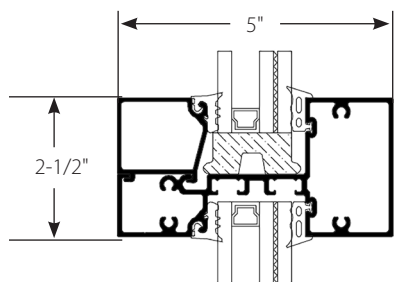

Screw Spline Frame Construction

System Features:

- Standard 2-1/2" (63.5mm) sight-line on verticals and horizontals
- 5" (127mm) system depth
- EPDM wedge type gaskets for 1" glass or panel thickness
- Glass centered in the system depth

Optional Features:

- Screw-spline or shear block connections
- Steel reinforcing if required
- Easily integrates with Medium Stile or Monumental Stile Impact Resistant Doors & Curtainwall
- A wide variety of standard anodized and painted colors are available to complement any project with warranted protection, as well as street appeal.

ForceFront® Storm Storefront E34000 2-1/2" x 5"		
Glass Makeup:	1-5/16" Insulated Lami: 1/4" (ext) - 1/2" air space - 9/16" lami (int) - options in table below	
Approvals:	Florida Product Approval including HVHZ and Texas Department of Insurance	
Options:	Thermal or non thermal frames, single span, exterior center set wet and dry glazing, heavy duty vertical mullion, and ForceFront Storm Entrance Doors (under separate approval)	
Hurricane Testing:	Large Missile (D) and Small Missile (A)	ASTM E1886-05 / 1996-09, TAS 201-94, and TAS 203-94
Air Infiltration:	0.06 cfm/ft2 @ 6.24 psf	ASTM E283-04 and TAS 202-94
Water Resistance:	15 psf (static)	ASTM E331-00, TAS 202-94
U-Factor**:	0.37 (thermal option)	NFRC 100, glazed wall configuration
CRF (frame):	59 (thermal option)	AAMA 1503
STC:	36 (.090 Sentry lami)	ASTM E90-09
OITC:	32 (.090 Sentry lami)	ASTM E1332-10a
Structural:	up to +70 / -68 psf	ASTM E330-02 and TAS 202-94

** U-Factor per NFRC 100: COG = 0.24 with warm edge spacer, 1-3/4" x 4-1/2" non-thermal frame. Refer to the U-Factor table at: <https://www.tubeliteinc.com/products/storefront/34000-forcefront-impact-resistant-framing/> for other glass makeups and configurations.

ForceFront® Storm Storefront E34000 Product Specifications

System (2-1/2" x 5")	Glass Size (max)	Frame Height (max)	Design Pressure (psf)	Missile Type	Interlayer Makeups Tested*	Texas Department of Insurance (TDI)	Florida Product Approval (FPA)	Florida Building Code HVHZ
E34000 Non Thermal (dry glazed)	48" x 120"	123-3/4"	+ 70 / - 61	Large (D)	1/4" HS - .090 Sentry Glas - 1/4" HS	CWFS-44	FL17192.1	Yes
E34000 Non Thermal (dry glazed)	48" x 96"	99-3/4"	+ 50 / - 50	Large (D) Small (A)	1/4" HS - .090 Butacite PVB - 1/4" HS	CWFS-44	FL17192.1	Yes

The above table is for reference only. Refer to FPA or TDI installation instructions for approved frame sizes and configurations, design pressures, mullion types, reinforcement requirements, glass makeups, anchorage requirements, etc.

DISCLAIMER: Tubelite takes no responsibility for product selection or application, including but not limited to, compliance with building codes, safety codes, laws, merchantability or fitness for a particular purpose; and further disclaims all liability for the use, in whole or in part, of this Product Brochure in preparation of project specifications and/or other documents. Product Brochures are subject to change at any time, without notice, and at Tubelite's sole discretion. © 2016 Tubelite Inc.

06.29.20



LEADERS IN ECO-EFFICIENT STOREFRONT, CURTAINWALL AND ENTRANCE SYSTEMS

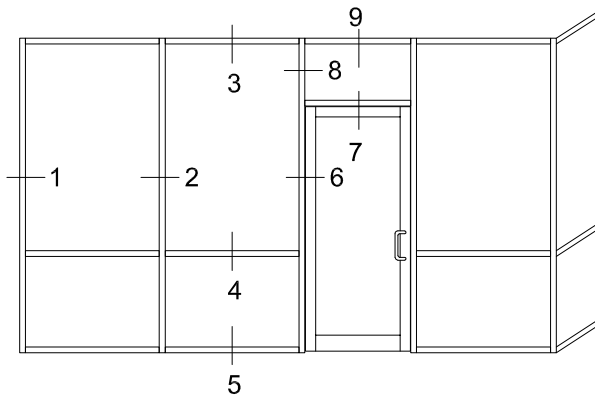

Tubelite reserves the right to change system configuration without prior notice when deemed necessary for product improvements.

Laws and building & safety codes governing the design and use of glazed entrance, window and curtain wall systems vary widely. Tubelite does not control the selection of product configurations, operating hardware or glazing materials, and assumes no responsibility thereof.

DRY GLAZED
Standard Details
 1/4 scale

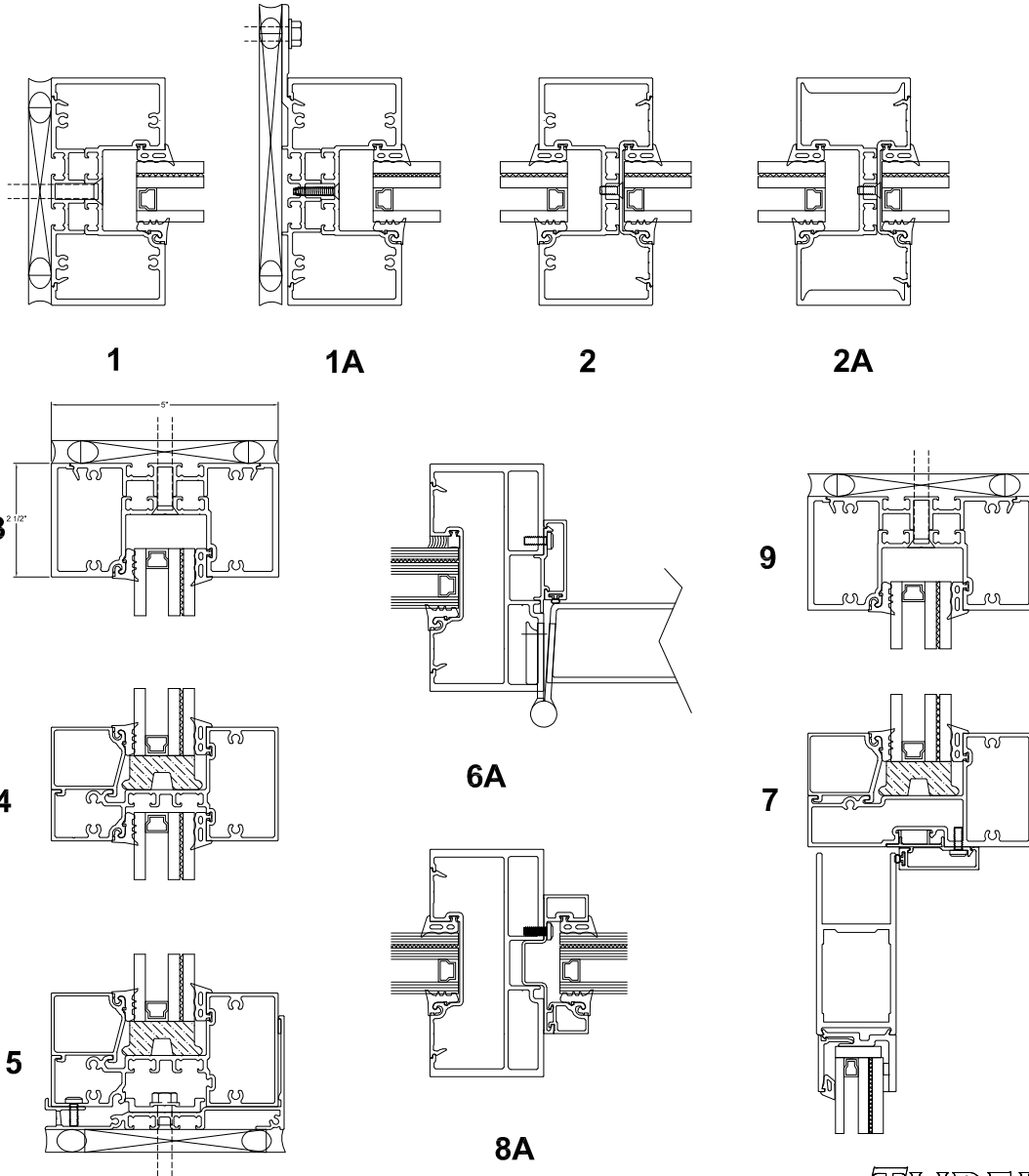

TUBELITE®
 DEPENDABLE
 LEADERS IN ECO-EFFICIENT STOREFRONT,
 CURTAINWALL AND ENTRANCE SYSTEMS

January 2020

For specific product applications, contact your Tubelite representative.
 Details on this page represent standard details found on our website.
 For more options, visit our website at www.tubeliteinc.com/e34000-forcefront-impact-resistant-framing/