

TYPICAL ELEVATION

400TU ULTRA THERMAL CURTAIN WALL
 3 3/4" BACK MEMBER, DUAL GLAZE, SCREW SPLINE
 ALUMINUM PRESSURE PLATE

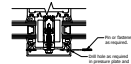

FACE COVER PINNING

FOR HIGH THERMAL PERFORMANCE
 PRESSURE PLATES SEE THERMAL
 PRESSURE PLATE PERIMETER SHEET.
 PERIMETER SHEET INCLUDES POLYAMIDE
 PRESSURE PLATE.

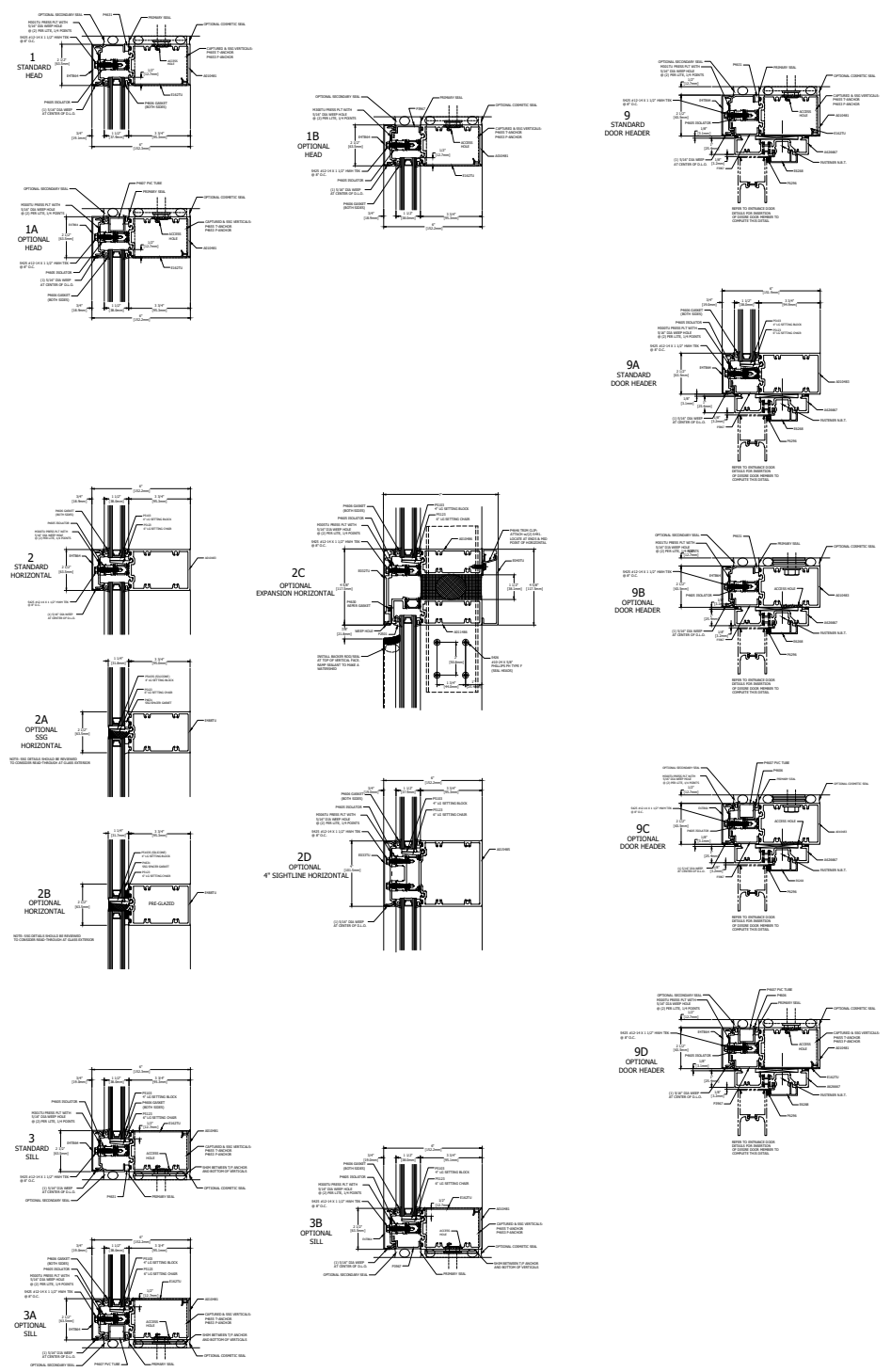

VERTICAL DETAILS

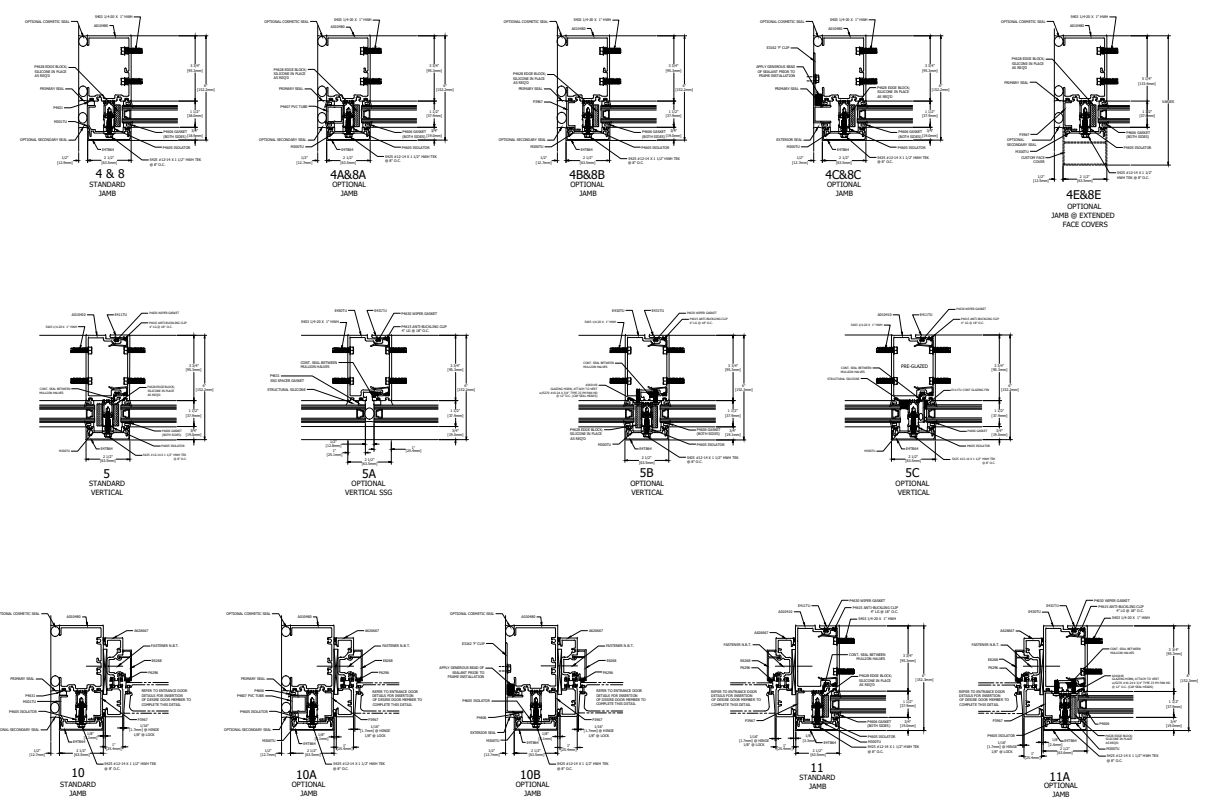

SPLICE AND ANCHOR
 DETAILS

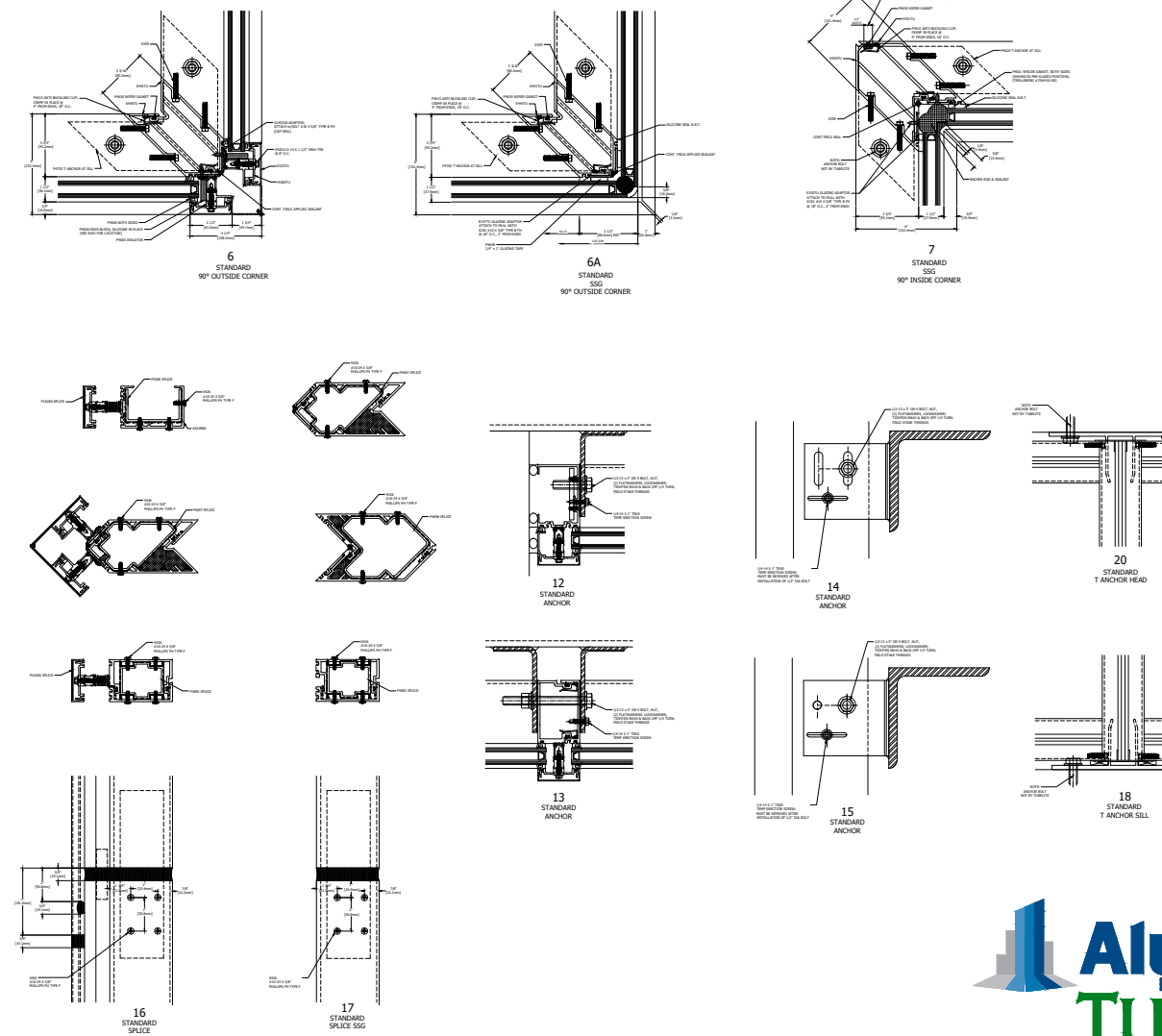

HORIZONTAL DETAILS

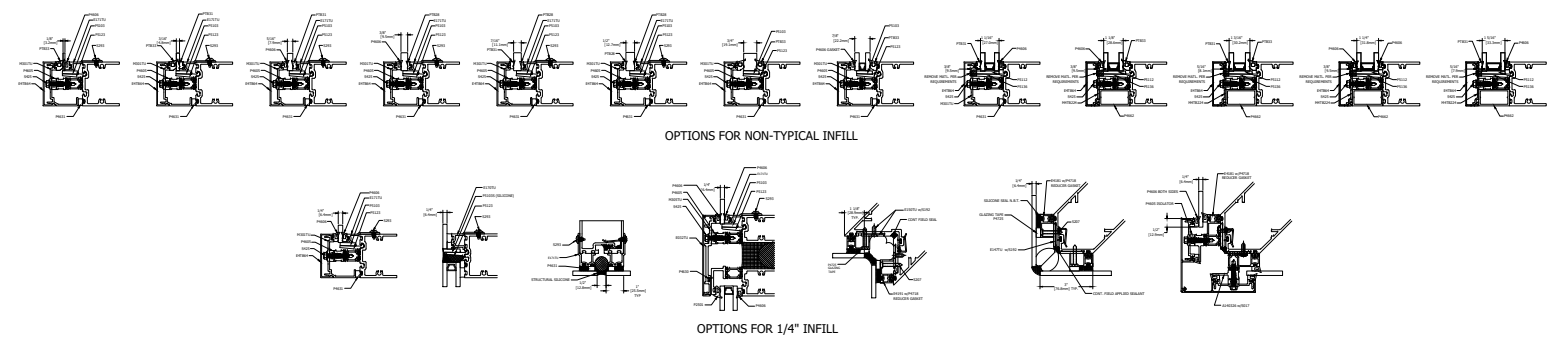

GLAZING INFILL OPTIONS

NOTE: TYPICAL GLASS BITE 1/2" FROM DLO
 UNLESS NOTED AT DETAIL.
 GLASS SHOWN DOES NOT NECESSARILY REPRESENT FINAL CONFIGURATION.
 CONSULT GLASS MANUFACTURER FOR SPECIFIC GLASS MAKE UP.