

TYPICAL ELEVATION

400TU ULTRA THERMAL CURTAIN WALL
5 1/4" BACK MEMBER, DUAL GLAZE, SHEAR CLIP
ALUMINUM PRESSURE PLATE



FACE COVER PINNING

FOR HIGH THERMAL PERFORMANCE
PRESSURE PLATES SEE THERMAL
PRESSURE PLATE PERIMETER SHEET.
PERIMETER SHEET INCLUDES POLYAMIDE
PRESSURE PLATE.

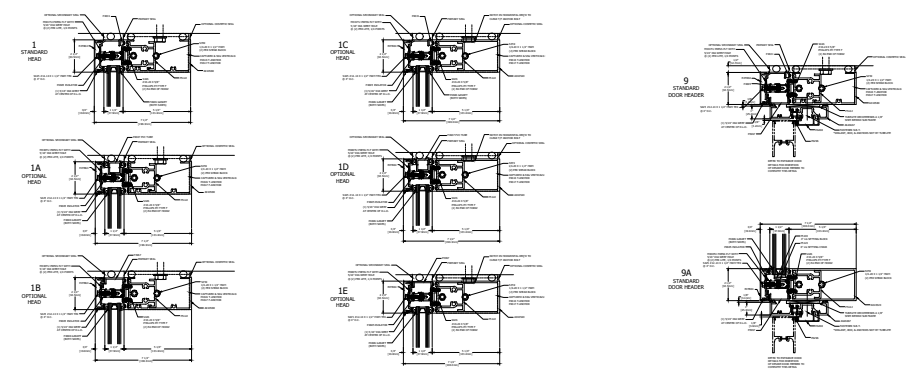

VERTICAL DETAILS

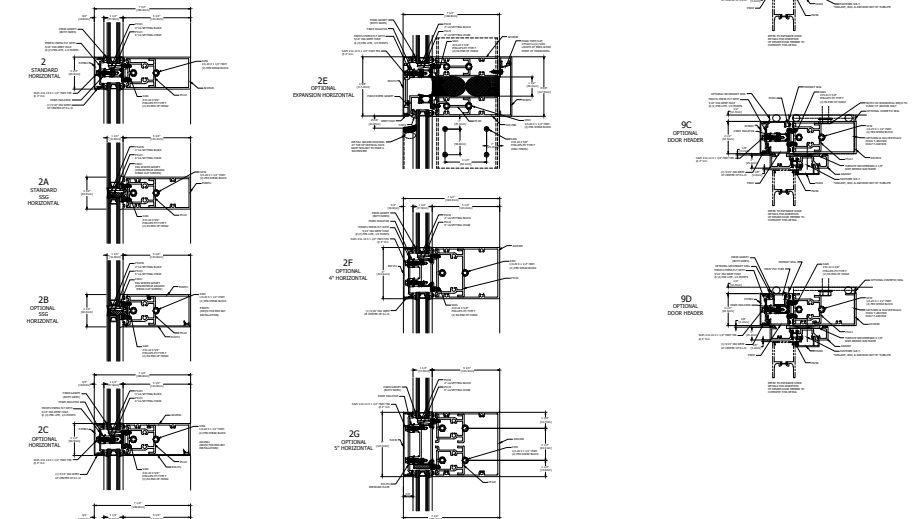
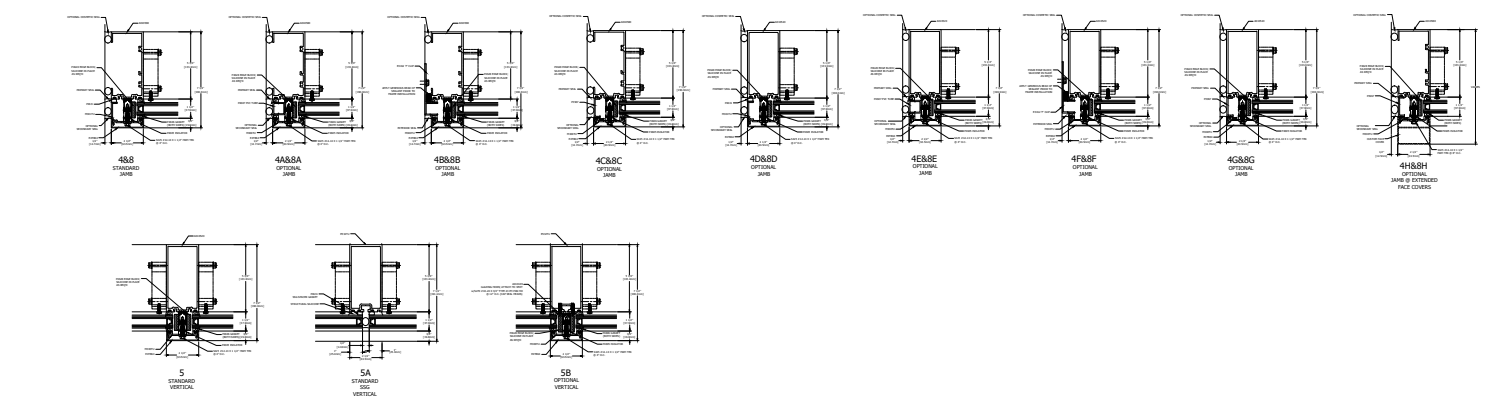

SPLICE AND ANCHOR DETAILS

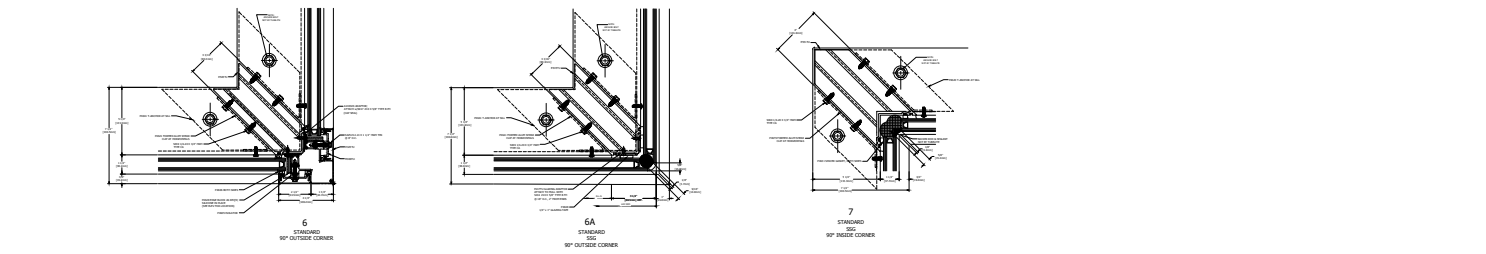
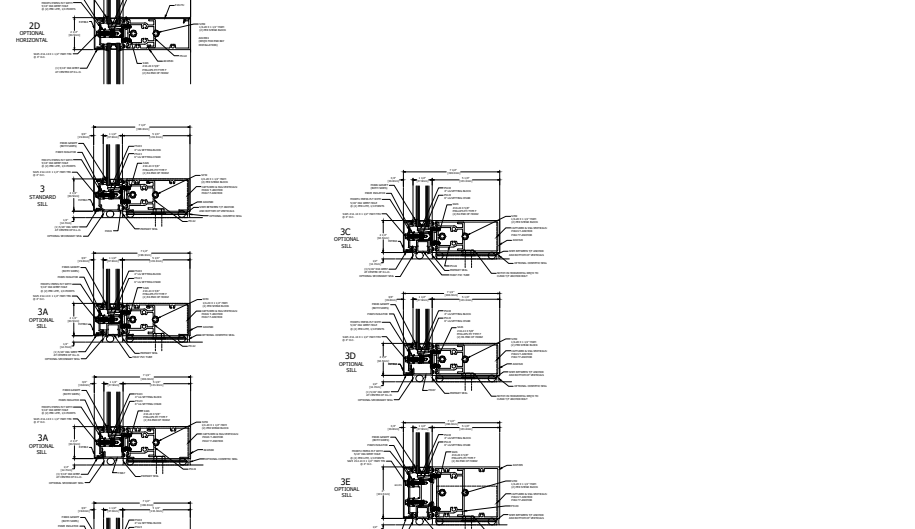
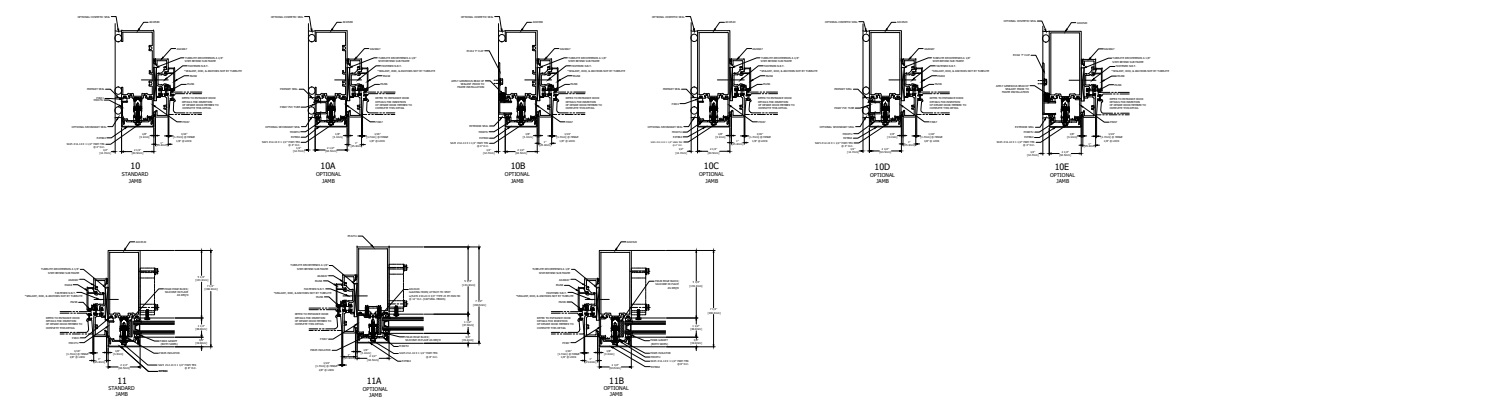

HORIZONTAL DETAILS

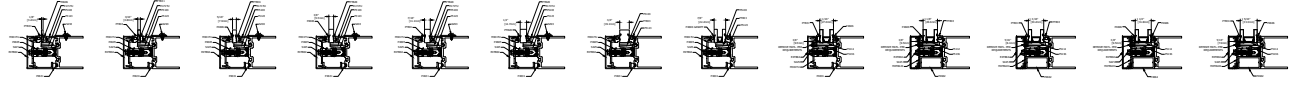
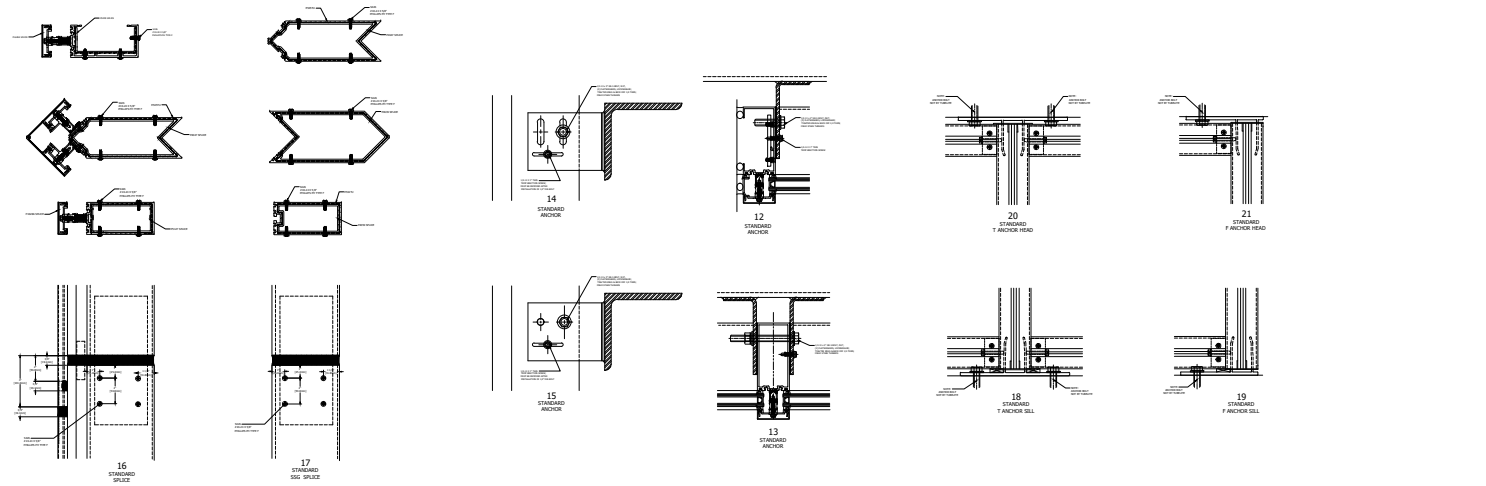

OPTIONS FOR NON-TYPICAL INFILL

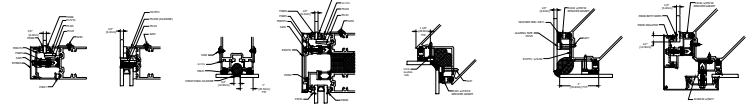

OPTIONS FOR 1/4" INFILL

GLAZING INFILL OPTIONS

NOTE: TYPICAL GLASS BITE 1/2" FROM DLO
UNLESS NOTED AT DETAIL.
GLASS SHOWN DOES NOT NECESSARILY REPRESENT FINAL CONFIGURATION.
CONSULT GLASS MANUFACTURER FOR SPECIFIC GLASS MAKE UP.