

TYPICAL ELEVATION

400TU ULTRA THERMAL CURTAIN WALL  
5 1/4" BACK MEMBER, DUAL GLAZE, SHEAR CLIP  
ALUMINUM PRESSURE PLATE

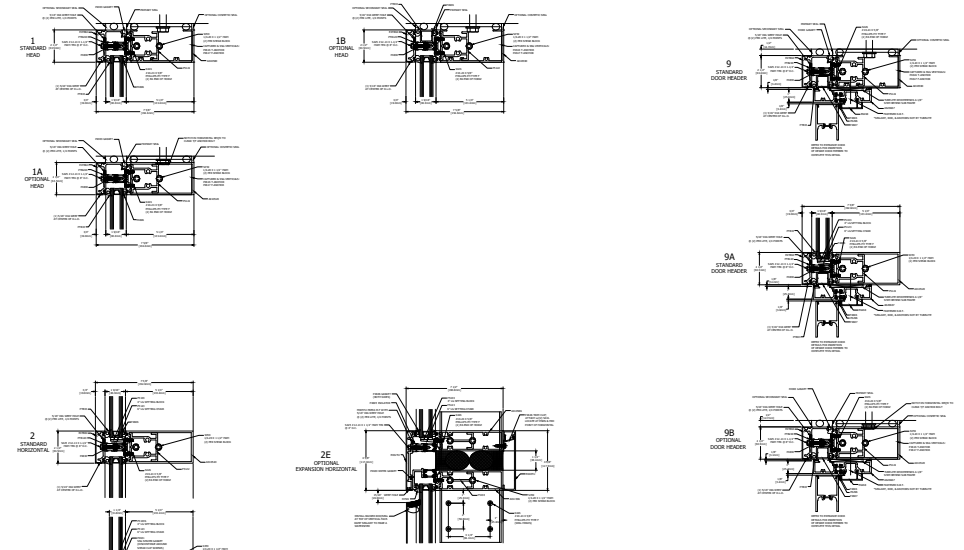

VERTICAL DETAILS

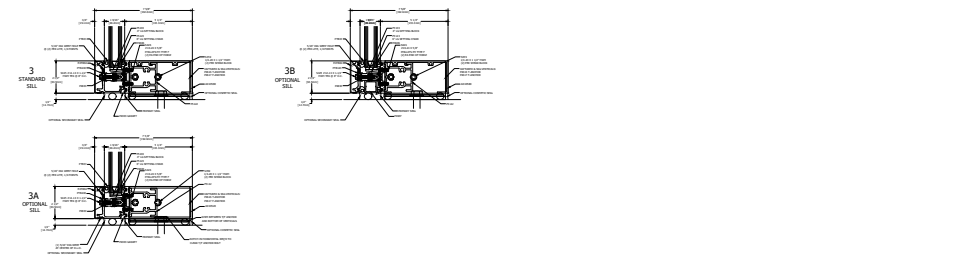
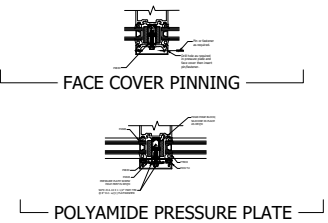
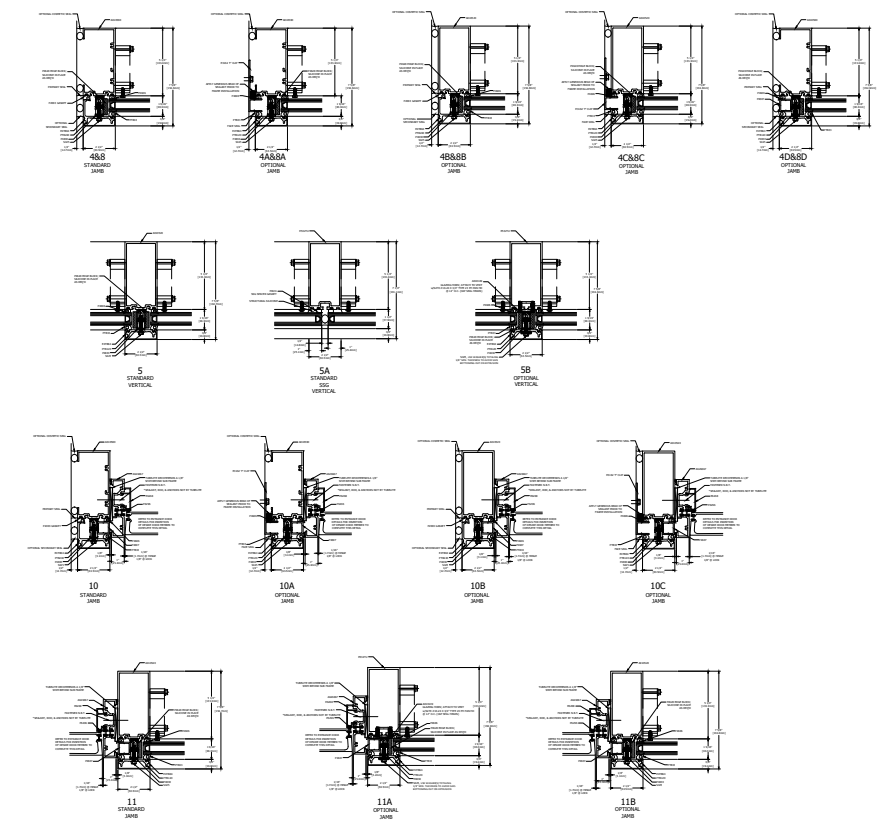

HORIZONTAL DETAILS

SPLICE AND ANCHOR DETAILS

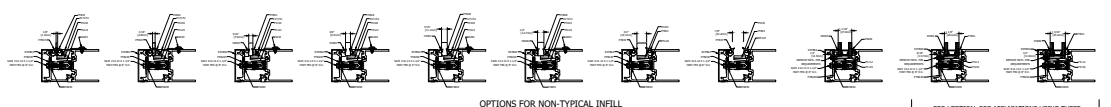
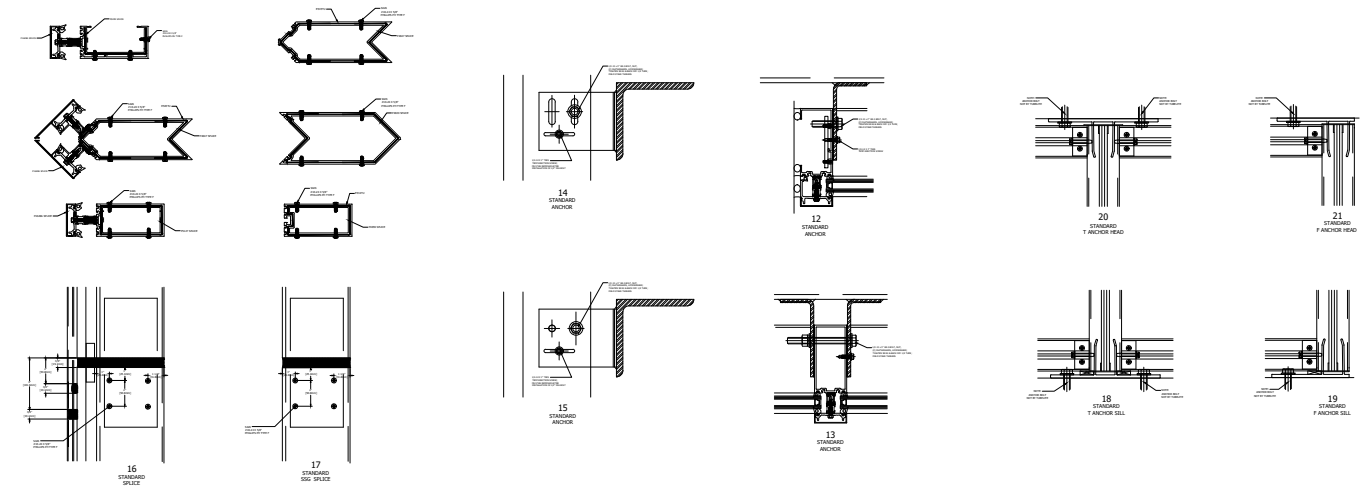

OPTIONS FOR NON-TYPICAL INFILL

FOR VERTICAL SSG APPLICATIONS USING THESE GLAZING OPTIONS A SPECIAL VERTICAL SSG HULLION MAY BE REQUIRED TO PROVIDE 1/4" SILICONE JOINT THICKNESS. CONSULT TUBELITE ENGINEERING.

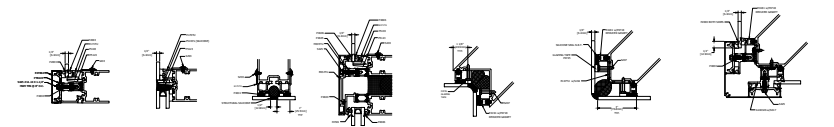

OPTIONS FOR 1/4" INFILL

GLAZING INFILL OPTIONS  
GLASS SHOWN DOES NOT NECESSARILY REPRESENT FINAL CONFIGURATION. CONSULT GLASS MANUFACTURER FOR SPECIFIC GLASS MAKE UP.

NOTE: TYPICAL GLASS BITE 1/2" FROM DLO UNLESS NOTED AT DETAIL.

USE OF SSG VERTICALS WITH THESE GLAZING OPTIONS REQUIRE 1/4" SILICONE JOINT THICKNESS FOR OPTIMUM STRUCTURAL SILICONE PERFORMANCE. CONSULT TUBELITE ENGINEERING FOR ANY CUSTOM CONFIGURATIONS REQUIRED.