

TYPICAL ELEVATION

400TU ULTRA THERMAL CURTAIN WALL
5 1/4" BACK MEMBER, TRIPLE GLAZE, SCREW SPLNE
ALUMINUM PRESSURE PLATE

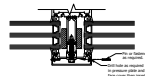

FACE COVER PINNING

FOR HIGH THERMAL PERFORMANCE
PRESSURE PLATES SEE THERMAL
PRESSURE PLATE PERIMETER SHEET.
PERIMETER SHEET INCLUDES POLYAMIDE
PRESSURE PLATE.

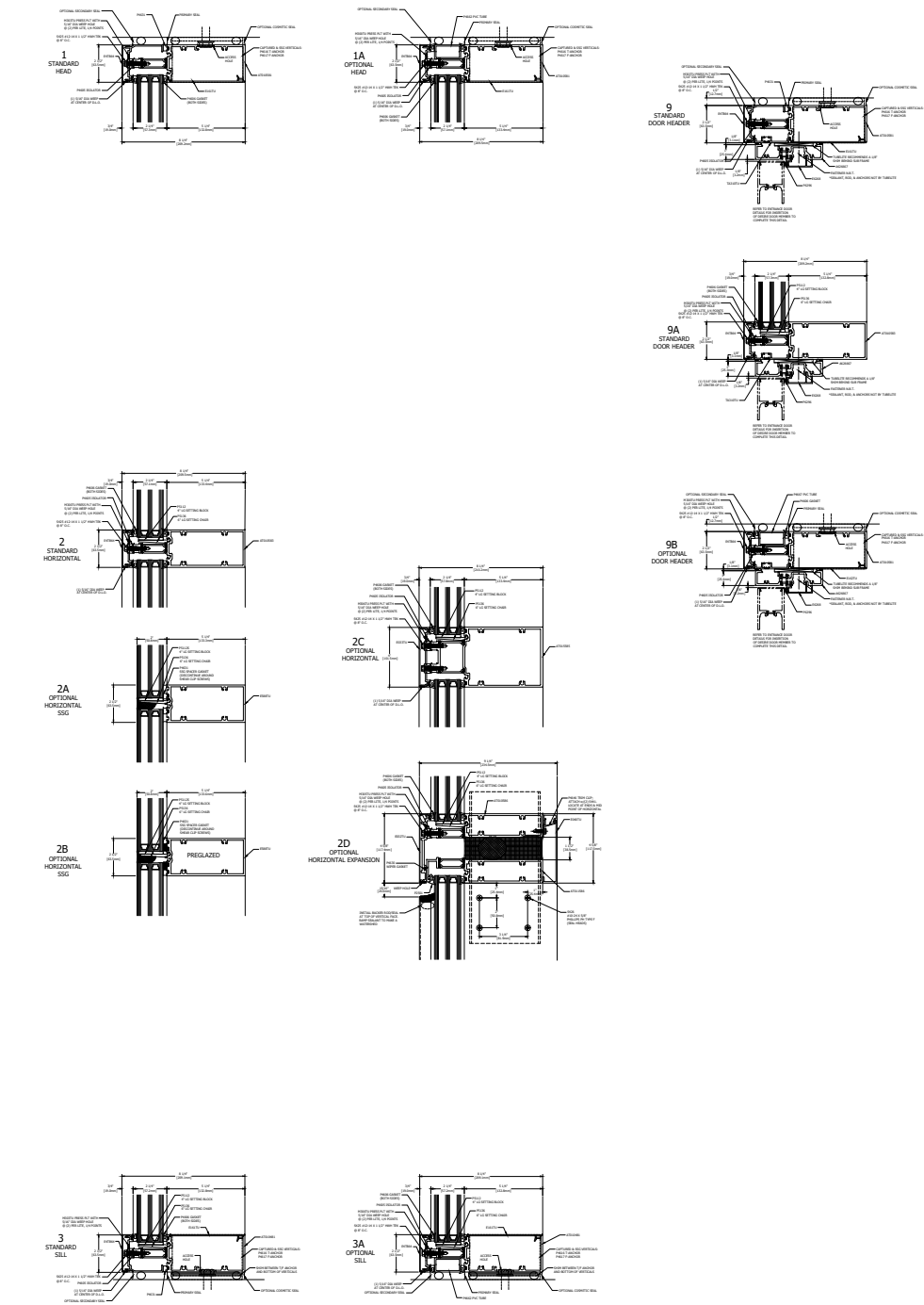

VERTICAL DETAILS

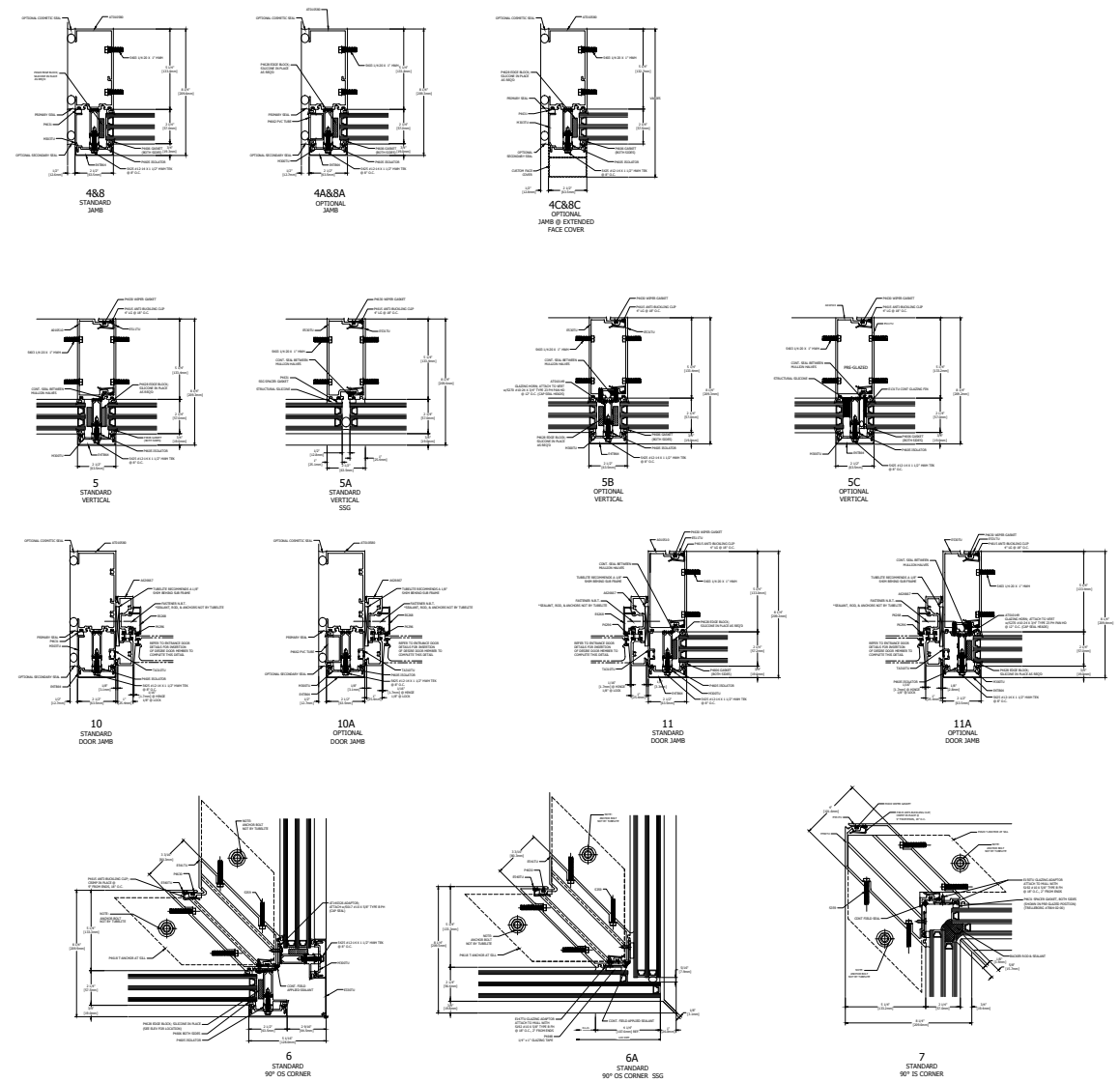

SPLICE AND ANCHOR DETAILS

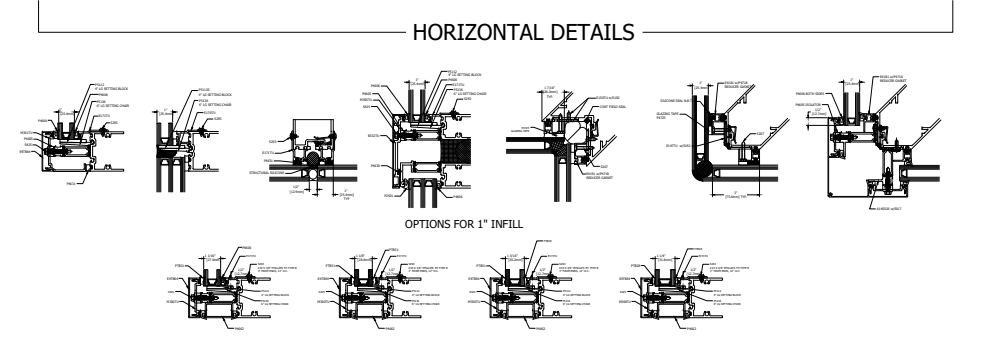

GLAZING INFILL OPTIONS

GLASS SHOWN DOES NOT NECESSARILY REPRESENT FINAL CONFIGURATION.
CONSULT GLASS MANUFACTURER FOR SPECIFIC GLASS MAKE UP.