

TYPICAL ELEVATION

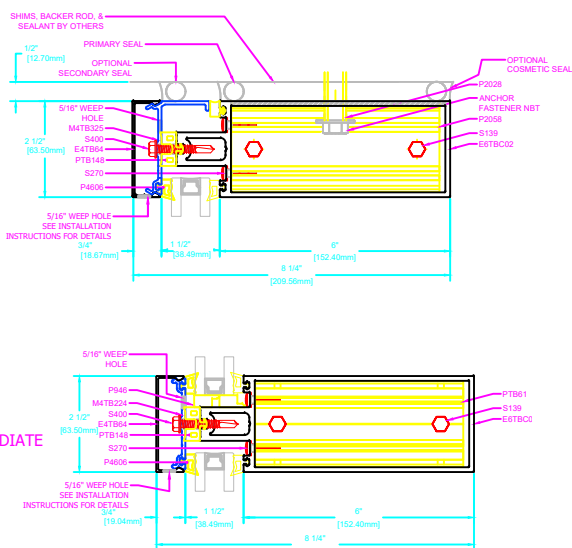

400T SERIES
 400T SERIES CURTAIN WALL
 PERIMETER SHEET
 8.25" SYSTEM DEPTH, 6" BACK MEMBER
 INTERSTORY HORIZONTAL EXPANSION, ALUMINUM PRESSURE

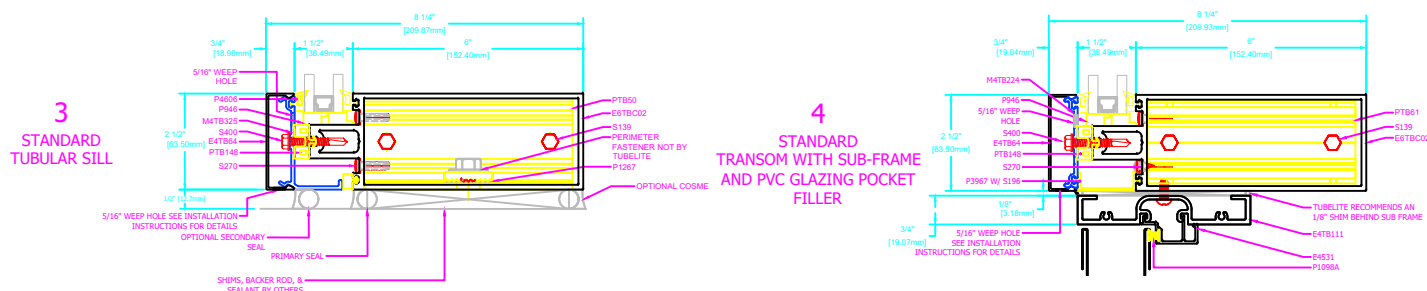

HORIZONTAL DETAILS

Standard Details
 1/5 scale

September 2022



For specific product applications, contact your representative.
www.alumicor.com **PAGE 1** www.tubeliteinc.com



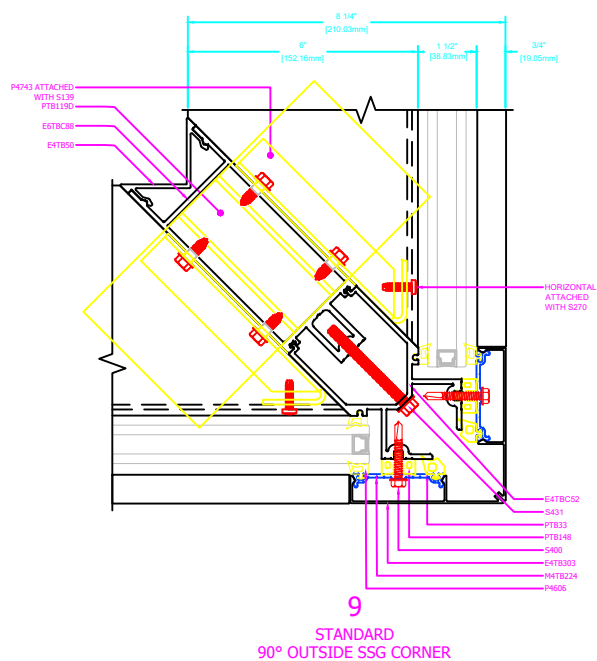
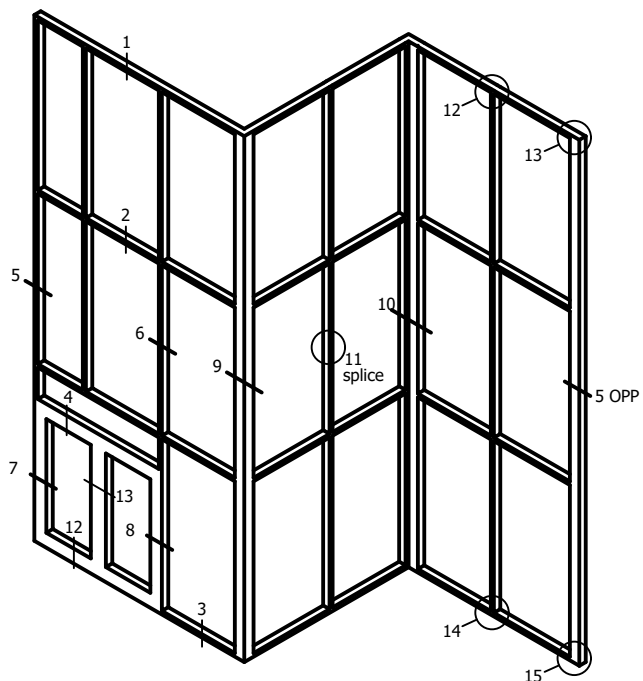

9 STANDARD 90° OUTSIDE SSG CORNER

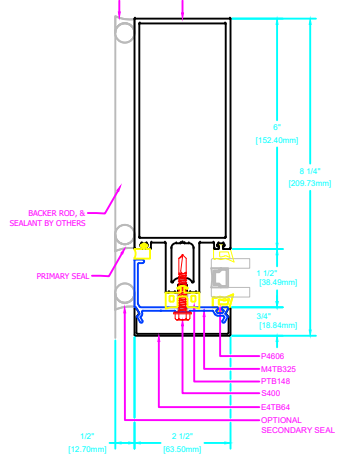

5 STANDARD TUBULAR JAMB

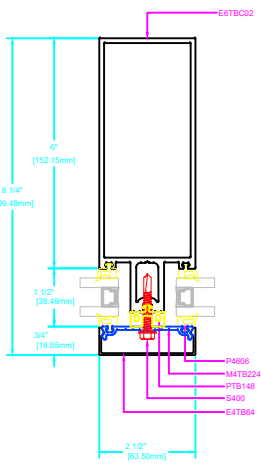

6 STANDARD TUBULAR MULLION

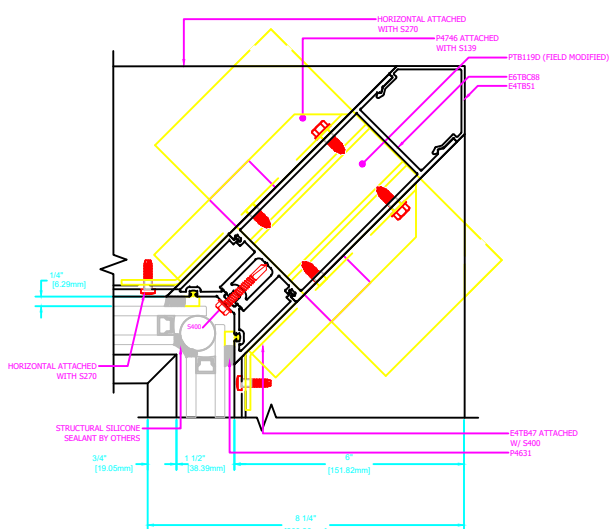

10 STANDARD 90° INSIDE SSG CORNER

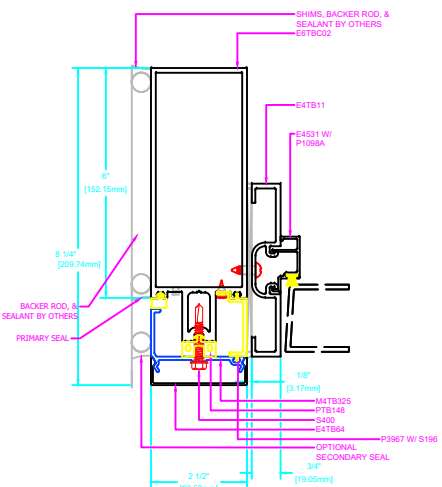

7 STANDARD DOOR JAMB AT PERIMETER PRESSURE PLATE W/ ALUMINUM POCKET CLOSER

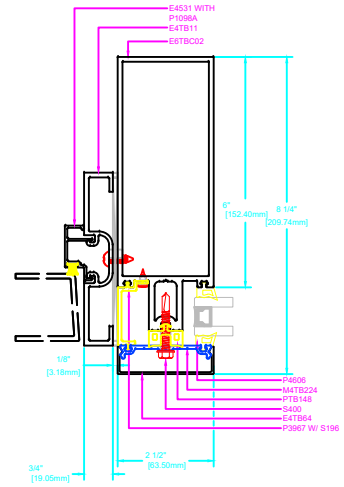

8 STANDARD DOOR JAMB AT SIDELITE W/ VINYL POCKET CLOSER

VERTICAL DETAILS

Standard Details
1/5 scale

September 2022



For specific product applications, contact your representative.
www.alumicor.com PAGE 2 www.tubeliteinc.com



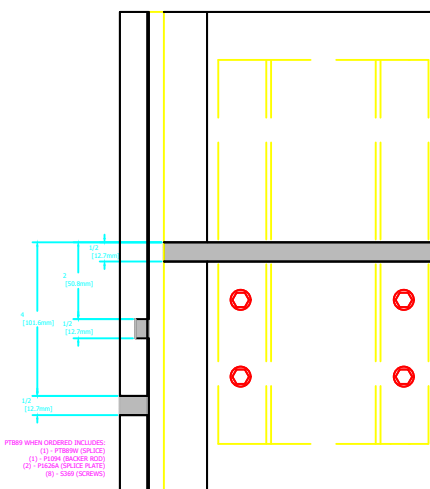
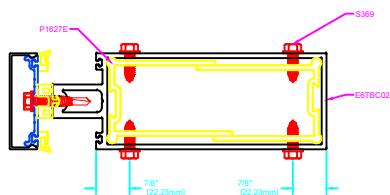

11
STANDARD
CAPTURED VERTICAL SPLICE

SPLICE AND ANCHOR DETAILS

Standard Details
1/5 scale

September 2022

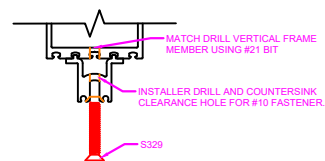
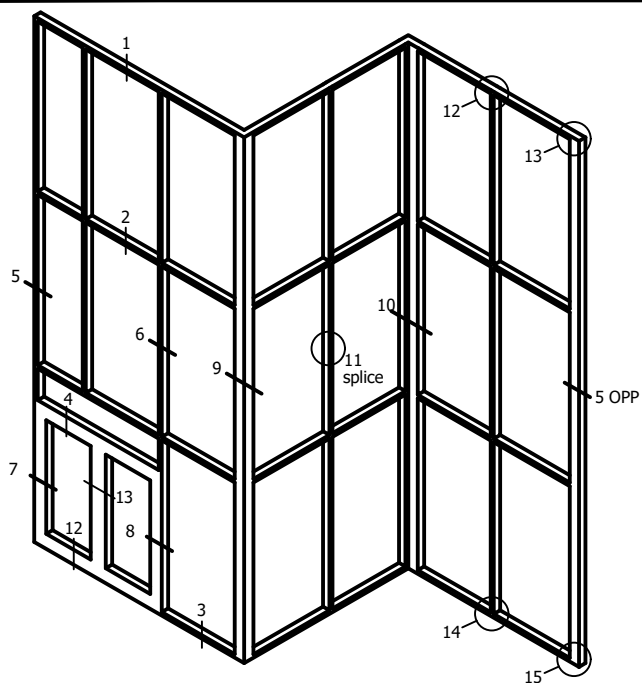

SCREW APPLIED HORN

FACE COVER PINNING

TYPICAL ELEVATION

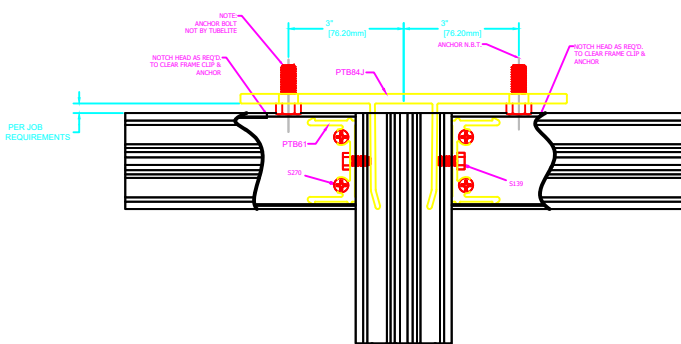

12
STANDARD
"T" ANCHOR AT HEAD

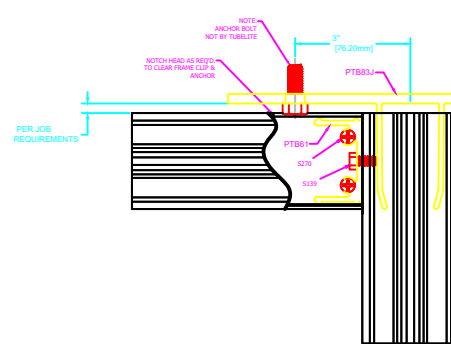

13
STANDARD
"F" ANCHOR AT HEAD

NOTE: Use S369 at non-exposed locations, use S6505 at exposed locations.

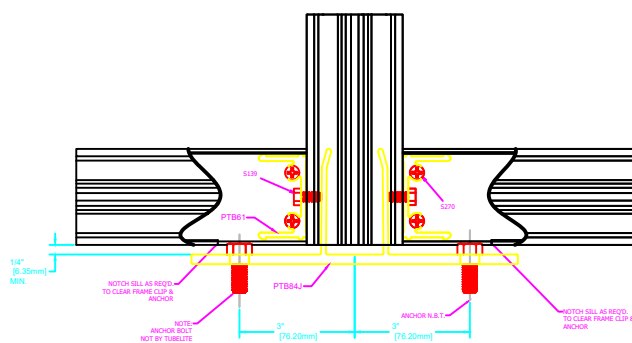

14
STANDARD
"T" ANCHOR AT SILL

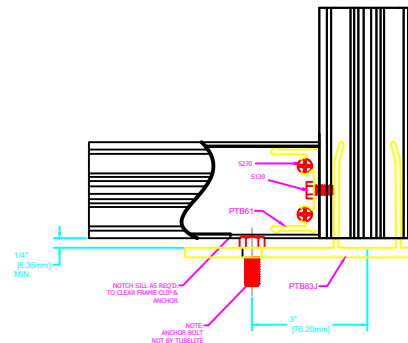

15
STANDARD
"F" ANCHOR AT SILL

SPLICE AND ANCHOR DETAILS

Standard Details
1/5 scale

September 2022