

400 SERIES CURTAIN WALL

INSTALLATION INSTRUCTIONS

3056 Walker Ridge Dr. NW, Suite G • Walker, Mi 49544 • 800-866-2227

BLANK

TABLE OF CONTENTS

GENERAL CONSTRUCTION NOTES 4-5

QUICK REFERENCE CHECKLIST 5

PARTS LIST 6-10

ELEVATION TYPES and DETAILS 12-21

FRAME FABRICATION

 Step 1 Determine Frame Size 22

 Step 2 Cut Material to Length 23-24

 Step 3 Drill Verticals for Shear Blocks 25

 Step 4 Drill Horizontals for Shear Block Attachment 26

 Step 5 Fabricate Pressure Bars 27

 Step 6 Fabricate Weep Holes in Face Covers 28

 Step 7 Notch Head & Sill for Anchor Clearance 28

 Step 8 Install Steel Reinforcement as Required 29

 Step 9 Fasten Shear Clip to Vertical 30

 Step 10 Fasten Head and Sill Anchor Clips 30

 Step 11 Fasten Head and Sill Anchor Clips at 'F' and 'T' Anchor Conditions 31

FRAME INSTALLATION

 Step 12 Installing Vertical Mullions 32-33

 Step 13 Splice Sleeve Installation 34

 Step 14 Attach Horizontals to Shear Blocks and Anchor Clips 35-38

 Step 15 Install Water Dams..... 39-40

 Step 16 Apply Perimeter Seal to Installation 40-41

GLAZING

 Step 17 Glazing Preparation 42

 Step 18 Installing Gaskets 42-43

 Step 19 Installing Glass 44-47

 Step 20 Install Pressure Plates and Face Covers 48-55

TRANSITION GLAZING..... 56

ENTRANCE FRAMING 57-58

REGLAZING 59

CORNER CONDITIONS

 Captured Outside Corner 60

 SSG Outside Corner 61

 SSG Inside Corner 62

GENERAL CONSTRUCTION NOTES

1. These instructions cover typical product application, fabrication, installation and standard conditions and are general in nature. They provide useful guidelines, but the final shop drawings may include additional details specific to the project. Any conflict or discrepancies must be clarified prior to execution.
2. Materials stored at the job site must be kept in a safe place protected from possible damage by other trades. Stack with adequate separation so materials will not rub together and store off the ground. Cardboard or paper wrapped materials must be kept dry. Check arriving materials for quantity and keep a record of where various materials are stored.
3. All field welding must be done in accordance with AISC guidelines. All aluminum and glass should be shielded from field welding to avoid damage from weld splatter. Results will be unsightly and may be structurally unsound. Advise general contractor and other trades accordingly.
4. Coordinate protection of installed work with general contractor and/or other trades.
5. Coordinate sequence of other trades which affected framing installation with the general contractor (e.g. fire proofing, back up walls, partitions, ceilings, mechanical ducts, HVAC, etc.).
6. General contractor should furnish and guarantee bench marks, off set lines and opening dimensions. These items should be checked for accuracy before proceeding with erection. Make certain that all adjacent substrate construction is in accordance with the contract documents and/or approved shop drawings. If not, notify the general contractor in writing before proceeding with installation because this could constitute acceptance of adjacent substrate construction by others.
7. Isolate all aluminum to be placed directly in contact with masonry or other incompatible materials with a heavy coat of zinc chromate or bituminous paint. Fasteners attaching framing to building structure are typically not provided by Tubelite, nor specified in these instructions due to varying perimeter conditions and job performance requirements. Consult approved shop drawings.
8. Sealant selection is the responsibility of the erector, installer and/or glazing contractor and must be approved by the sealant manufacturer with regard to application and compatibility for its intended use. All sealants must be used in strict accordance with the manufacturer's instructions and applied only by trained personnel to surfaces that have been properly prepared.
9. Sealant must be compatible with all materials with which they have contact, including other sealant surfaces. Consult the sealant manufacturer for recommendations relative to shelf life, compatibility, cleaning of substrate, priming, tooling/adhesion, etc. Recommend sealant manufacturer perform adhesion "pull test" at "wet" glazing for quality assurance.
10. Drainage gutters and weep holes must be kept clean at all times. Tubelite will not accept responsibility for improper drainage as a result of clogged gutters and weep holes.
11. This product requires clearances at the head, sill and jambs to allow for thermal expansion and contraction as well as construction tolerances. Refer to final distribution drawings for joint sizes. Joints smaller than 1/4" (6.3mm) may be subject to failure. Consult the sealant manufacturer for proper sizing of joints.
12. All framing members, entrances and other materials are to be installed plumb, level and true with regard to established bench marks, column center lines or other working points established by the general contractor and checked by the erector, installer and/or glazing contractor.
13. After sealant is set and a representative amount of the wall has been glazed (500 square feet or more), run a water hose test to check installation. On large projects, a hose test should be repeated during glazing operation. This testing should be conducted in accordance with AAMA 501.2 specifications.
14. Cleaning of exposed aluminum surfaces should be done per AAMA recommendations.
15. Check www.tubeliteinc.com for any installation instruction updates.

GENERAL CONSTRUCTION NOTES

THERMAL PRESSURE PLATE INSTALLATION









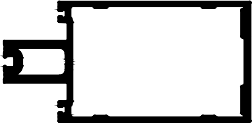

Tubelite's THERMAL (PTB120) pressure plates can be used in place of the standard aluminum pressure plate for improved thermal performance. Please note the following important information while planning your project.

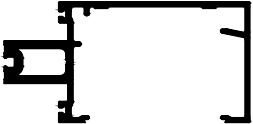



- ALL anchor holes must be utilized for proper load distribution.
 - Thermal pressure plates do not require special tooling for cutting and drilling, however, carbide tipped blades are recommended for cutting or diamond tip blades for better longevity.
 - The same protective wear (i.e. gloves, safety goggles, etc.) worn to fabricate aluminum pressure plates can be worn to fabricate thermal pressure plates. Protective wear guidelines for PTB120 thermal pressure plates can be found online in the MSDS.
 - Tubelite offers one typical aluminum corner cover (E4TB57) that is designed for the corner aluminum pressure plate. Nominal dimension from face of glass to face of cover measures 3/4" (19mm).
 - A PVC pocket filler (P3967) has been designed to be used at perimeter members where a return leg pressure plate is not available.
1. Make sure the opening is square and the caulk joints are 1/2" (12.7mm) minimum around the frame.
 2. Ensure surfaces that will be sealed are free of contaminants that can lead to adhesion issues.
 3. Check that all weeps and baffles (if required) conform to the locations and sizes called out in these instructions.
 4. Butter seal ends of horizontal frame members that are joined to vertical members.
 5. Water dam installation and sealing is critical. Check installation against instructions to ensure conformity.
 6. Apply sealant between all corner gasket joints.
 7. Glass bites must be equal on all sides.
 8. Double check anchor size and location against installation instructions or approved shop drawings.
 9. Ensure pressure plate fasteners are torqued to 60 in-lbs.

GLASS SIZE CALCULATION

Captured Mullions	= D.L.O. + 1" (25.4mm)
SSG Vertical Mullions	= D.L.O. + 2" (50.8mm)
SSG Horizontal Mullions	= D.L.O. + 1 3/4" (44.5mm)
SSG Vertical Mullion at Captured Jamb	= Width ONLY D.L.O. + 1 1/2" (38.1mm)
Corner Mullions	= See Approved Shop Drawings

TYPICAL FRAMING EXTRUSIONS

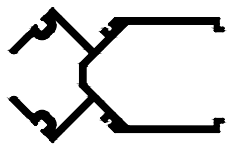
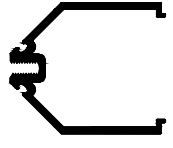
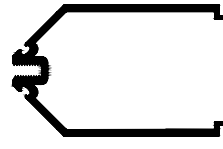
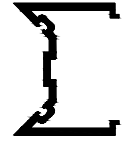
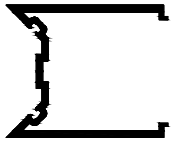
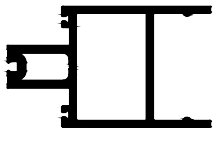
SHAPE	DESCRIPTION	PART No.
	4"[101.6mm] Tubular Captured Mullion/Horizontal	E4TBC223
	4" [101.6mm] Tubular Butt Glaze Mullion (Interior Structural Seal)	E4TB128
	4" [101.6mm] Tubular Butt Glaze Mullion (Interior or Exterior Structural Seal)	E4TB262
	4" [101.6mm] Roll-Over Horizontal	E4TBC173
	4" [101.6mm] Roll-Over Filler	E4TB175
	4" [101.6mm] Head/Sill Perimeter	E4TBC245
	Thermal Pressure Plate	PTB120
	Intermediate Pressure Bar	M4TB224
	Perimeter Pressure Bar	M4TB225
	3/4" [19mm] Depth Cap (Standard)	E4TB64
	Captured Corner Face Cover (Aluminum)	E4TB58

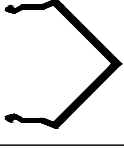
SHAPE	DESCRIPTION	PART No.
	Glazing Pocket Filler	E3192
	1/4" [6.3mm] Spandrel Glass Adaptor for Captured Glazing	E4TB69
	1/4" [6.3mm] Spandrel Glass Adaptor for SSG Glazing	E4TB129
	90° Outside Corner Adaptor for Captured Glazing	E4TBC52
	90° Outside Corner Adaptor for SSG Glazing	E4TB53
	90° Outside Corner Adaptor for SSG Glaze 1/4" [6.3mm] Spandrel Glass	E4TB55
	90° Inside Corner Adaptor for Butt Glaze	E4TB54
	90° Inside Corner Adaptor for SSG Glaze 1/4" (6.3mm) Spandrel Glass	E4TB56
	4" [101.6mm] Back Member Use with E4TB50 & E4TB51	E4TBC88
	90° Outside Corner Interior Closure	E4TB50
	90° Inside Corner Interior Closure	E4TB51





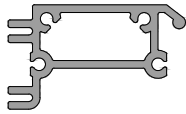
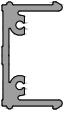
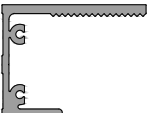
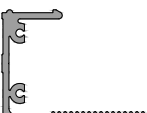
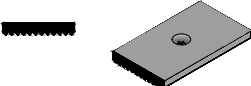
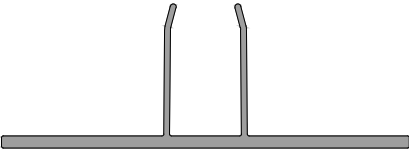
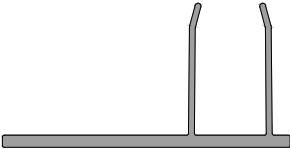





Contact Tubelite for additional system extrusions for enhanced project applications.
 Or, visit our web site as at: www.tubeliteinc.com/400-series-curtainwall .

ANCHORS and CLIPS



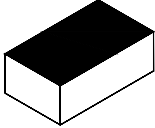
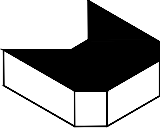

SHAPE	DESCRIPTION	PART No.	
	Shear Clip for Roll-Over Horizontal	PTB110	
	Shear Block for Tubular Horizontals	PTB58	
	Shear Block/Anchor for Head	P2056	
	Shear Block/Anchor for Sill	PTB47	
	Locking Washer Plate for P2056 Shear Block/Anchor	Hole Size	5/16" [7.9mm]
			3/8" [9.5mm]
			7/16" [11.1mm]
	'T' Anchor for Mullions	Captured	PTB84M
		SSG	PTB84Y at E4TB262
		SSG	PTB87B at E4TB128
	'F' Anchor for Jamb	Captured	PTB83M
		SSG	PTB83Y at E4TB262
		SSG	PTB88B at E4TB128

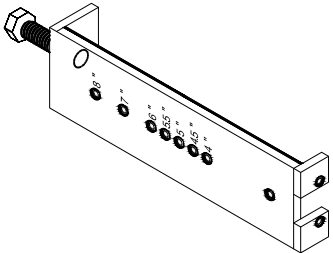
Anchors and Clips shown here are for 4" back members.
 Contact Tubelite for additional parts and back member depths
 or visit our website, www.tubeliteinc.com/400-series-curtainwall/



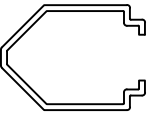
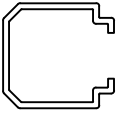

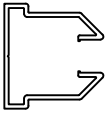

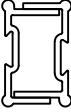
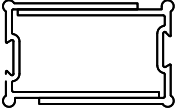
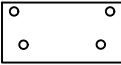
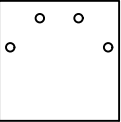





ACCESSORIES

SHAPE	DESCRIPTION	PART No.
	Thermal Isolator Gasket	PTB158
	Glazing Gasket for Captured Glazing	PTB28
	Spacer Gasket for SSG Glazing	PTB106
	Setting Block for 1"(25.4mm) Glazing	P946 (EPDM) P947 (Silicone)
	Setting Block for 1/4" (6.3mm) Glazing	P948
	Temporary Glass Retainer	P1194
	Optional Baffle 1/2" x 1" x 3" [12.7mm x 25.4mm x 76.2mm]	PTB42
	Water Dam for Captured Glazing	PTB93
	Water Dam for SSG Glazing and 90° Captured Corners	PTB76A
	Water Dam for SSG Outside Corner	PTB121
	Water Dam for SSG Inside Corner	PTB122
	Drill Fixture	P2091

ACCESSORIES

SHAPE	DESCRIPTION	PART No.
	SPLICE SLEEVE FOR E4TB52	PTB352
	SPLICE SLEEVE FOR E4TB53	PTB353
	SPLICE SLEEVE FOR E4TB50	PTB350
	SPLICE SLEEVE FOR E4TB51	PTB351
	SPLICE SLEEVE FOR E4TB54	PTB354
	SPLICE SLEEVE FOR E4TB88	PTB17A
	SPLICE SLEEVE FOR E4TB223	P1627B
	MULLION END CAP USE AT JAMB INT MULLION IS 90 CORNER	P4834
	MULLION END CAP USE AT OS 90 CORNER	P4835

FASTENERS

SHAPE	DESCRIPTION	PART No.
	#8 x 3/8" PH Pan Head Type A	S196
	#10-24 x 1/2" PH type 'F'	S128
	#14-14 x 1/2" HH type 'F'	S139
	1/4-20 x 2 1/4" PH MS	S211
	#10-24 x 3/4" PH Self Tapping	S270
	1/4-20 x 1 1/2" HWH type 'F'	S359
	1/4-20 x 1" HWH type 'CA'	S455
	1/4-20 x 1 1/2" HWH Bolt for Corner Mullion Nose at E4TB172	S427
	1/4-20 x 2" HWH Bolt for Corner Mullion Nose at E4TB110	S428
	#12-14 x 1-1/2" HWH 8-18 SELF-DRILL #4 PT for attaching pressure plates to mullion	S400
	1/4-20 x 2-3/4" HWH SCREW for attaching corner adaptors to mullions	S431
	.312 ID x 1.0 OD Flat Washer SS	S437

ELEVATION TYPES

TYPES OF CURTAIN WALL INSTALLATION

The 400 Series curtain wall system can be constructed a variety of ways. The most common are single span, twin span and multi-span as illustrated below. Refer to approved shop drawings for specific guidance on splicing and anchoring.

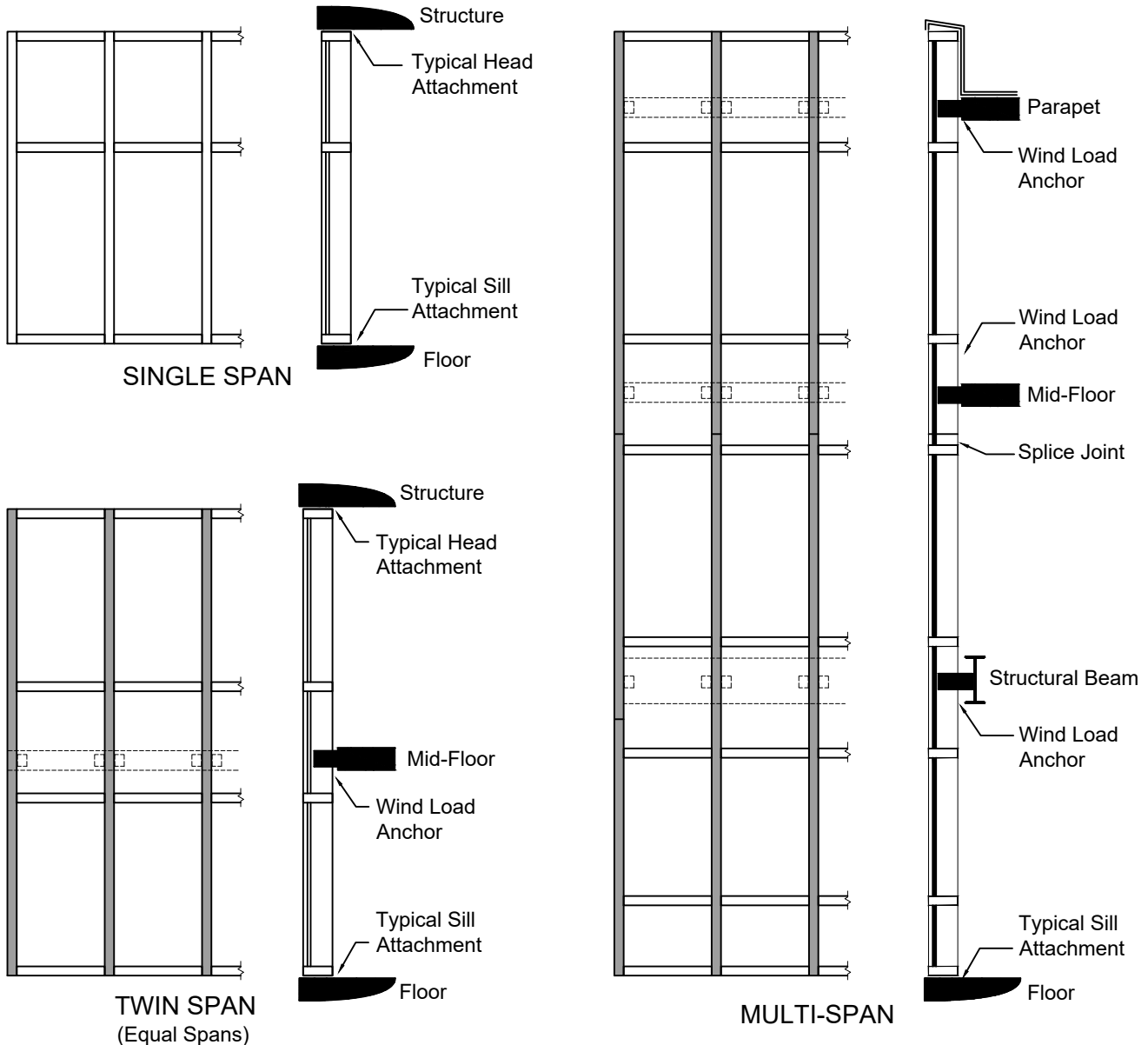

Span configurations will vary per project requirements. Conditions must be approved by engineer calculations.

Fig. 12.1

ELEVATION and WALL SECTIONS

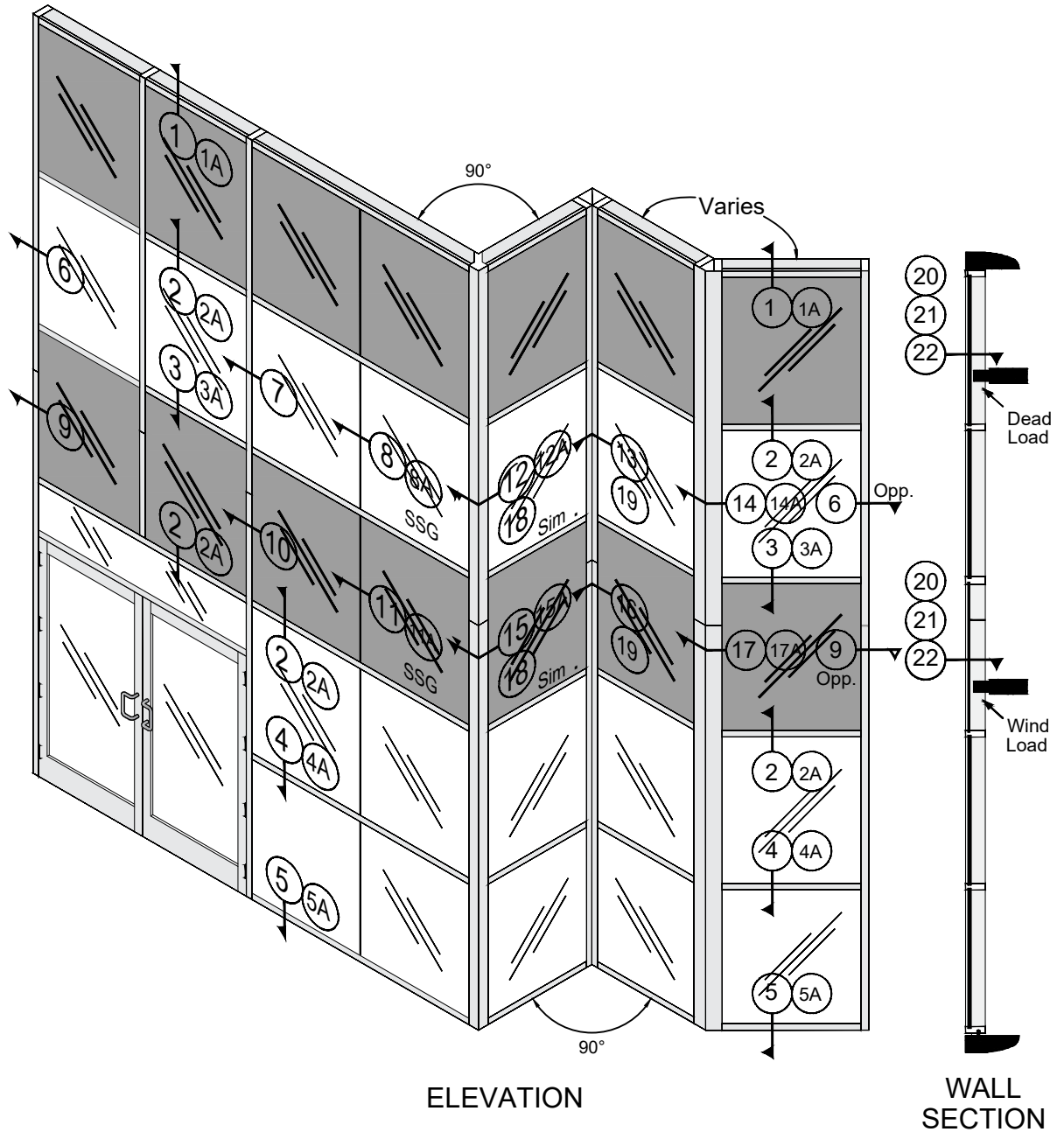

ELEVATION

WALL SECTION

Fig. 13.1

HORIZONTAL DETAILS

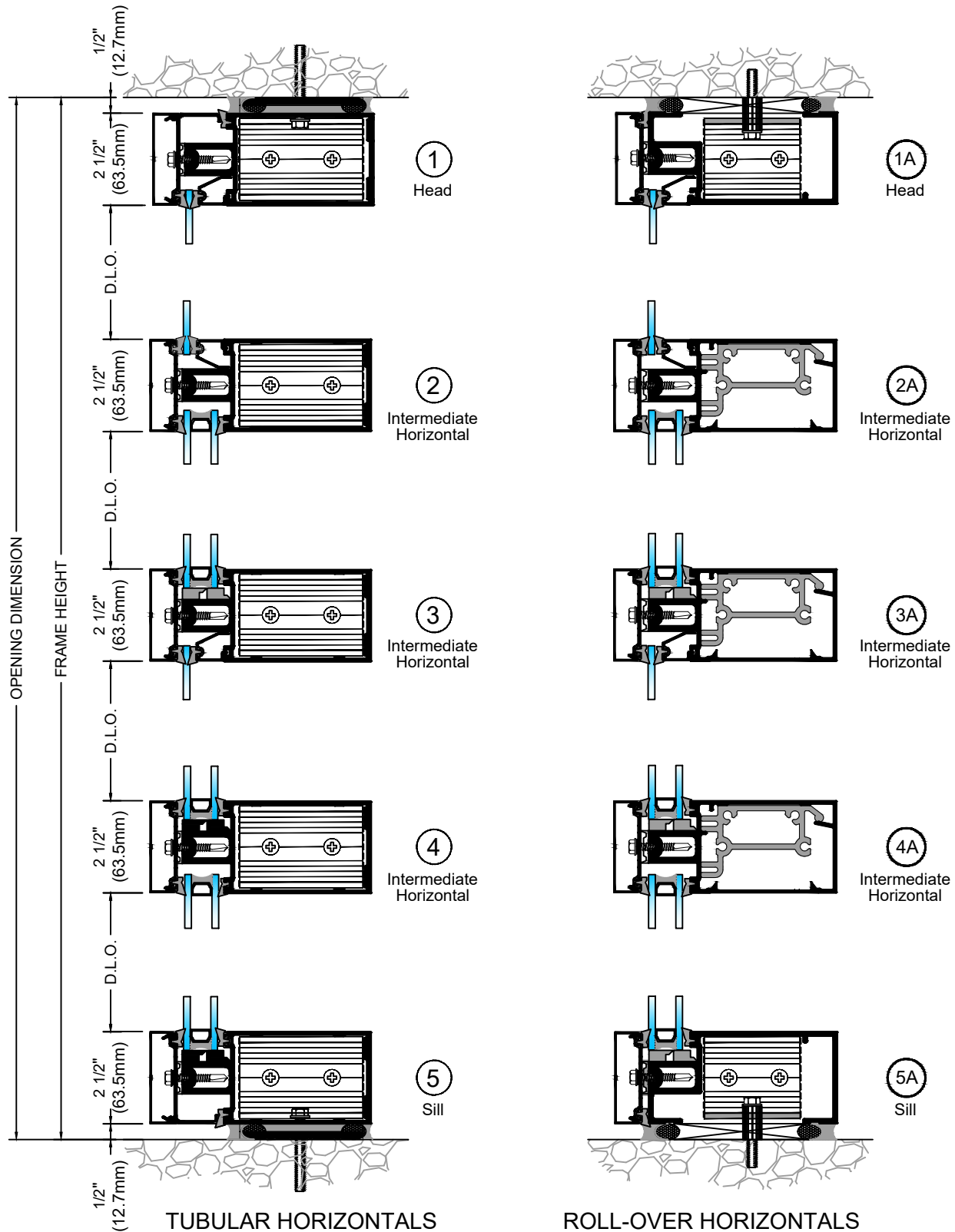

Fig. 14.1

VERTICAL DETAILS

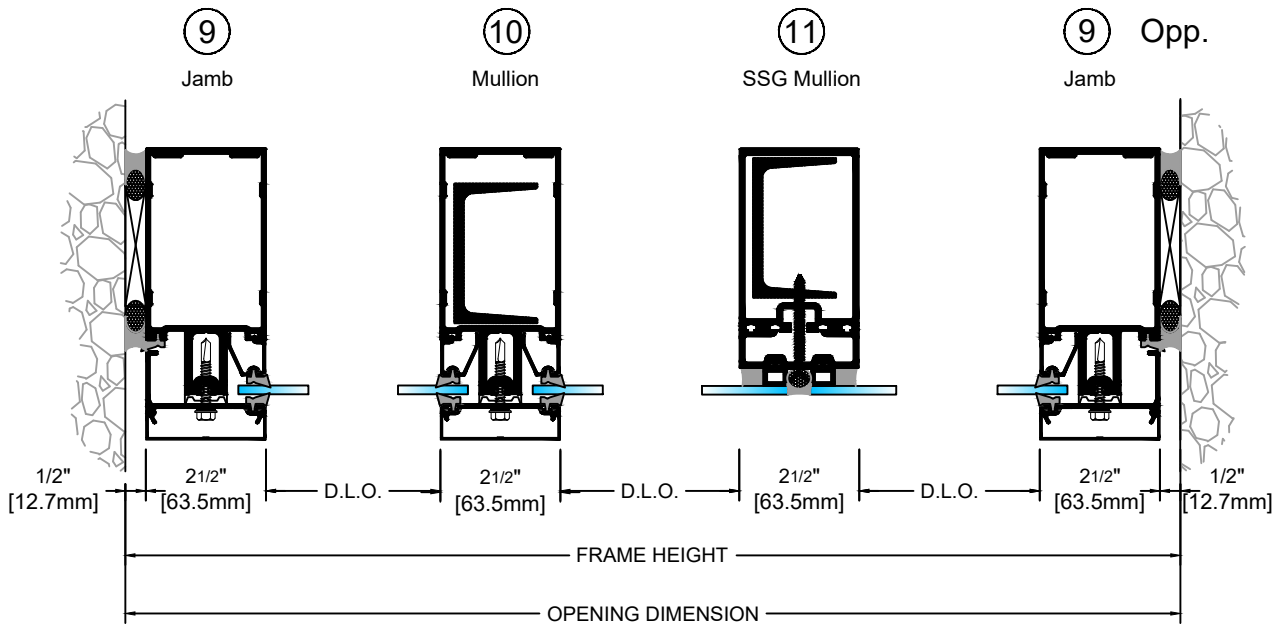
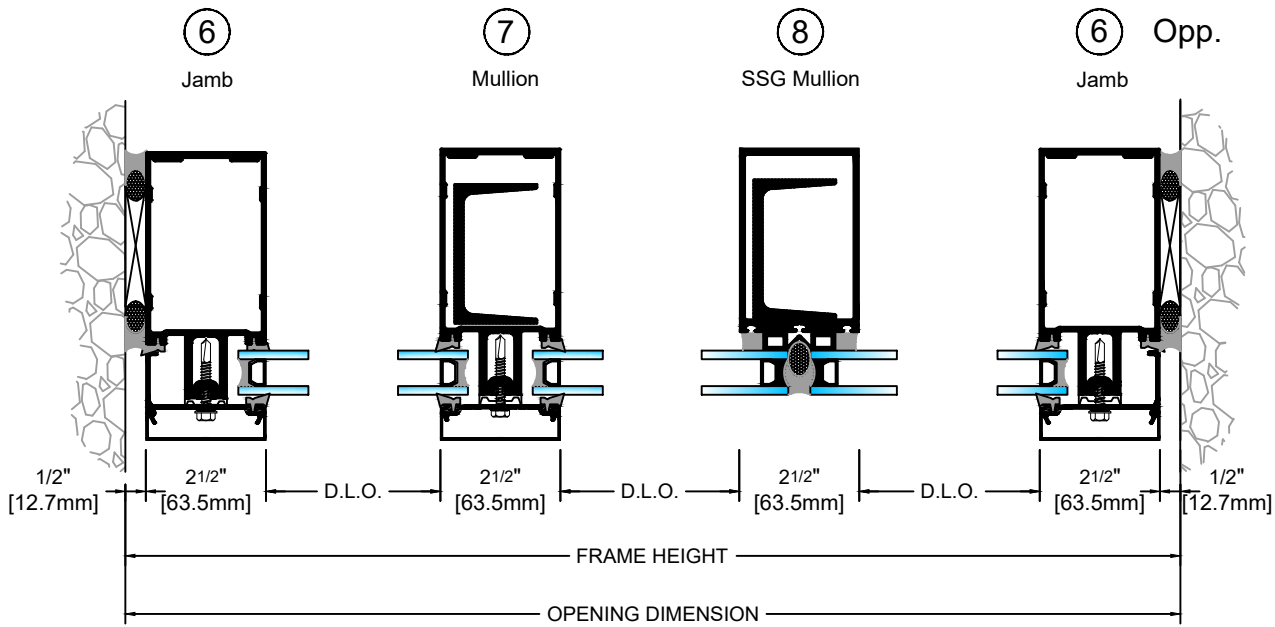

Fig. 15.1

CORNER DETAILS

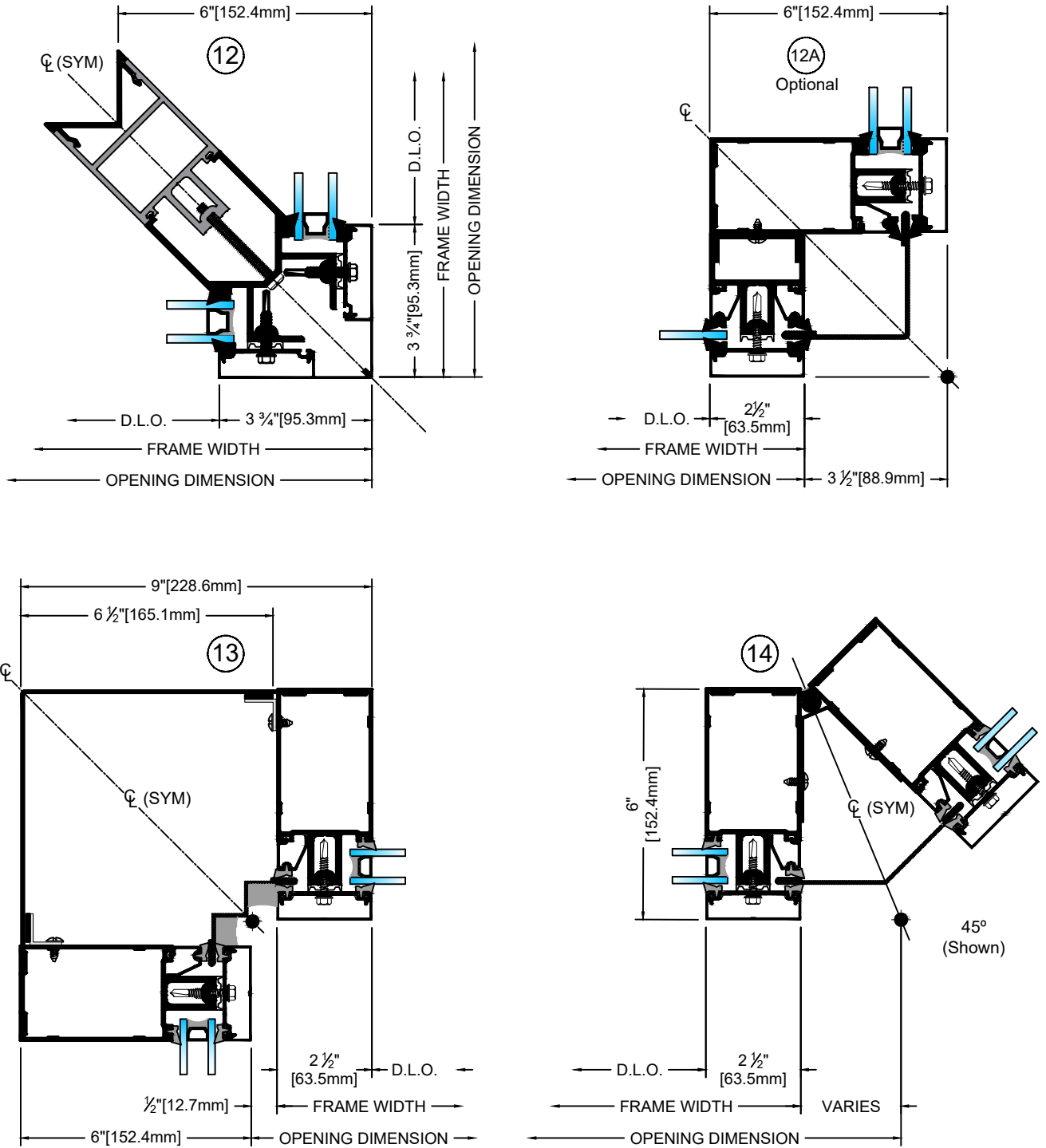

Fig. 16.1

CORNER DETAILS

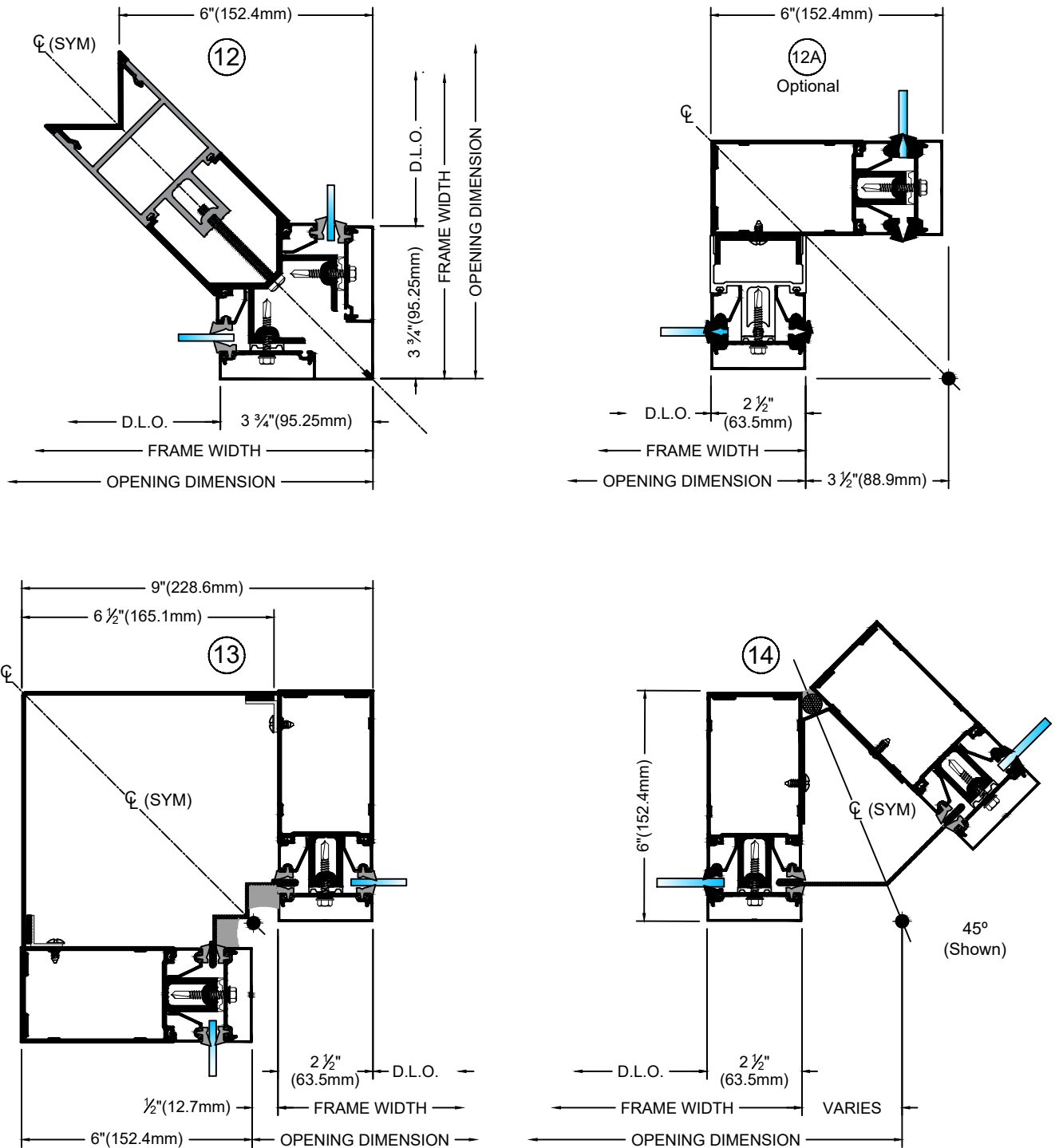

Fig. 17.1

CORNER DETAILS

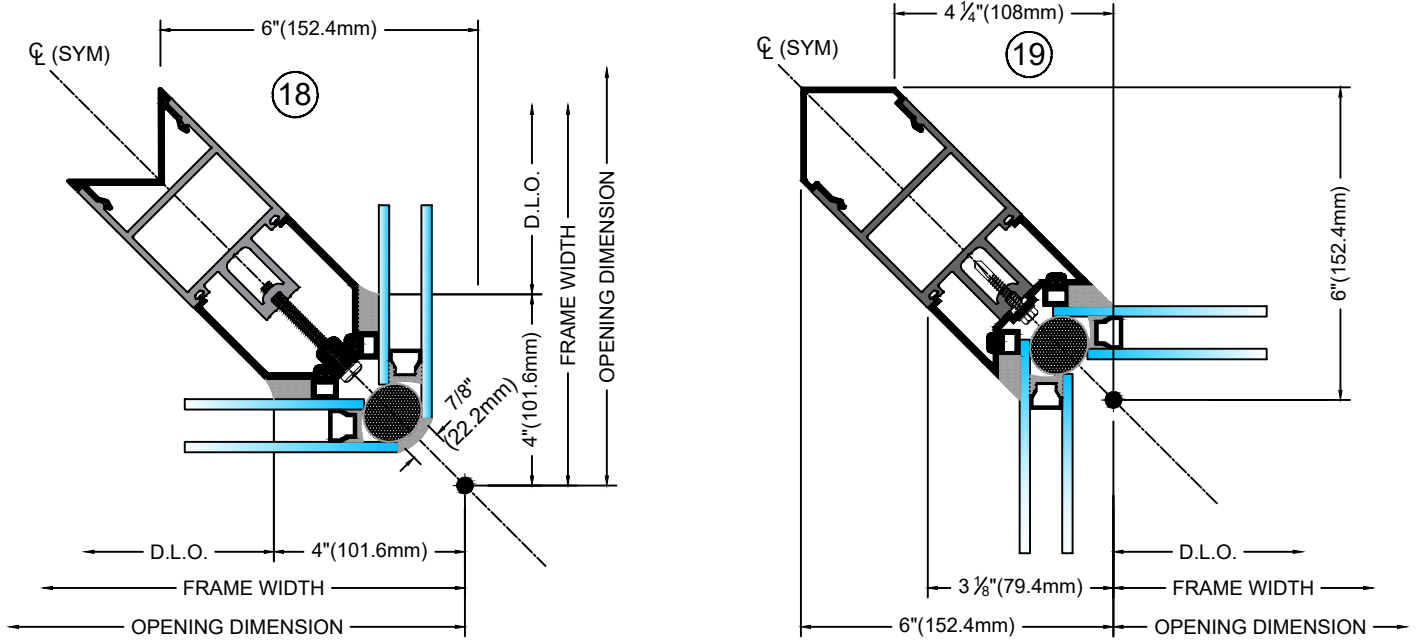

Fig. 18.1

MID-SPAN ANCHOR DETAILS

Anchor details on pages 19 through 21 represent one of several methods of anchoring. Refer to approved shop drawings for job specific applications.

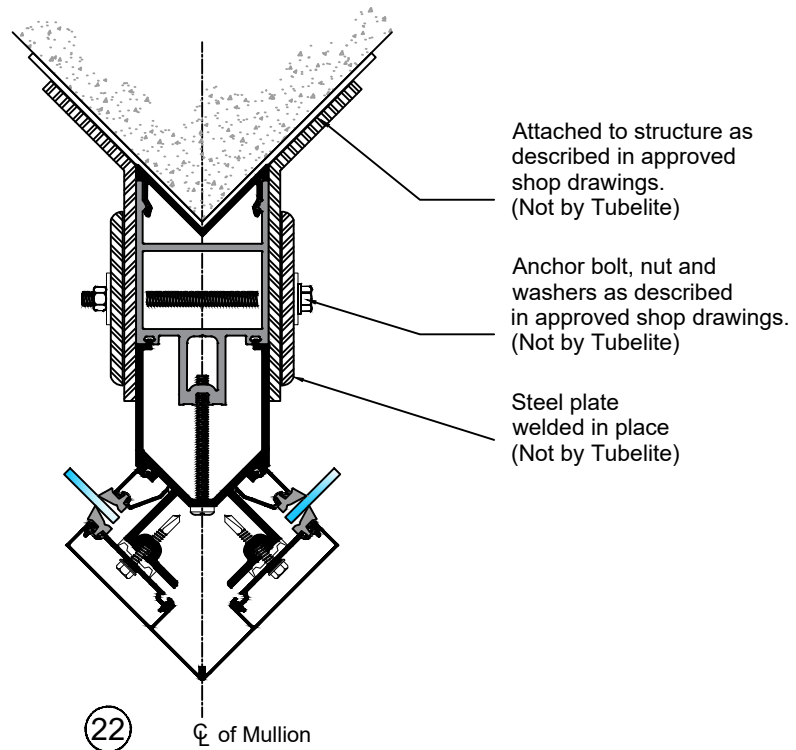
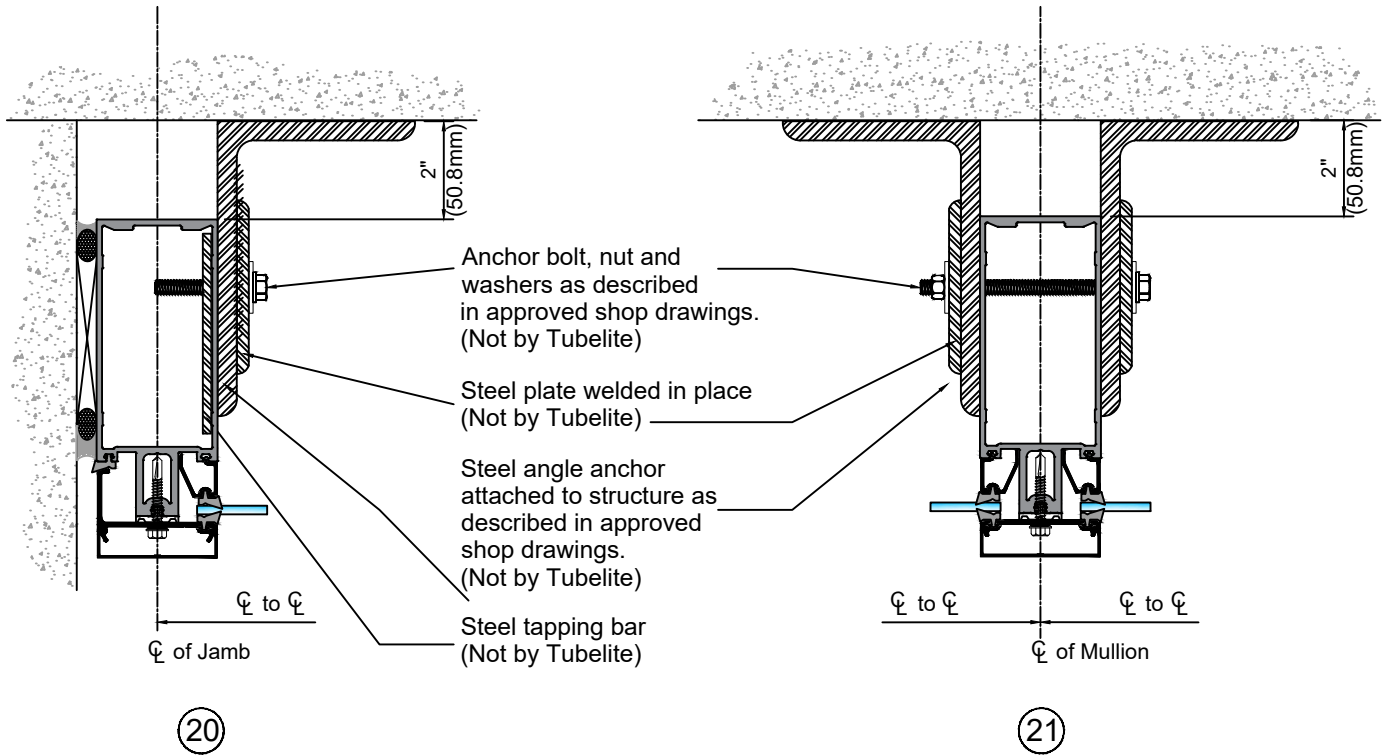

Fig. 19.1

MID-SPAN ANCHOR DETAILS

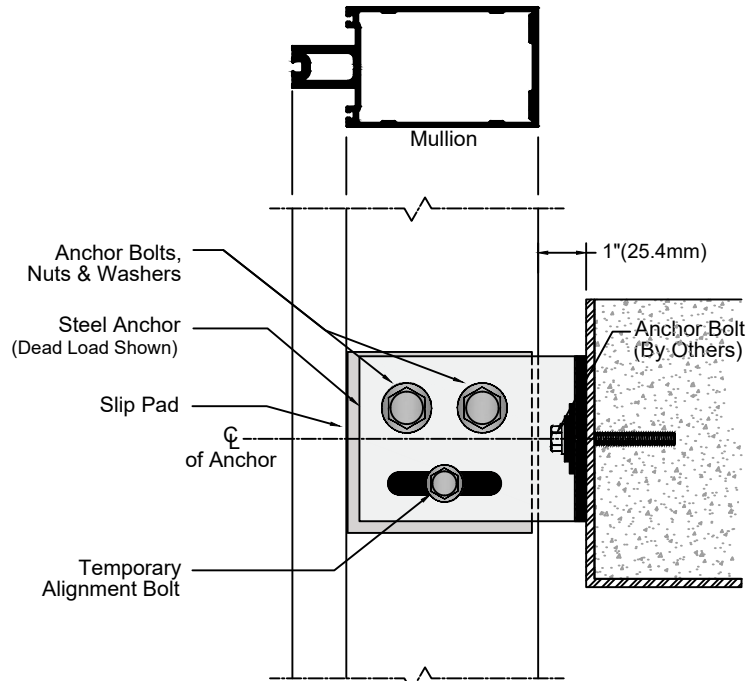

Fig. 20.1
Intermediate Mullion

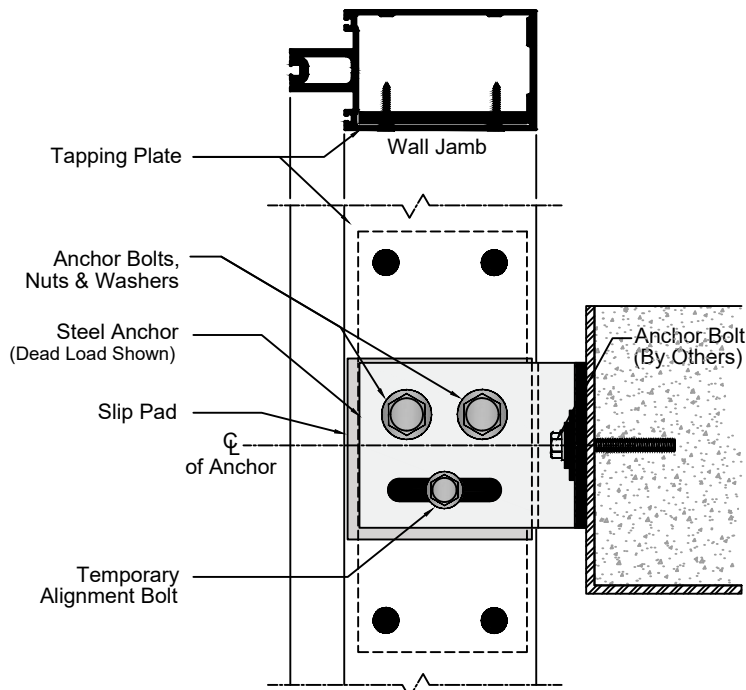
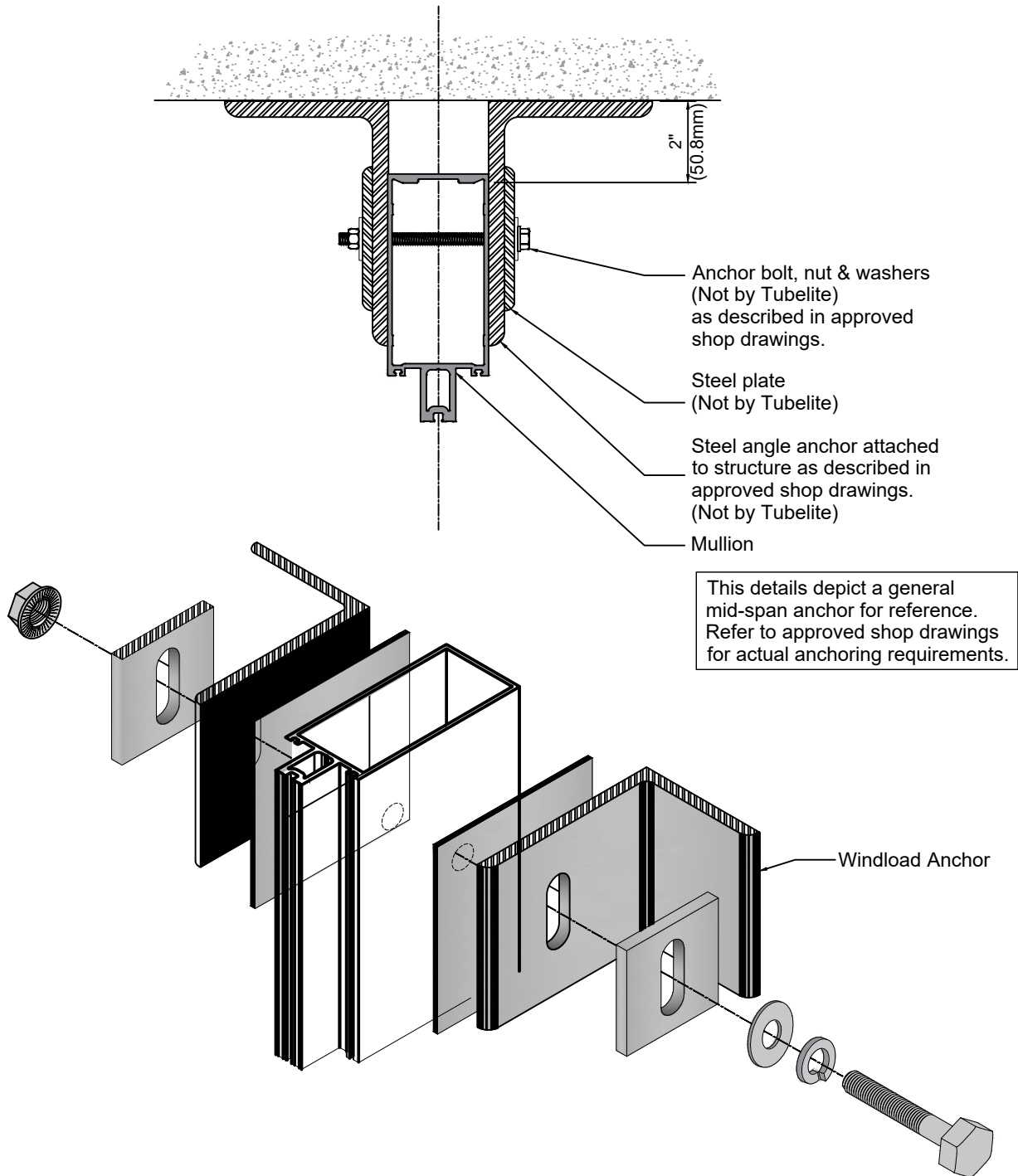

Fig. 20.2
Jamb Mullion

MID-SPAN ANCHOR DETAILS



FRAME FABRICATION

Step 1: Determine Frame Size

Frame Width

- A. Make sure the opening is square and plumb. Measure each diagonal of the opening. SEE Fig. 22.1.
- B. Measure the width of the opening (Rough Opening) at the top, middle and bottom. Select the smallest of these dimensions and subtract the left and right caulk joint width per approved shop drawing (1/2" (12.7mm) minimum caulk joint at jams). SEE Fig. 22.2.
- C. Allow a larger clearance to accommodate building tolerances, an out-of-square opening, anticipated thermal expansion within the unit or as required by shop drawings.

Frame Height

- D. Measure the height of the opening (Rough Opening) at several points along the entire width of the opening. Select the smallest of these dimensions and subtract 1" (25.14mm) to allow a minimum of 1/2" (12.7mm) at sill and head for shim and caulking. SEE Fig. 22.3.
- E. Allow a larger clearance to accommodate building tolerances, an out-of-square opening, anticipated thermal expansion within the unit or as required by shop drawings.

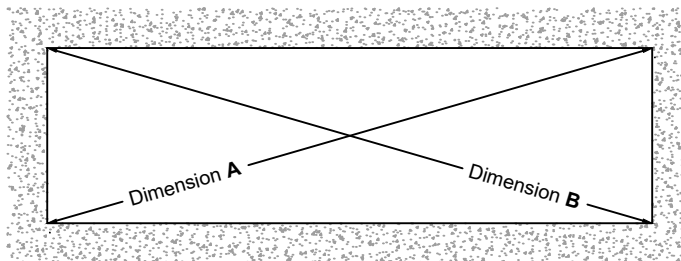

Fig. 22.1

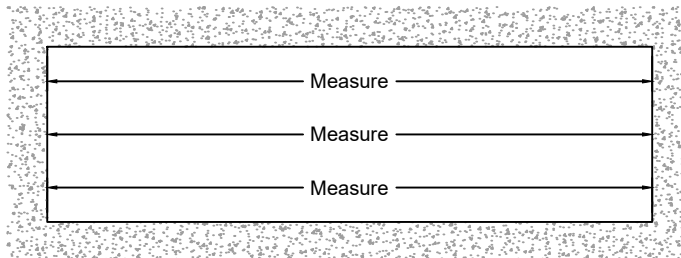

Fig. 22.2

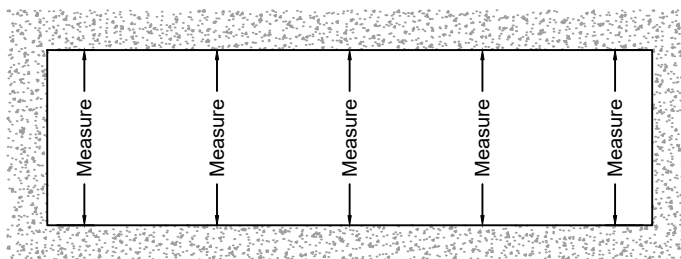

Fig. 22.3

FRAME FABRICATION

Step 2: Captured Framing - Cut Materials to Size

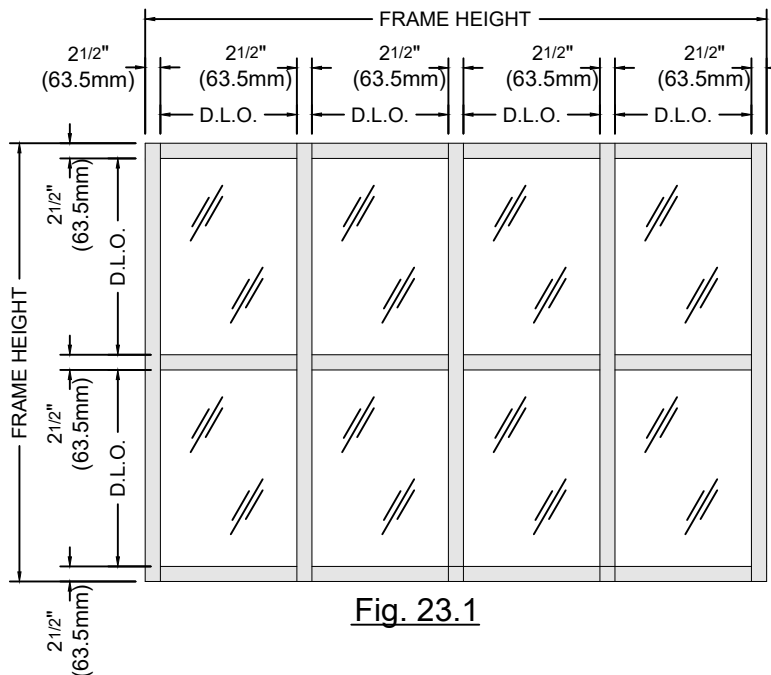

Fig. 23.1

Cut extrusions to lengths as shown below:

Vertical Profiles :

Vertical Mullion	= Frame Height	For frames that receive vertical splicing, see step 20, page 53.
Pressure Plates	= Frame Height	
Face Caps	= Frame Height	
Glazing Adaptors	= D.L.O. PLUS (+) 1"(25.4mm)	
Pocket Filler at Perimeter	= D.L.O. MINUS (-) 1/16"(1.6mm) (used with PTB120 thermal pressure plate)	

Horizontal Profiles :

Tubular Head, Sill & Horizontal	= D.L.O.
Open Back Head, Sill & Horizontal	= D.L.O. MINUS (-) 1/32"(0.8mm)
Pressure Plates	= D.L.O. MINUS (-) 3/8"(9.5mm)
Face Caps	= D.L.O. MINUS (-) 1/32"(0.8mm)
Glazing Adaptors	= D.L.O. MINUS (-) 1/32"(0.8mm)

Accessories:

Exterior Vertical Gasket	= Pressure Plate Length PLUS (+) Allowance*
Exterior Horizontal Gasket	= Pressure Plate Length PLUS (+) Allowance*
Interior Vertical Gasket	= D.L.O. PLUS (+) 1"(25.4mm) PLUS (+) Allowance*
Interior Horizontal Gasket	= D.L.O. PLUS (+) Allowance*

*Allowance = 1/8"(3.2mm) extra length per foot of D.L.O. or aluminum length

Note: Door framing material is cut to size from the factory. In cases of door frames with transoms, the door jambs must be cut down in the field to size and head member attached per standard instructions shown within this manual.

FRAME FABRICATION

Step 2: Structural Silicone Framing - Cut Materials to Size

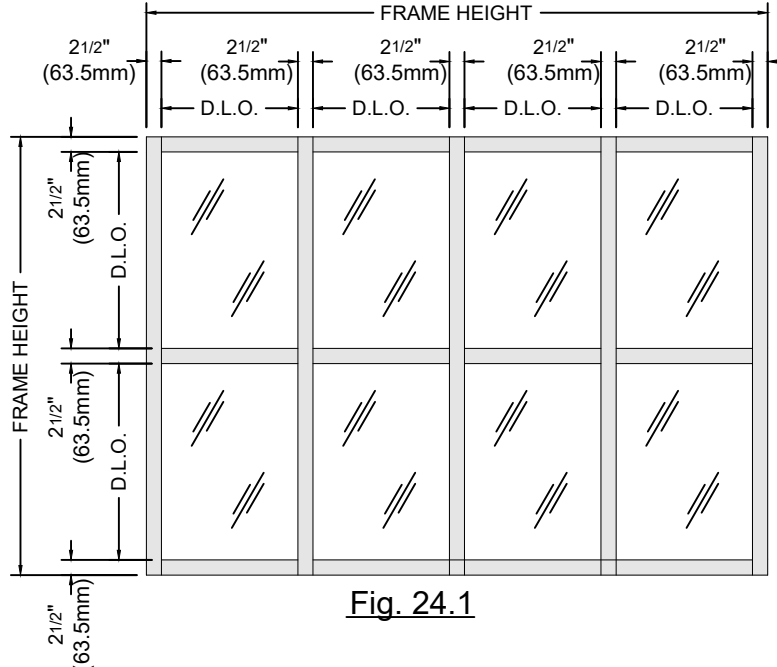

Cut extrusions to lengths as shown below:

Vertical Profiles :

Vertical Mullion	= Frame Height	For frames that receive vertical splicing, see step 20, page 53.
Pressure Plates (at Jambs)	= Frame Height	
Face Caps (at Jambs)	= Frame Height	
Glazing Adaptors	= D.L.O. PLUS (+) 1" (25.4mm)	
Pocket Filler at Perimeter	= D.L.O. MINUS (-) 1/16" (1.6mm) (used with PTB120 thermal pressure plate)	

Horizontal Profiles :

Tubular Head, Sill & Horizontal	= D.L.O.	
Open Back Head, Sill & Horizontal	= D.L.O. MINUS (-) 1/32" (0.8mm)	
Pressure Plates	= 3 Lites Wide Maximum	For frames that receive vertical splicing, see step 20, page 50.
Face Caps	= 3 Lites Wide Maximum	
Glazing Adaptors	= D.L.O. MINUS (-) 1/32" (0.8mm)	

Accessories:

Exterior Vertical Gasket (at Jambs)	= Pressure Plate Length PLUS (+) Allowance*
Exterior Horizontal Gasket	= Pressure Plate Length PLUS (+) Allowance*
Interior Vertical Gasket	= D.L.O. PLUS (+) 1" (25.4mm) PLUS (+) Allowance*
Interior Horizontal Gasket	= D.L.O. PLUS (+) Allowance*
Silicone Spacer Gasket (SSG)	= D.L.O. PLUS (+) 1" (25.4mm) PLUS (+) Allowance*

*Allowance = 1/8" (3.2mm) extra length per foot of D.L.O. or aluminum length

FRAME FABRICATION

Step 3: Drill Holes in Vertical Members for Shear Blocks

A. Drill .201" (5.105mm) diameter pilot holes for #14 screws in the vertical members. Use the P2091 drill fixture to locate these holes.

NOTE:
Face of SSG mullions sit back 1/4" (6.3mm) from face of captured mullions. Note this off set when using SSG horizontals with captured mullions.

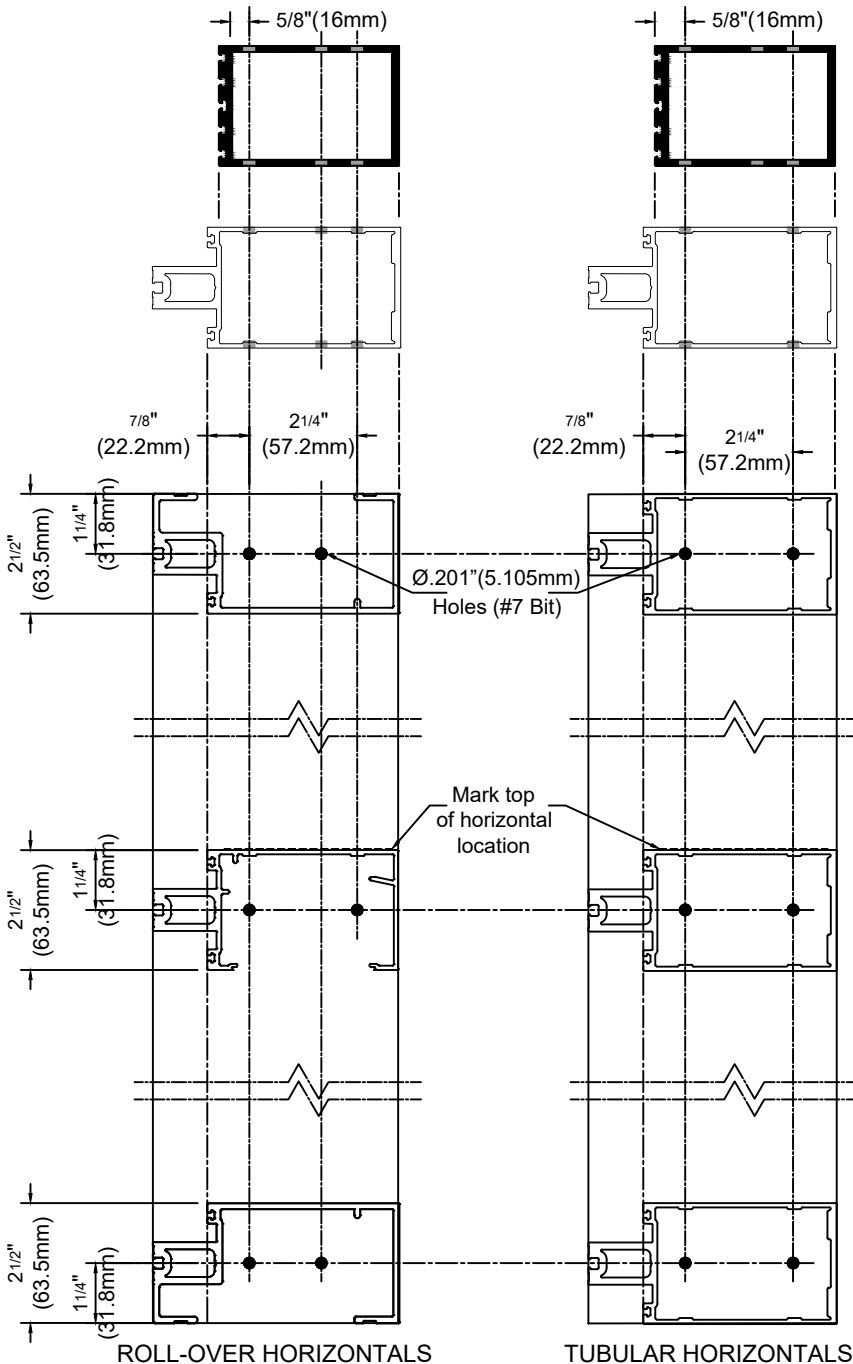

Fig. 25.1

Shear Clip for
Roll-Over Horizontals

Shear Block for
Head/Sill Anchor

Shear Block for

Fig. 25.2

Drill vertical members
for horizontal shear
block attachment.

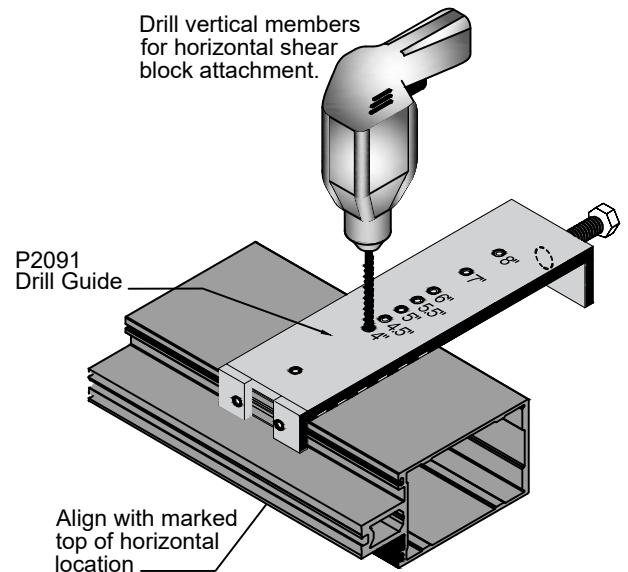

Fig. 25.3

FRAME FABRICATION

Step 4: Drill Holes in Horizontal for Attachment to Shear Blocks

- A. Drill (2) .201" (5.105mm) diameter clearance holes for #10 screws in the horizontal sections for attachment to the shear blocks. Use the P2091 drill fixture to locate holes. Only the top hole is needed in open back head or sill sections.

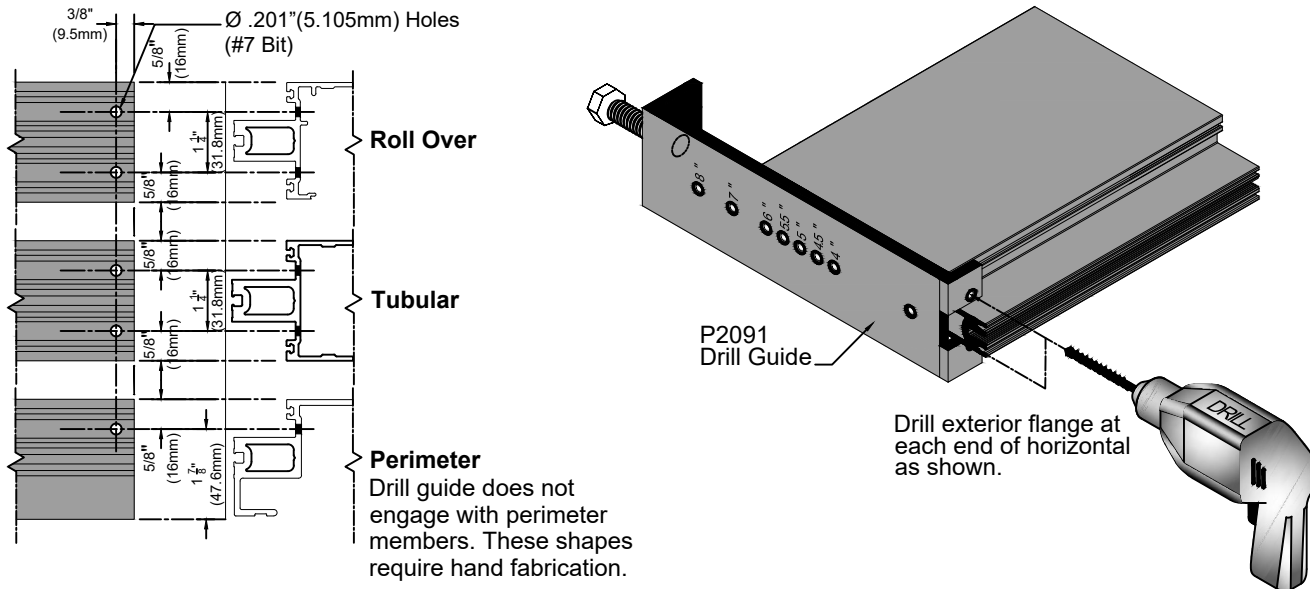

Fig. 26.1

FRAME FABRICATION

Step 5: Drill Weep Holes in Horizontal Pressure Plates

- A. Drill three 5/16"[7.9mm] diameter weep holes per horizontal pressure plate, one at the midpoint and one 4"[101.6mm] from each end as shown on Fig 27.3. When using M4TB224, M4TB225, and PTB120 locate the holes as shown on Fig. 27.4.
- B. Pressure plates are factory punched on center for pressure plate screws. Drill additional hole(s) as required to ensure a maximum of 2"[50.8mm] from the ends of the plates.
- C. When SSG verticals are used in the elevation, horizontal pressure plates can run up to 3 lites wide maximum. Additional weep holes must be drilled in these cases.

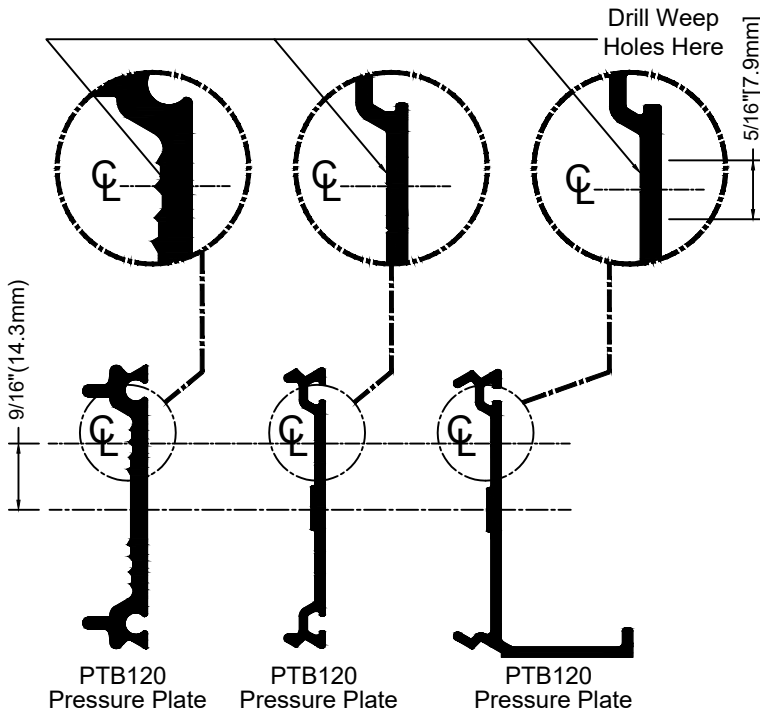

Fig. 27.4

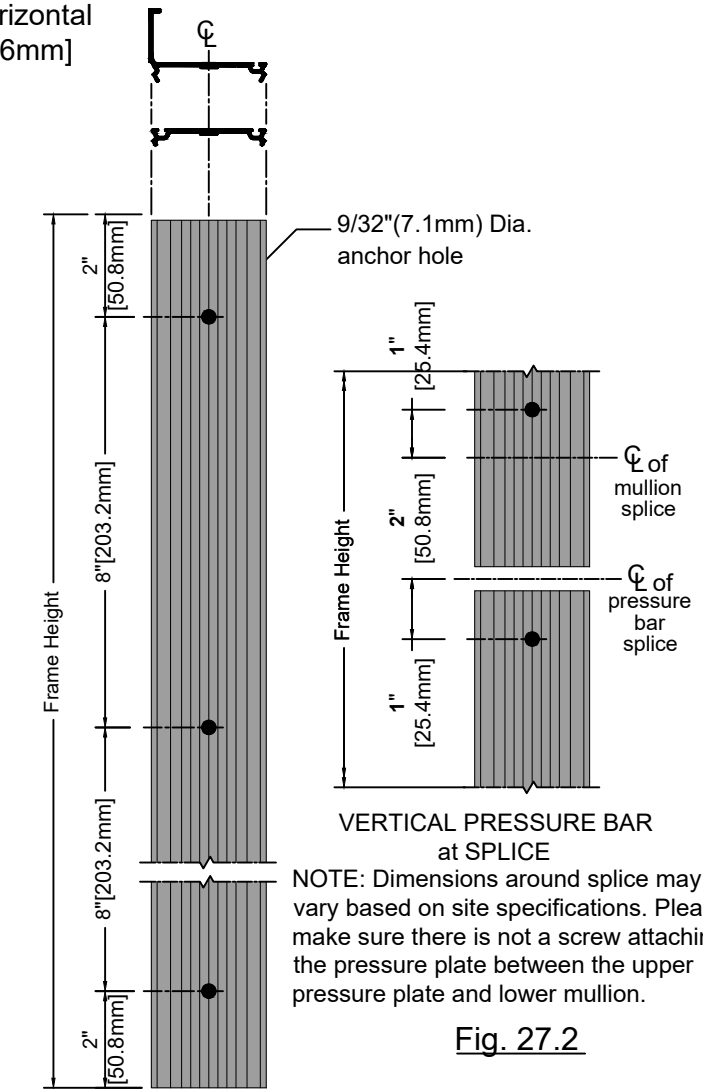

Fig. 27.1

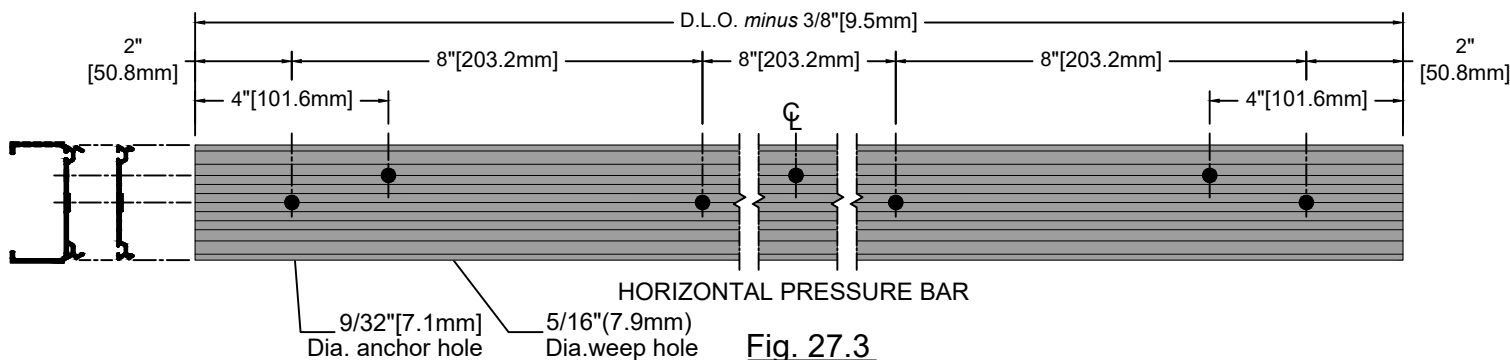

Fig. 27.3

FRAME FABRICATION

Step 6: Fabricate Weep Holes in Horizontal Face Covers

- A. Fabricate a 5/16" [7.9mm] diameter holes on the bottom of each horizontal face cover a maximum of 1" (25.4mm) from each end of the cover.

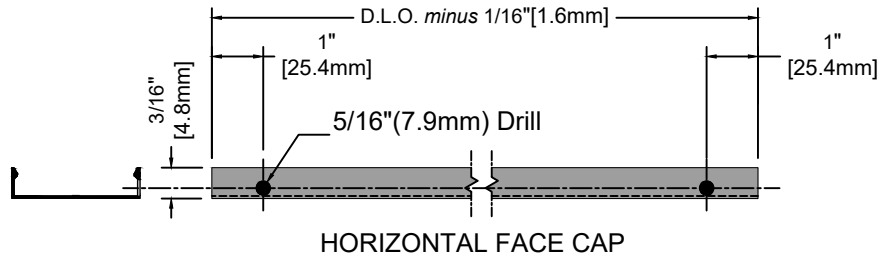

Fig. 28.1

Step 7: Notch Heads and Sills to Clear Anchor Clips (Applies to Tubular Head/Sill Members Only)

- A. Notches must be cut in the head and sill members to provide clearance for the shear blocks. See Fig. 28.2 for proper notch size.

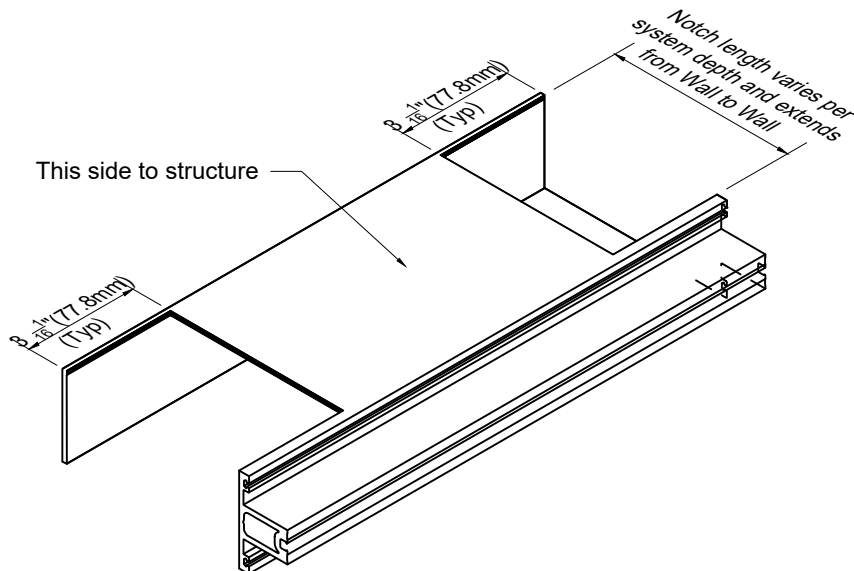

Fig. 28.2

FRAME FABRICATION

Step 8: Install Steel Reinforcement As Required

- A. Refer to approved shop drawings to determine where steel reinforcing may be required.
- B. Steel should be installed prior to the attachment of shear blocks.
- C. If 'T' and 'F' anchors are used, steel should be sized to stop short of the top and bottom of the vertical for clearance.
- D. Locate and prep for attachment of the steel located under the horizontal shear blocks if possible. Otherwise, steel can be secured to the vertical mullion through the tongue. Anchor the steel to the vertical using fasteners and spacing per approved shop drawings (not supplied by Tubelite).

Steel reinforcement shown is for reference only.
See approved shop drawing for steel requirements.

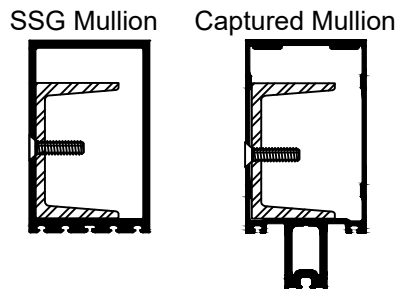

Drill and tap for fastener as required.
Countersink for Flat Head screw.

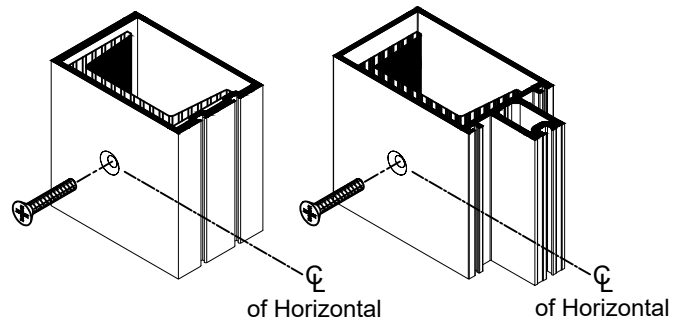

Located fasteners centered
on horizontal location when possible.
See approved shop drawing for requirements.

TYPICAL APPLICATION

Steel reinforcement shown is for reference only.
See approved shop drawing for steel requirements.

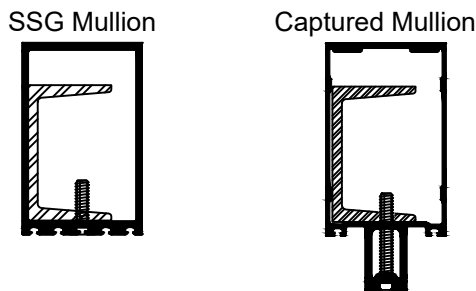

Drill and tap for fastener as required.
Countersink for Flat Head screw.

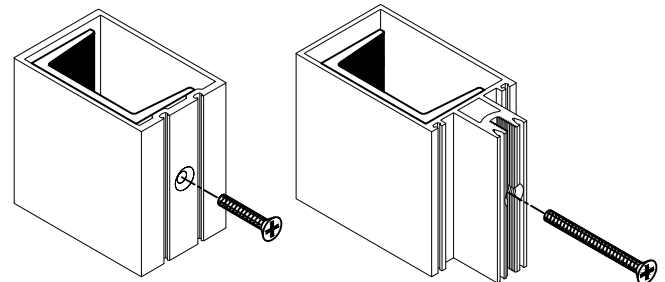

Located fasteners as directed
in approved shop drawings

OPTIONAL APPLICATION

Fig. 29.1

FRAME FABRICATION

Step 9: Fasten Shear Blocks

- A. Fasten the shear blocks for tubular horizontals to the verticals using S139 fasteners.
 - B. Fasten the shear blocks for roll-over horizontals to the verticals using S359 fasteners.
- NOTE: If steel reinforcement is required, it must be installed prior to shear block attachment.

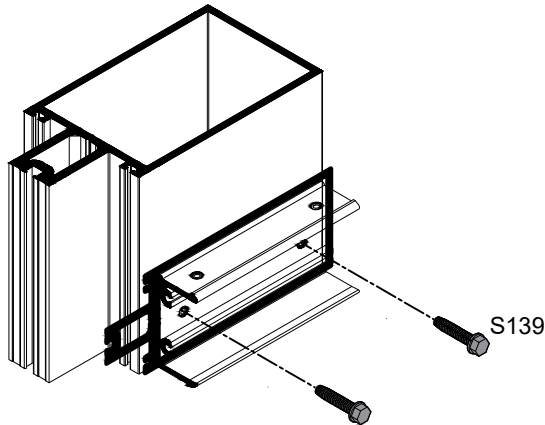

Shear Block for
Tubular Horizontals

Fig. 30.1

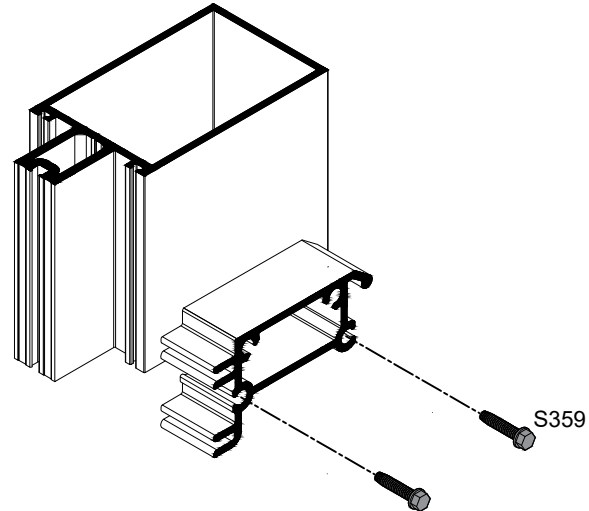

Shear Clip for
Roll-Over Horizontals

Fig. 30.2

Step 10: Fasten Head or Sill Anchor Clips

- A. Fasten the head and sill anchor clip to the vertical mullions using S139 fasteners.
- NOTE: 'T' and 'F' anchors can be used in place of anchor clips. See Step 11 for shear block application when 'T' and 'F' anchors are used.

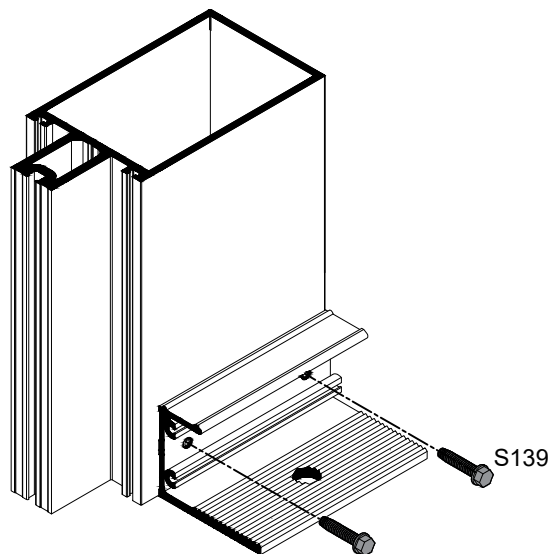

Fig. 30.3

FRAME FABRICATION

Step 11: Fasten Head or Sill Shear Block at F and T Anchor Conditions

- A. Fasten a shear block to the vertical mullion using S139 screws at the head or sill in place of an anchor clip. Refer to Step 9 for shear block installation.
- B. F and T anchors can be pre-loaded into the top and bottom of the verticals and temporarily secured with tape for transit to the job site.

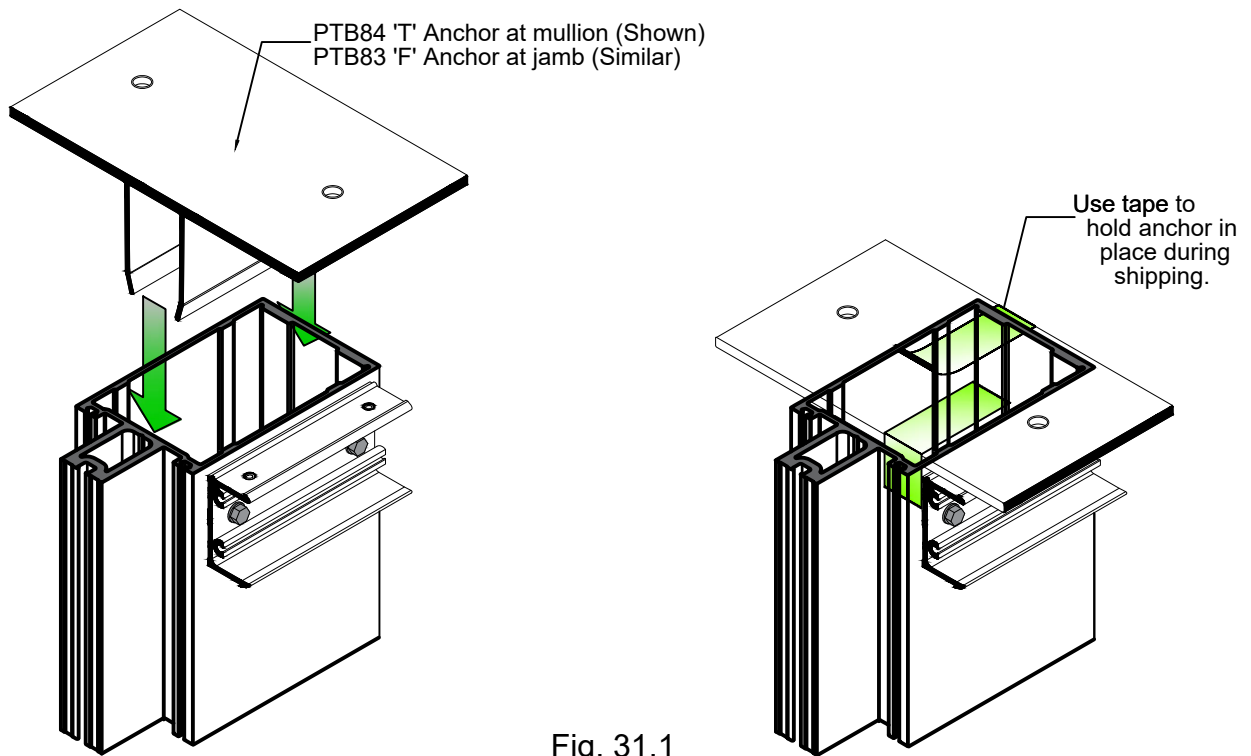

Fig. 31.1

FRAME INSTALLATION

Step 12: Installing Vertical Mullions

NOTE: Check D.L.O. and diagonal dimensions every four bays to ensure correct spacing and frame squareness. When installing tubular horizontals, frame must be stick erected. When installing roll-over horizontals, all verticals can be erected first.

Single Span Installations

Anchor Clip Installation

- A. Install vertical mullions plumb and level, shimming under the verticals at the sill for proper deadload distribution.
- B. Attach the locking lug to the sill anchor clip using a washer and anchor bolt per approved shop drawings (not by Tubelite).
- C. Insert the pipe sleeve at the head anchor clip using a washer and anchor bolt per approved shop drawings (not by Tubelite). NOTE: Do not shim at the head anchor clip to allow for thermal and liveload movement.

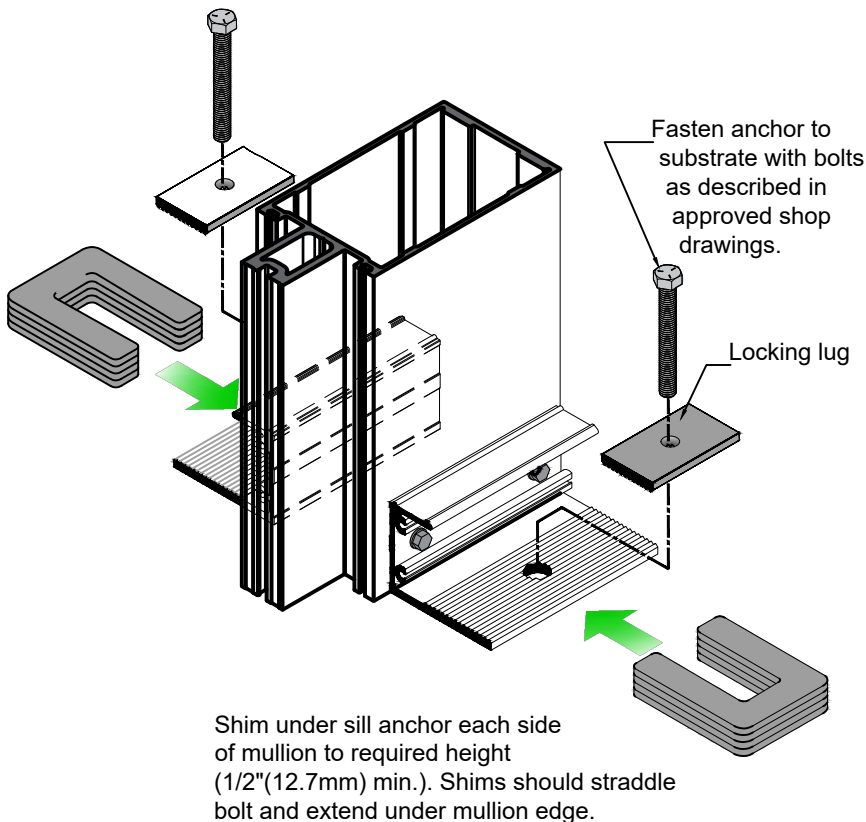

Fig. 32.1

Do not shim between head anchors and structure to allow vertical mullion expansion movement.

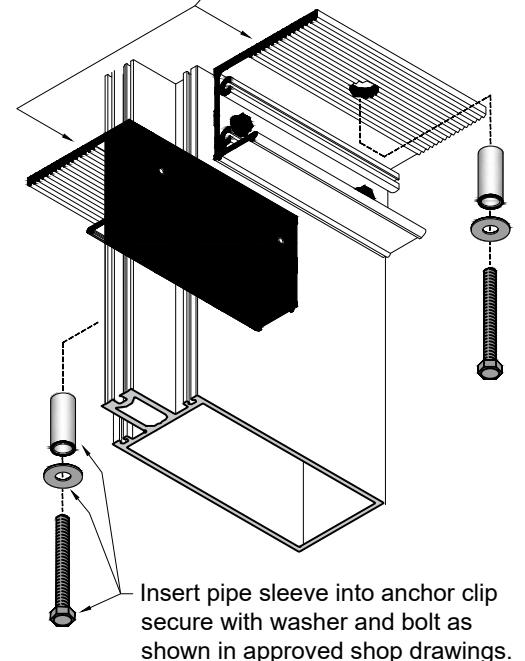

Fig. 32.2

FRAME FABRICATION

Step 12: Installing Vertical Mullions (Continued)

T or F Anchor Installation

- A. Install vertical mullions plumb and level, shimming between the bottom of the vertical and T or F anchor for proper deadload distribution.
 - B. Anchor Top F anchor to building per approved shop drawings.
- NOTE: Do not shim the top of the vertical to allow for thermal and liveload movement.

Multi-Span Installations

NOTE: Tubelite recommends the use of T and F anchors for multi-span installations

- A. Install lower vertical mullion plumb and level, shimming between the bottom of the vertical and T or F anchor for proper deadload distribution.
- B. Anchor T or F anchor to building per approved shop drawings.
- C. At the mid-span anchor, temp the vertical in place plumb and level. Check joint at the mullion splice and use a shim to hold joint at the correct size.
- D. When the entire frame is installed and securely anchored to the mid-span anchor(s), remove shims from the vertical mullion splices and back off nut 1/4 turn at all wind load anchor connections and stake the bolts. Be sure any temporary screws are removed from wind load anchors.
- E. Refer to Step 13, page 34 to complete the splice sleeve installation.

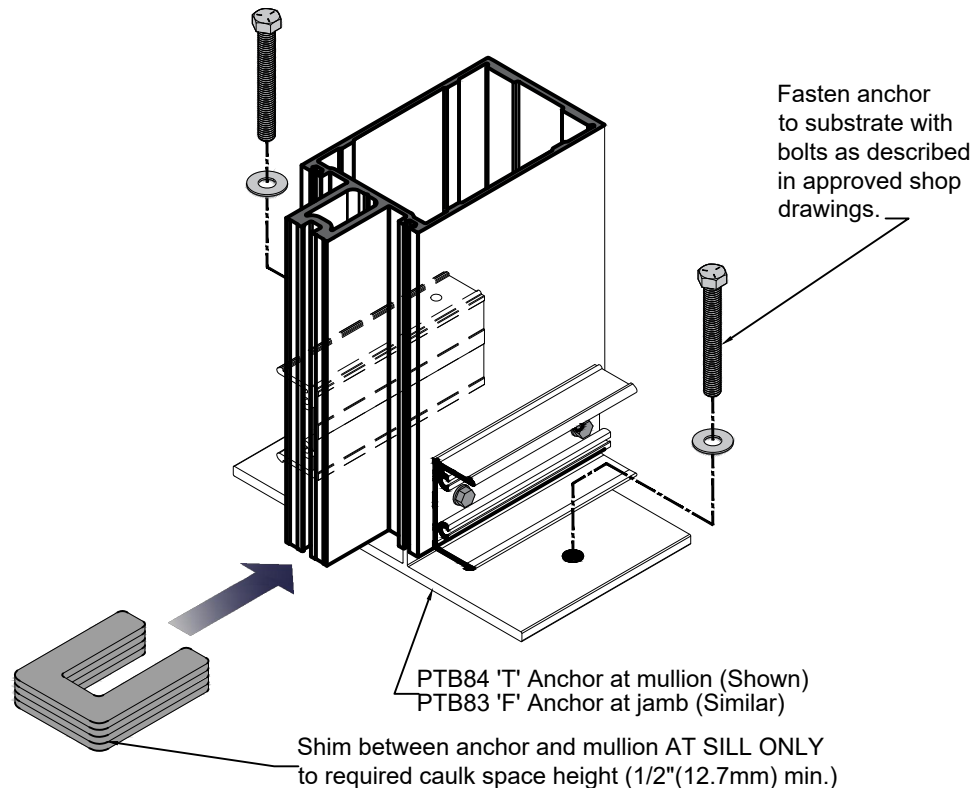

Fig. 33.1

Sill condition shown, head condition similar.

FRAME INSTALLATION

Step 13: Splice Sleeve Attachment

- A. Consult approved shop drawings for number and size of fasteners required to attach the splice sleeve to the verticals.
- B. Drill holes on both sides of the lower vertical in the locations shown on the approved shop drawings.
NOTE: Figure 34.1 shows typical hole pattern.
- C. Slide the splice sleeve into the upper vertical mullion. Tape the sleeve into position temporarily until verticals are erected. See Fig. 34.2.
- D. After the lower and upper verticals are erected, remove the tape holding the splice sleeve and slide into place, securing to the lower mullion as shown on approved shop drawings. See Fig. 34.3.
- E. Apply bond breaker tape to the face of the splice sleeve between the lower and upper verticals, returning back 1" (25.4mm) on each side.
- F. Apply sealant over bond breaker tape at joint. Tool sealant. See Fig. 34.4.

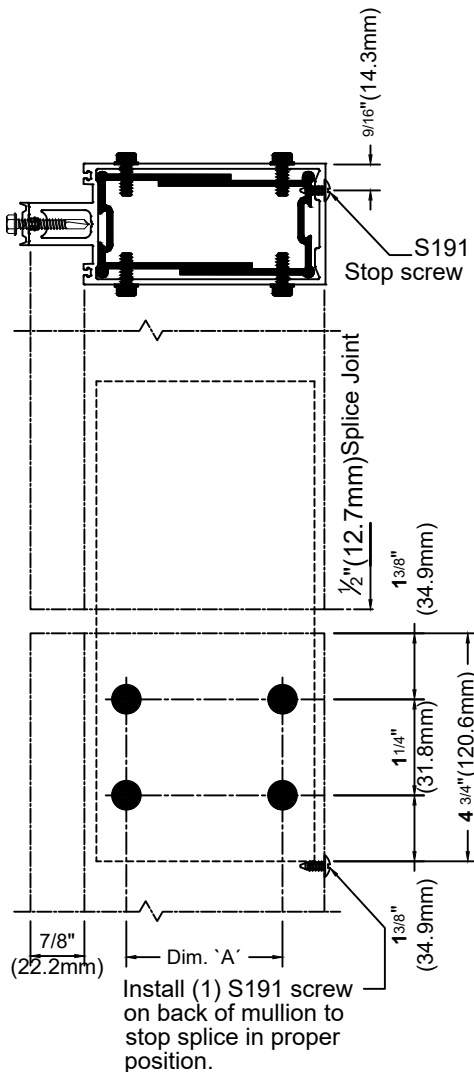
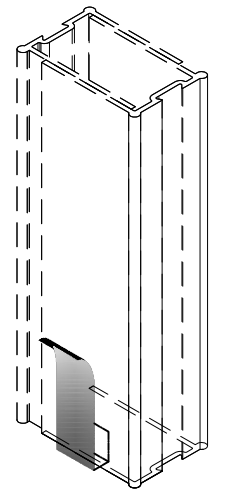

Fig. 34.1



Slide splice sleeve assembly into bottom of upper mullion and tape in place.

Fig. 34.2

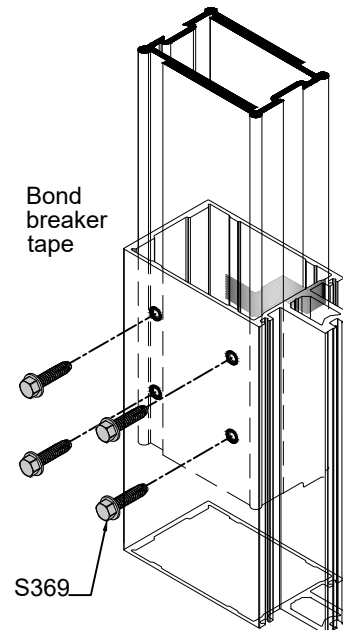

Fig. 34.3

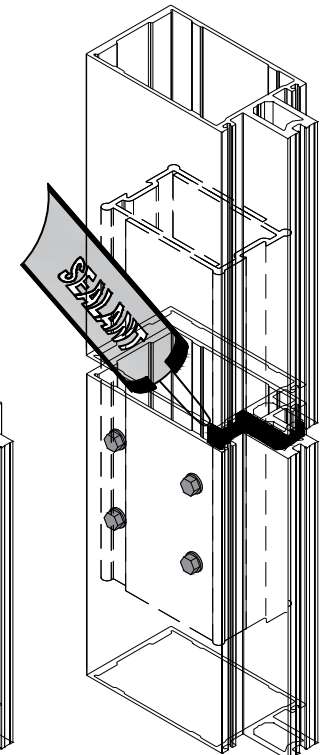

Fig. 34.4

NOTE:
Flat head screws may be used in vision areas.

FRAME FABRICATION

Step 14: Attach Horizontals to Shear Blocks and Anchor Clips

- A. Seal shear block prior to installing the horizontal member. See Fig. 35.2.
- B. Seal the ends of the horizontal back member and attach to the shear block using S270 screws. Seal the heads of the screws.
- C. Tool sealant at the horizontal/vertical intersection. See Fig. 35.3.

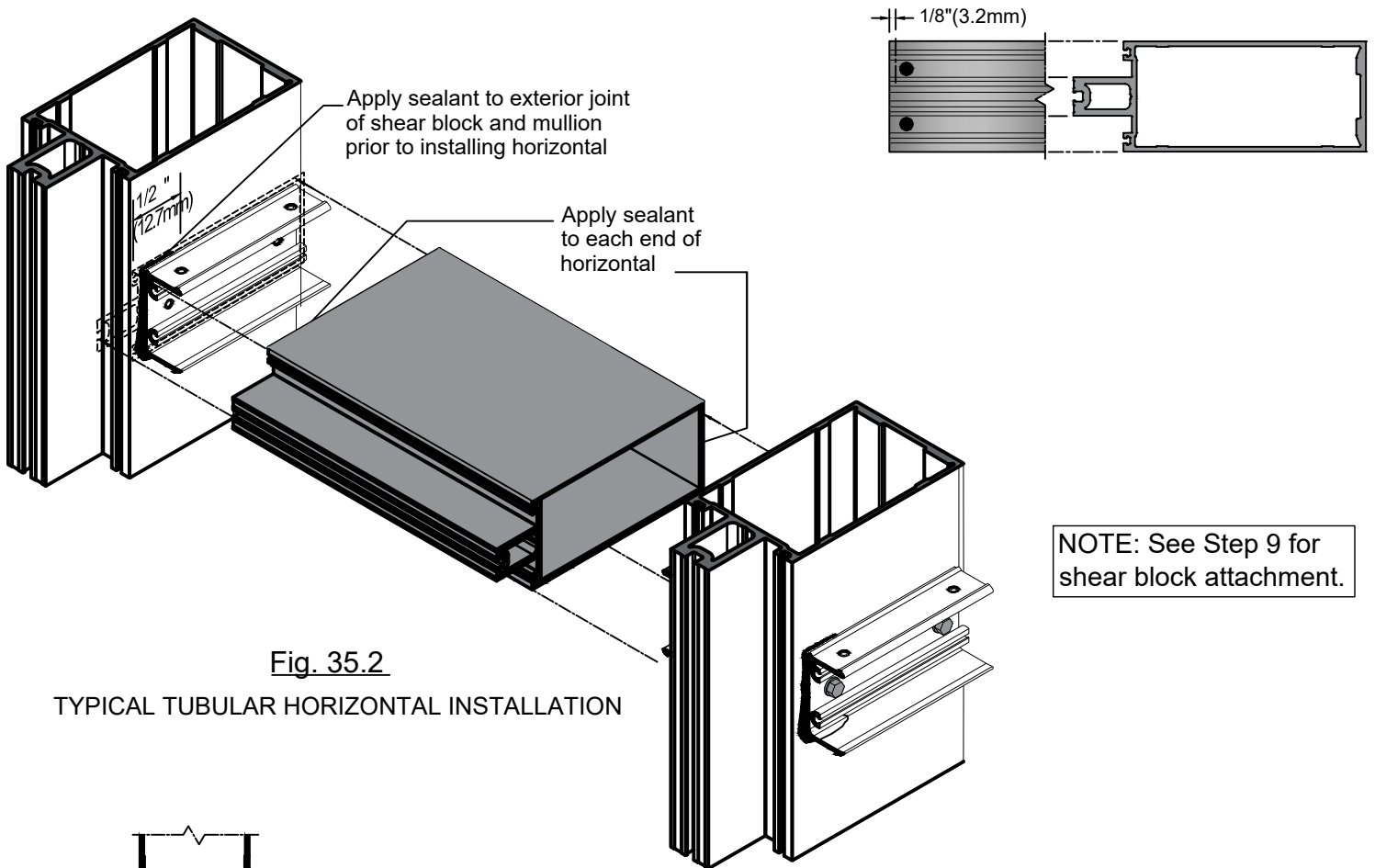

Fig. 35.2

TYPICAL TUBULAR HORIZONTAL INSTALLATION

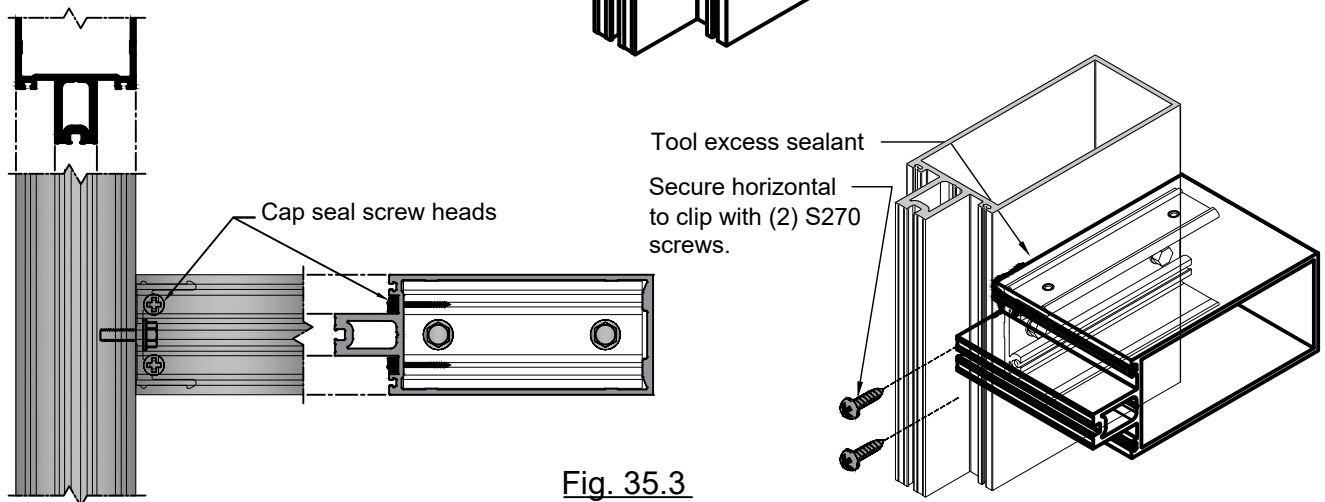
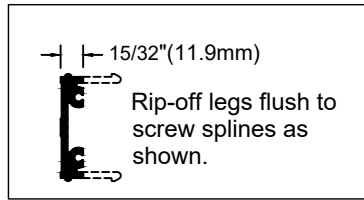

Fig. 35.3

FRAME INSTALLATION

Step 14: Attach Horizontals to Shear Blocks and Anchor Clips (Continued)

LAST BAY TUBULAR HORIZONTAL INSTALLATION



NOTE: See Step 9 for shear block attachment.

MODIFY SHEAR BLOCK
for last bay installation of tubular horizontals

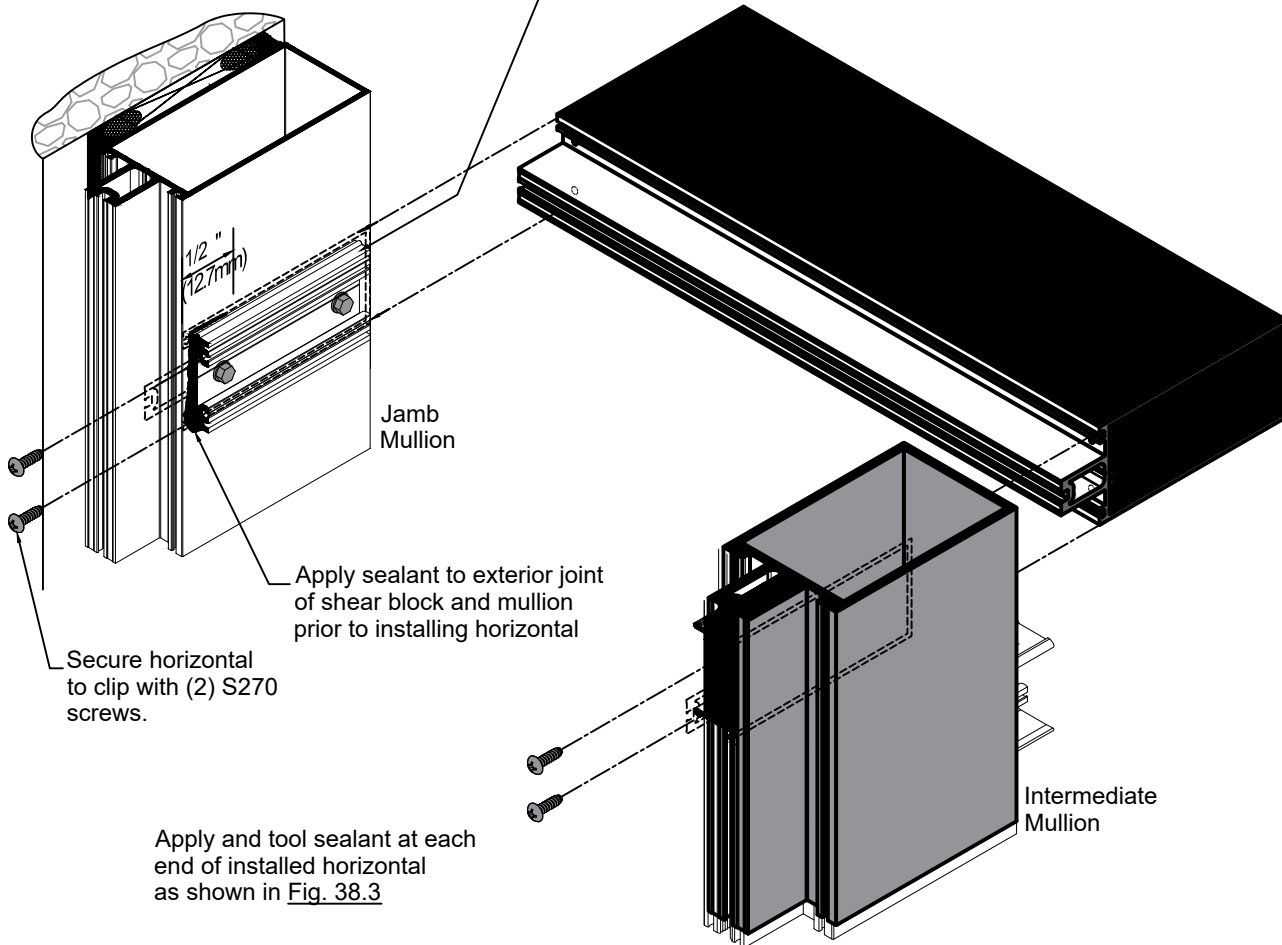
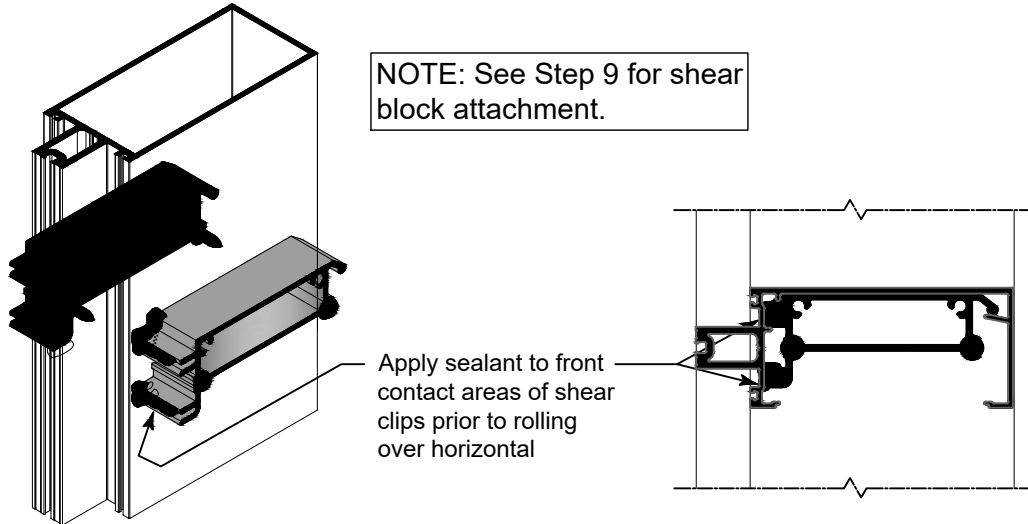

Fig. 36.1

FRAME FABRICATION

Step 14: Attach Horizontals to Shear Blocks and Anchor Clips (Continued)

E. When roll-over horizontal is used, seal face of clip, horizontal ends and screw heads.
See Fig. 37.1, Fig. 37.2 and Fig. 37.3.



Shear Clip for Open Back Horizontals

Fig. 37.1

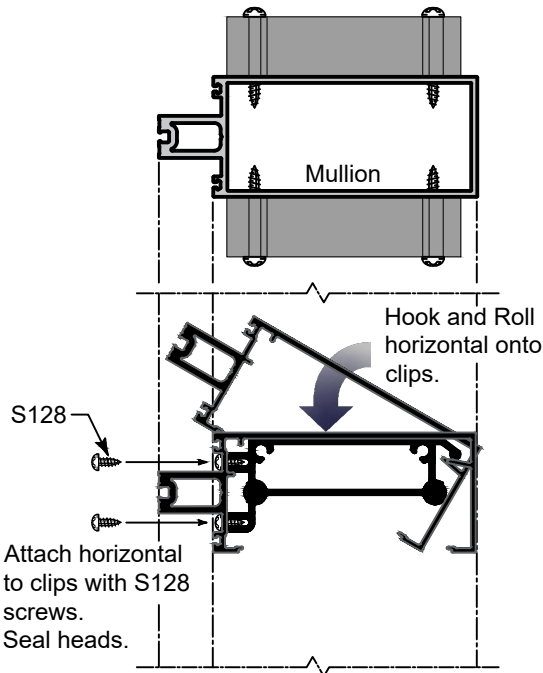
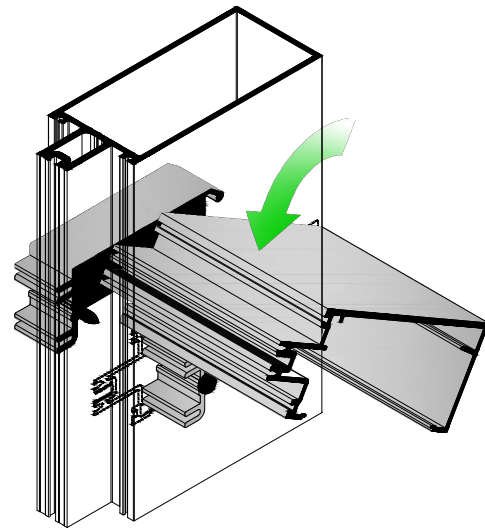

Fig. 37.2



Shear Clip for Open Back Horizontals

Fig. 37.3

FRAME INSTALLATION

Step 14: Attach Horizontals to Shear Blocks and Anchor Clips (Continued)

F. When PTB120 thermal pressure plates are used, install E3192 pocket filler into perimeter members
When P633 polyamide pressure plates are used, install E3192 pocket filler into perimeter members.
See Fig. 38.1 and Fig. 38.2.

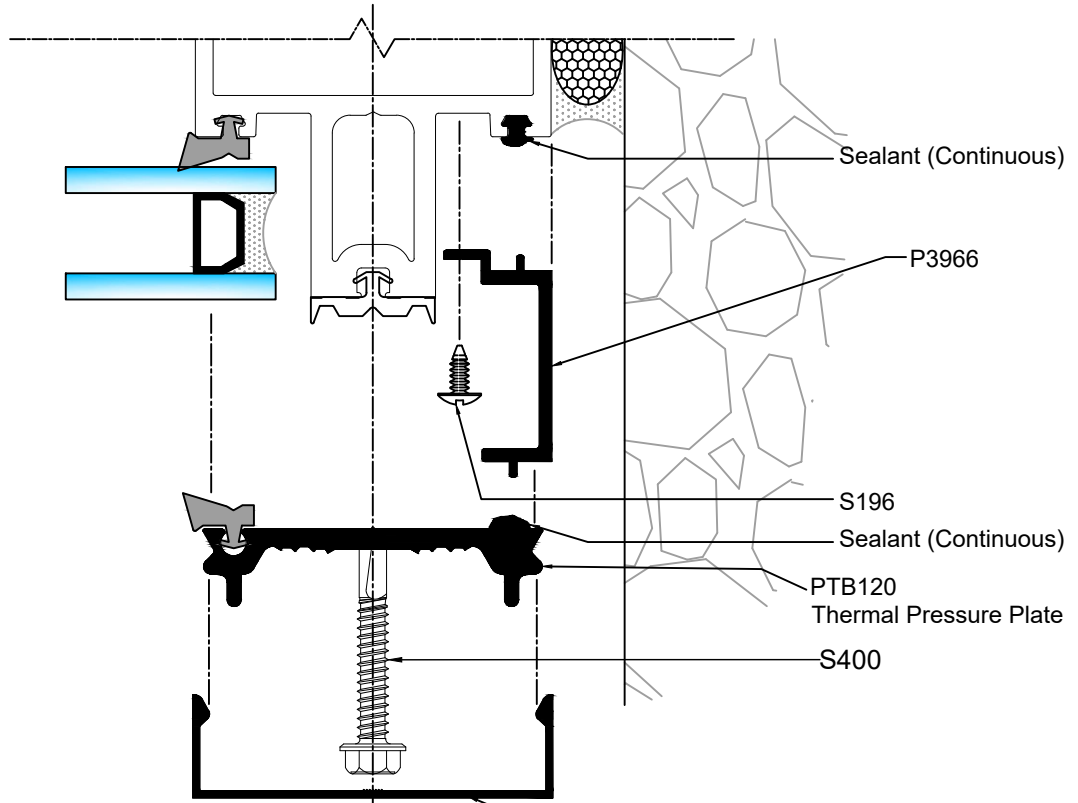

Fig. 38.1

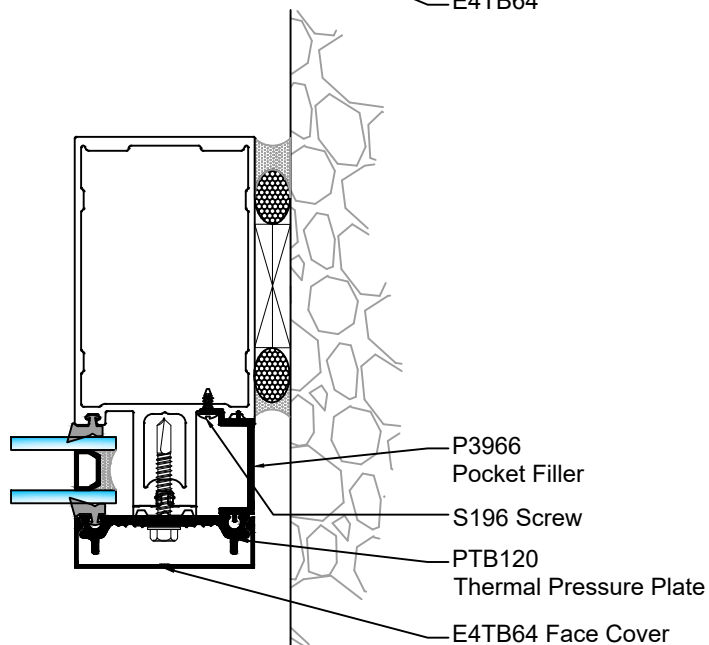

Fig. 38.2

JAMB at ALTERNATE PRESSURE BAR

FRAME INSTALLATION

Step 15: Install Water Dams

- A. Seal the end of the horizontal member across the vertical member. This sealant should be applied liberally.
- B. Push the PTB93 water dam into the void between the horizontal member and the vertical tongue. This is a pressure fit; the water dam should be level with the top of the horizontal tongue.
- C. Seal over the top of the PTB93 onto the horizontal tongue, damming the end of the horizontals.
THIS IS A CRITICAL SEAL.
- D. For vertical SSG applications, follow the same sealing procedures as with a captured system noted above.
- E. When using open back perimeter extrusions (eg E4TB245) stack two PTB93 water dams to seal the ends of the extrusion and form a backer for the perimeter seal. Seal between the PTB93 water dams.

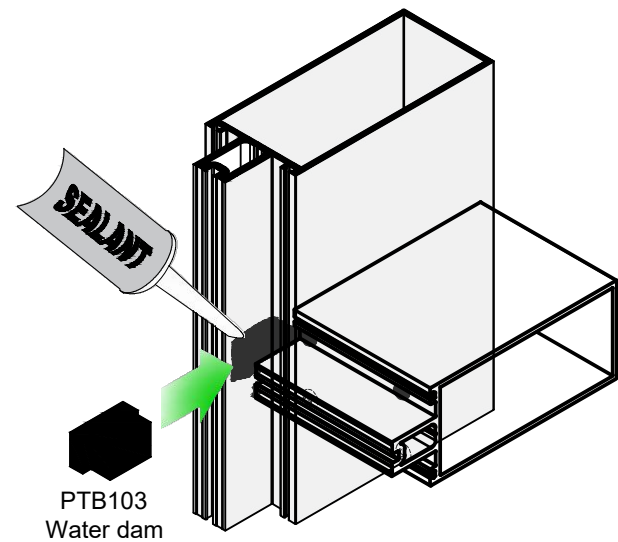
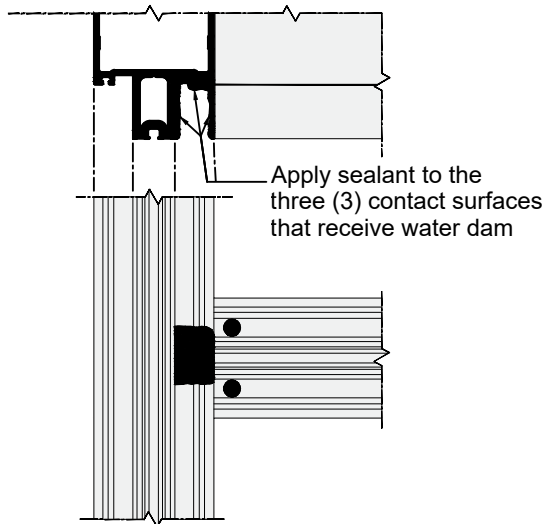

Fig. 39.1

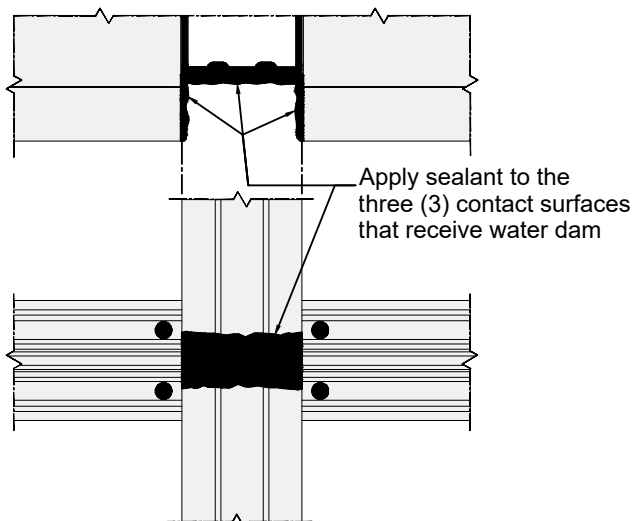

Fig. 39.2

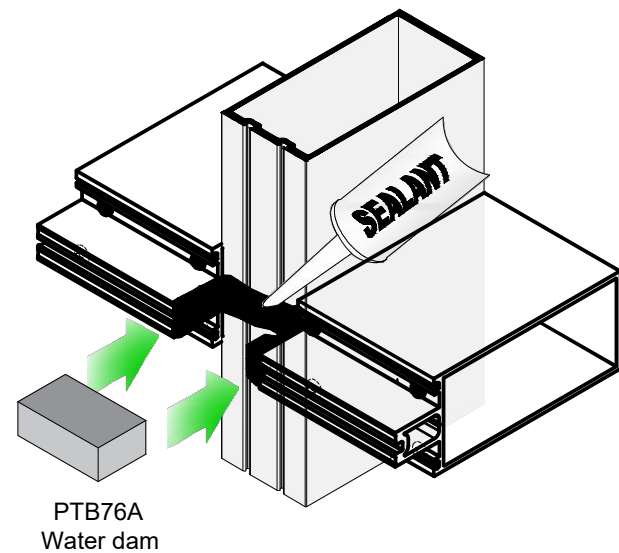

Fig. 39.3

FRAME INSTALLATION

Step 15: Install Water Dams (Continued)

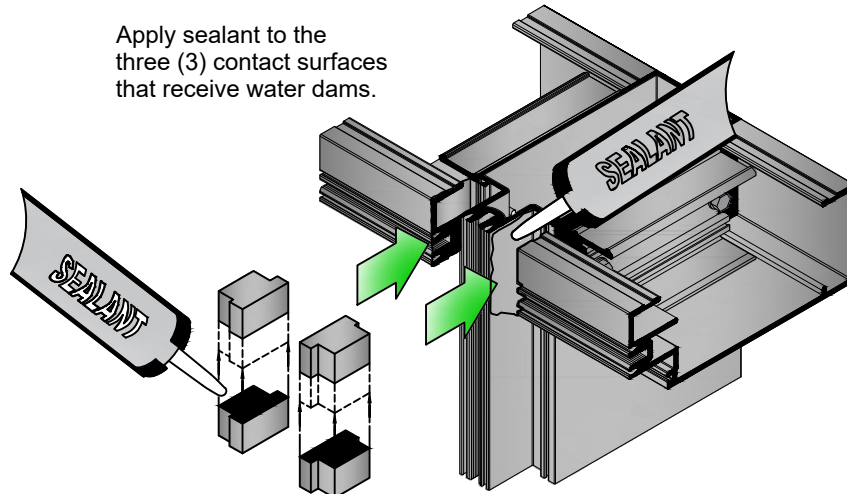

Fig. 40.1

Step 16: Seal Perimeter of Installation

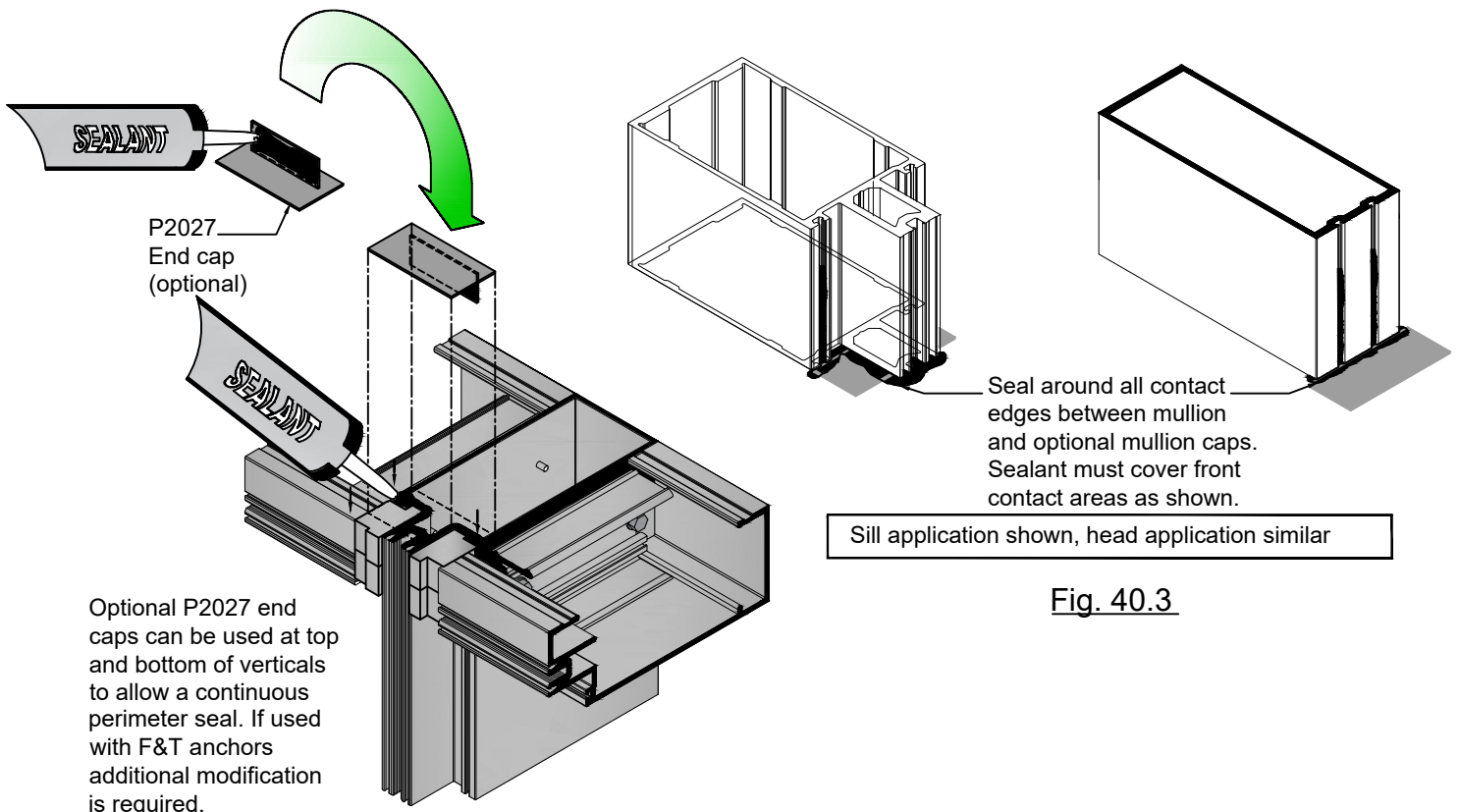

Fig. 40.2

Fig. 40.3

FRAME INSTALLATION

Step 16: Seal Perimeter of Installation (Continued)

- A. Insert backer rod into the gap between the building substrate and curtain wall frame.
- B. Apply sealant around the perimeter of the frame and tool the sealant. See Fig. 41.1 and Fig. 41.2.

NOTE: When using fiberglass pressure plates, install perimeter seal as shown in Fig. 42.1 and Fig. 42.2.

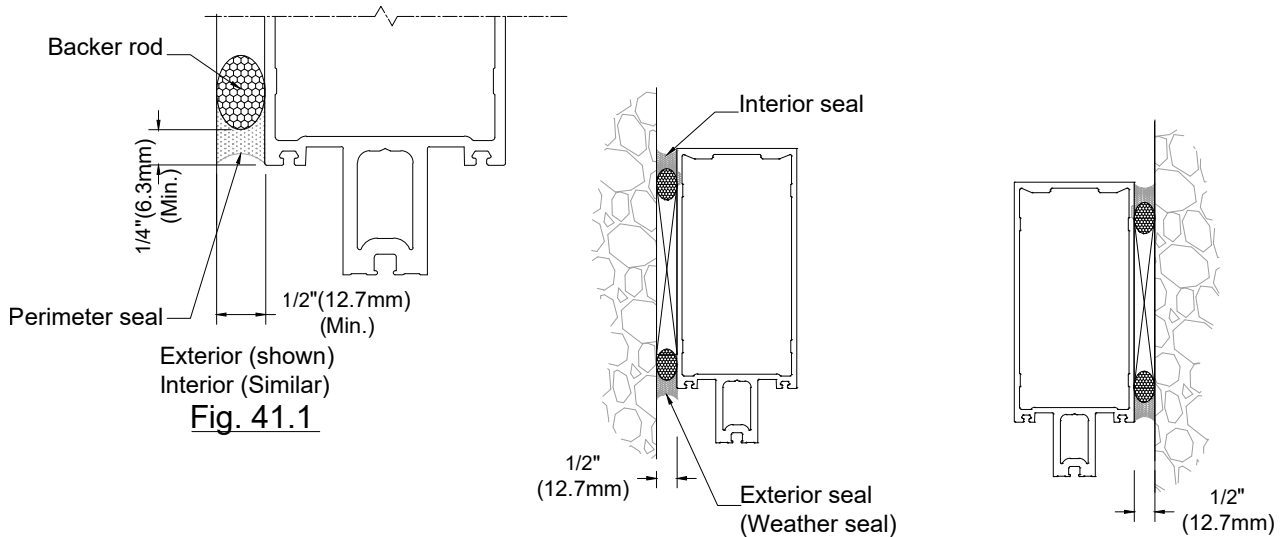

NOTE: Exterior and Interior perimeter seals must run continuous full perimeter of framing. When using tubular head and sill members, the vertical tongue can be notched to make the perimeter seal easier. See FIG. 41.3

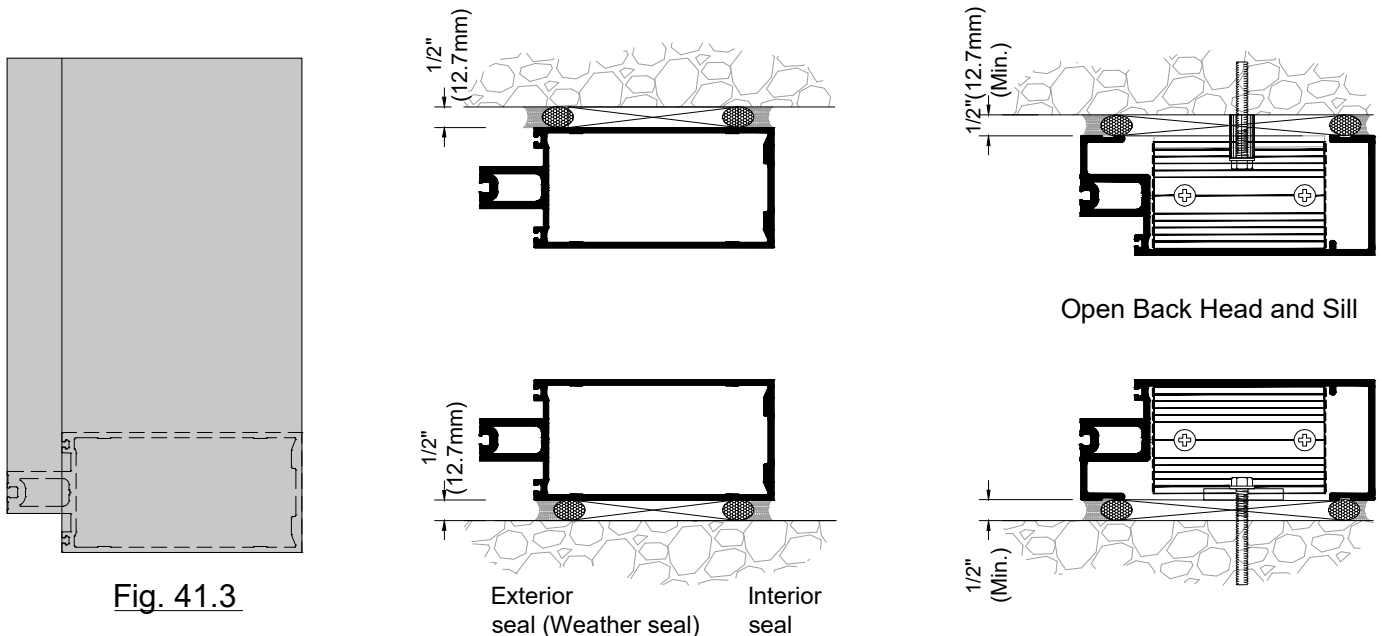

Mullion end cap installation

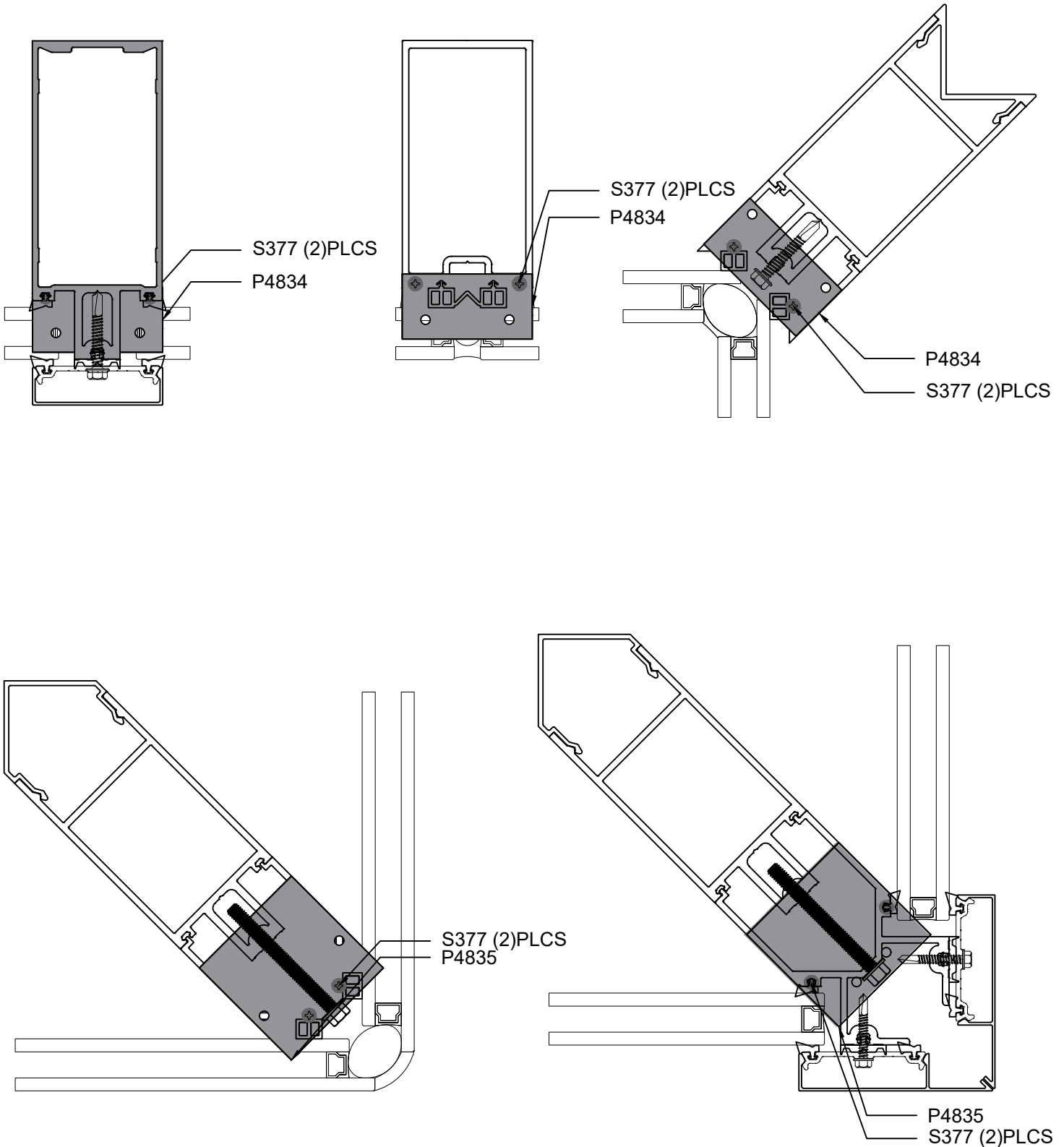

GLAZING

Step 17: Glazing Preparation

- A. Remove any debris from the glazing pockets.
- B. Trim excess silicone from edges of glazing units to allow for maximum glazing clearance.

Glazing pockets are designed to accept a variety of infill thicknesses. Refer to our online System Glazing Chart for a full list of glazing size options for this system:

http://www.tubeliteinc.com/wp-content/uploads/2014/05/Tubelite_Glazing_Chart.pdf

Step 18: Install Gaskets

NOTE: Crowd gaskets toward the center of the member during installation to avoid gaps caused by relaxation of the gasket material.

- A. Install PTB28 gasket into vertical and horizontal pressure plates. See Fig. 42.1. **When PTB28 gasket is used with PTB120 thermal pressure plate, seal in place with 1" of sealant to both ends and every 18"**
- B. Install PTB28 gasket into vertical mullions. See Fig. 42.3 and Fig. 43.1. Vertical mullion gaskets run beyond the horizontals. Run the vertical gasket through the vertical splice joint, setting in fresh sealant at the splice. Notch darts off the gasket as required for proper fit.
- C. Install PTB28 gasket into the horizontals.
- D. Install PTB94 isolator gasket into vertical and horizontal tongues. Run the isolator through the vertical splice joints.
- E. For SSG vertical applications, remove the joining legs on PTB106 SSG spacer gasket. See Fig. 42.2. Install into vertical mullion with equal overlap into each horizontal pocket. See Fig. 43.1.

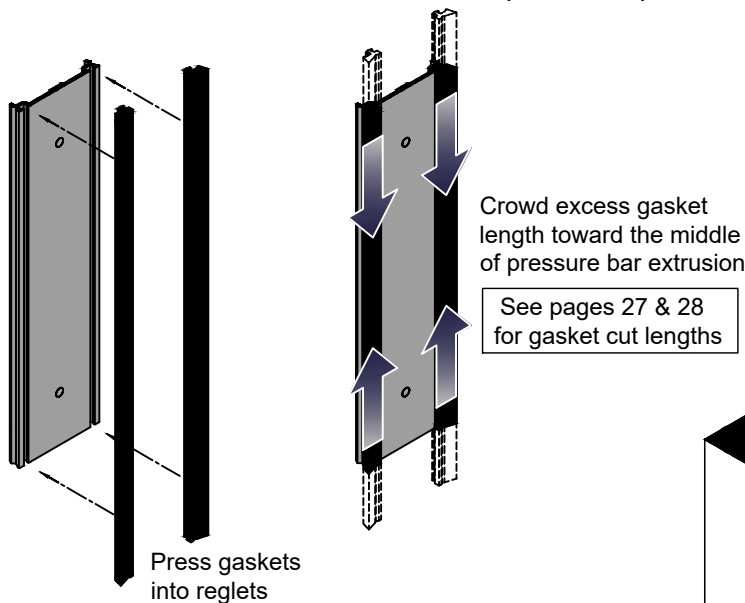

Fig. 42.1

Typical with vertical and horizontal gaskets.

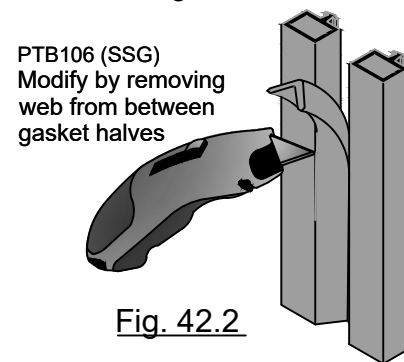

Fig. 42.2

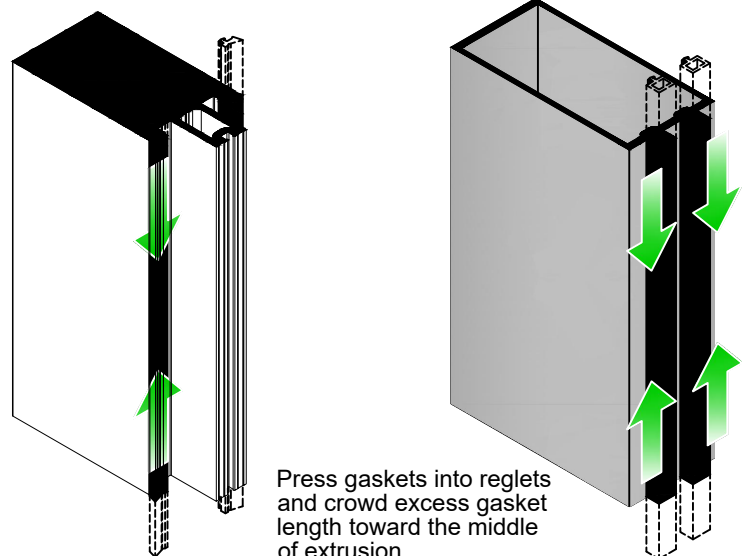

Fig. 42.3

GLAZING

Step 18: Install Gaskets (Continued)

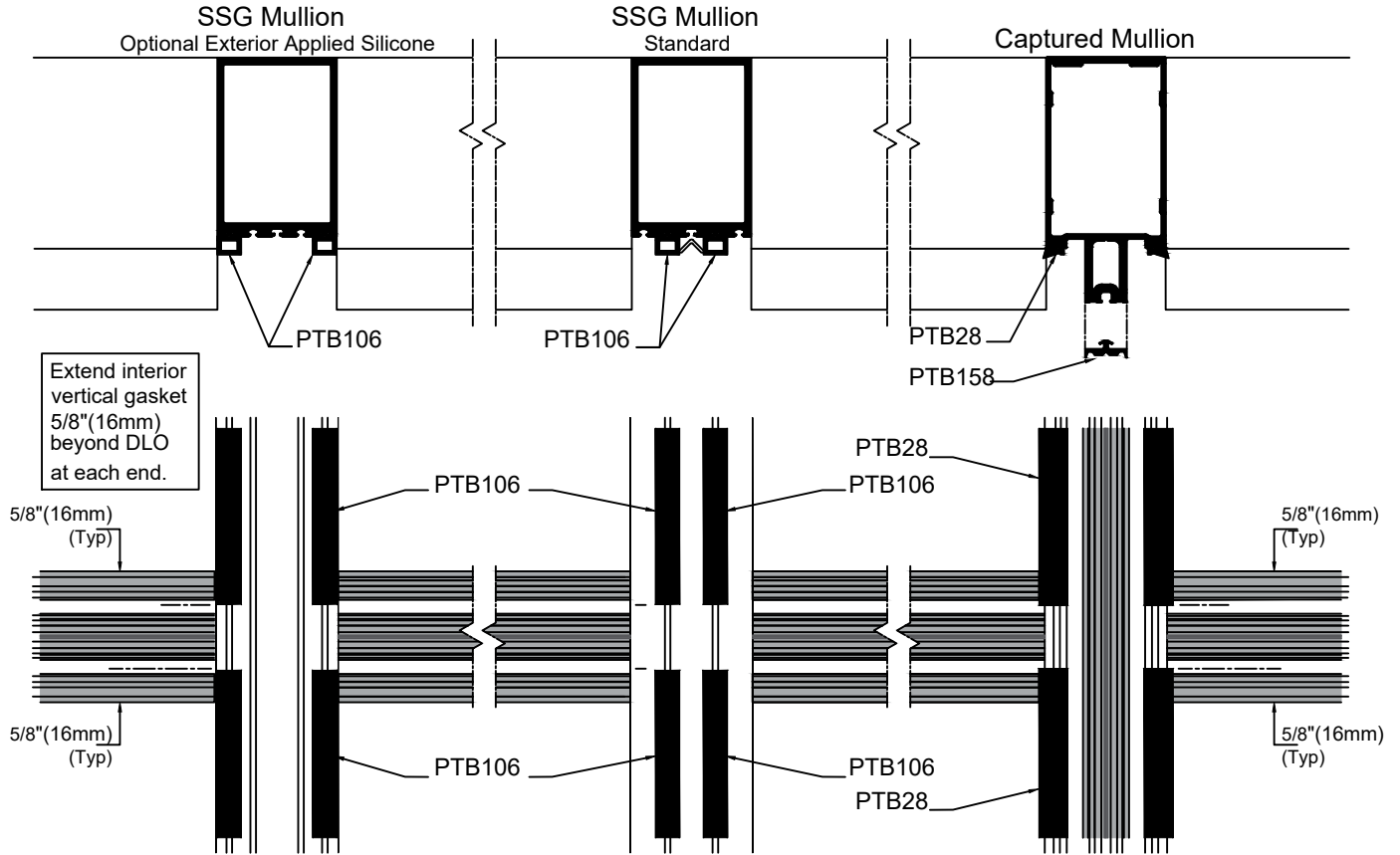

Fig. 43.1

GLAZING

Step 19: Installing Glass

NOTE: Pre-seal gaskets only in the opening to be glazed to avoid sealant curing and contamination before glass is set in place.

- A. Pull interior horizontal gaskets away from vertical gaskets and seal corners where gaskets abut. Release horizontal gasket back to its original position. See Fig. 44.1.
- B. Install two P946 setting blocks for 1"(25.4mm) glass at quarter points or as indicated on approved shop drawings.
Note: Consult glass manufacturer for correct length and location for glass size over 40 sq.ft.(3.716 sq.m.)
- C. Install glass onto setting blocks, positioning glass for proper glass bite into vertical mullions. Make sure the glass is firmly against interior gaskets before installing temporary glazing clips or pressure plates.
- D. Make sure sealant is not bridging or blocking the water area between the edges of the glass and the framing system.
- E. Hold the glass in place using P1194 temporary glazing clips. Locate clips near each corner of the glass and at mid points. Temporary glazing retainers are intended for short term use only. Additional retainers or full length pressure plates may be required if high wind load pressures are anticipated before the installation is complete.
- F. For SSG vertical applications, hold the glass in place at the vertical with P1194 temporary glazing clips and a 1/4" x 2" TEK screw. Tape off side of SSG vertical and glass prior to applying structural silicone. After structural silicone has cured per silicone manufacturer's recommendations, remove P1194 temporary glazing clips, seal hole in the SSG vertical from the P1194 screw and apply a weather seal between the lites of glass.

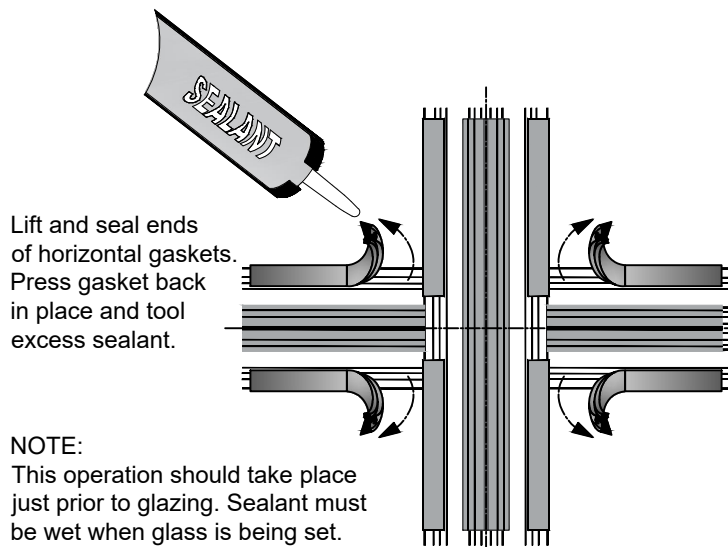

Fig. 44.1

GLAZING

Step 19: Installing Glass (Continued)

- B. Install two P946 setting blocks for 1”(25.4mm) or P948 setting blocks for 1/4”(6.3mm) glass at quarter points or as indicated on approved shop drawings.
 Note: Consult glass manufacturer for correct length and location for glass size over 40 sq.ft.(3.716 sq.m.)
- C. Install glass onto setting blocks, positioning glass for proper glass bite into vertical mullions. Make sure the glass is firmly against interior gaskets before installing temporary glazing clips or pressure plates.
- D. Make sure sealant is not bridging or blocking the water area between the edges of the glass and the framing system.

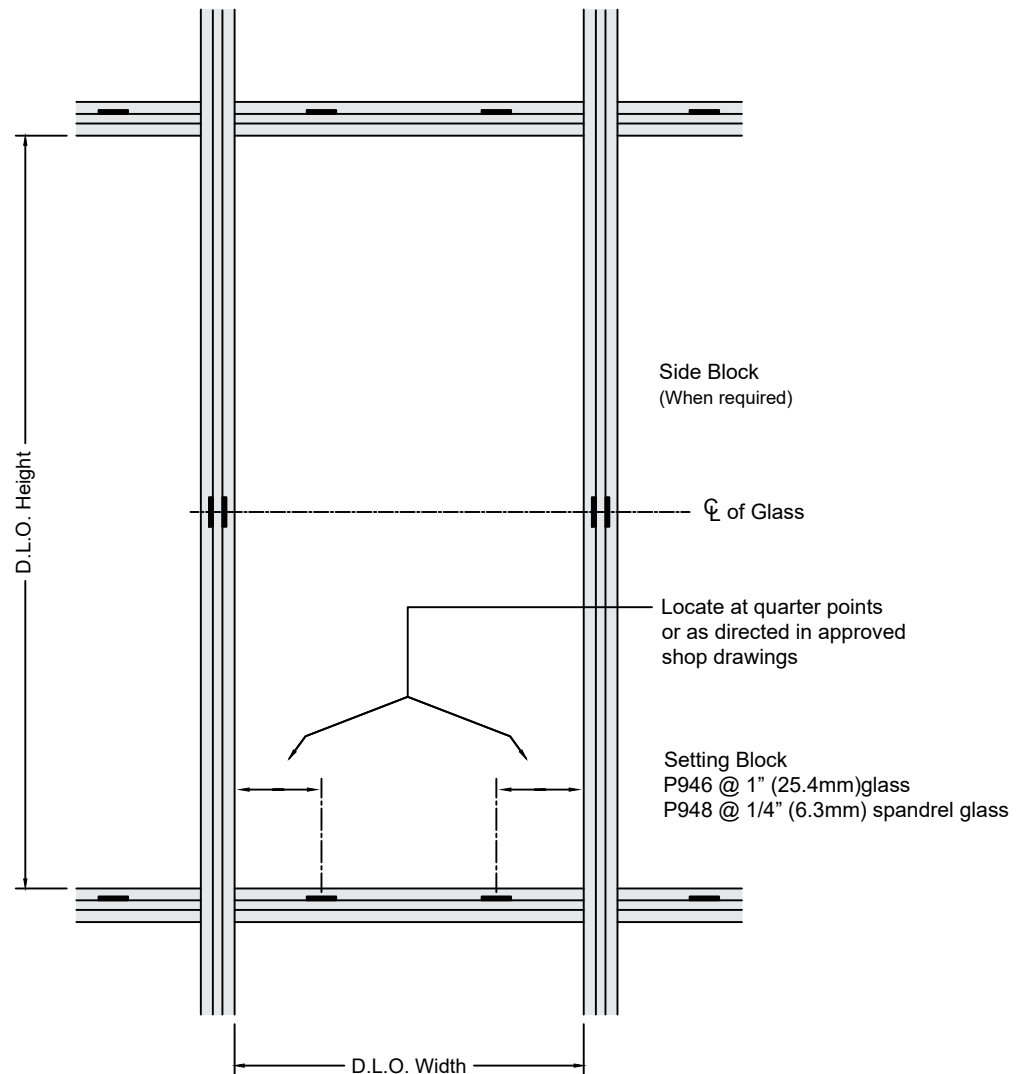
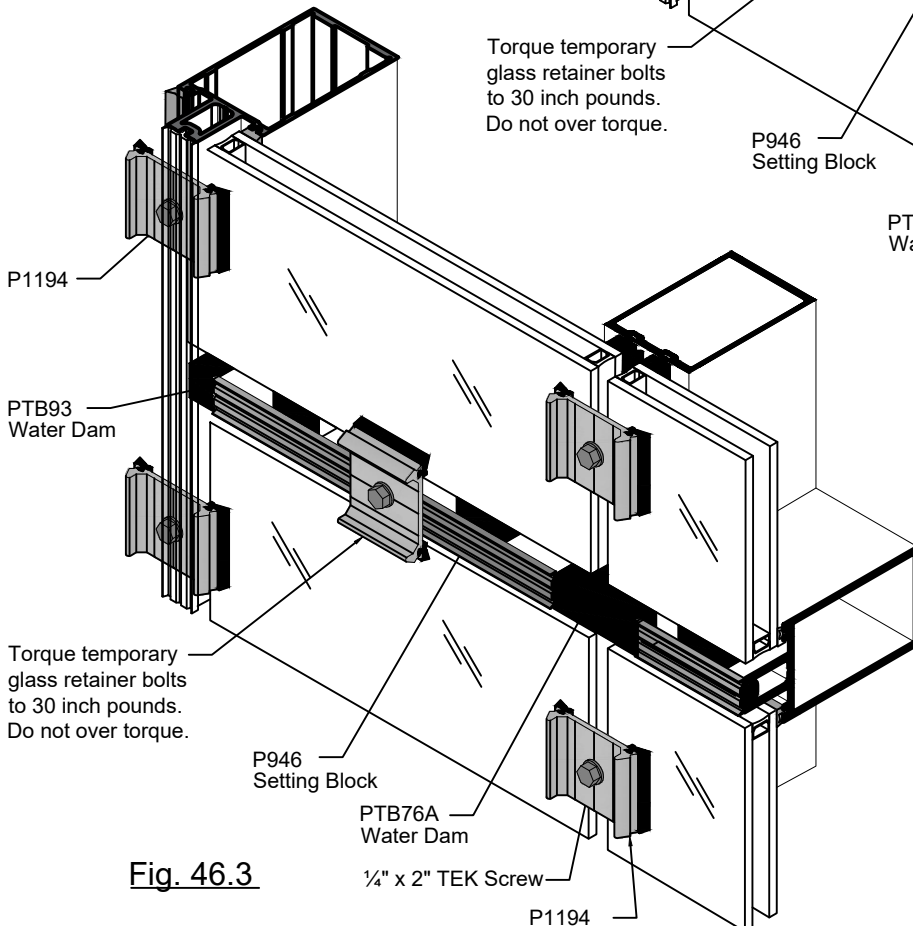
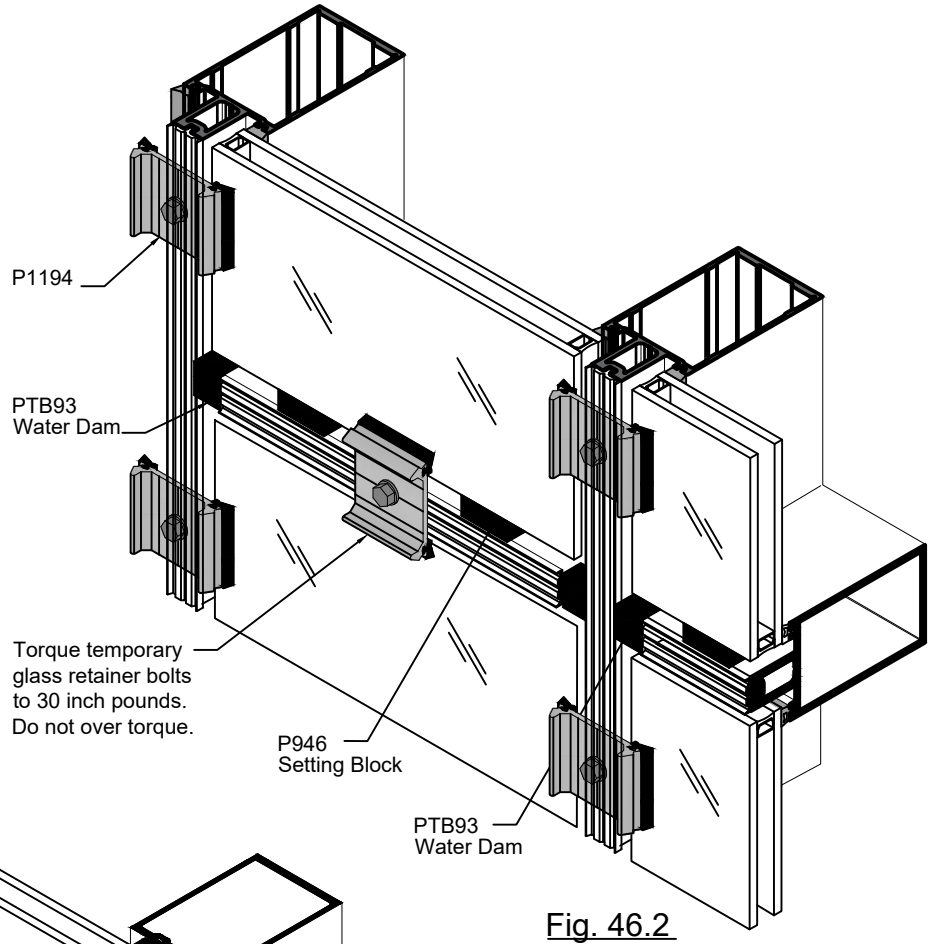
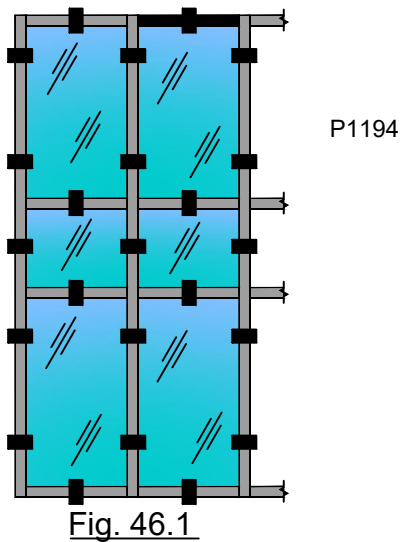

Fig. 45.1

GLAZING

Step 19: Installing Glass (Continued)

E. Hold the glass in place using P1194 temporary glazing clips. Locate clips near each corner of the glass and at mid points. Temporary glazing retainers are intended for short term use only. Additional retainers or full length pressure plates may be required if high wind load pressures are anticipated before the installation is complete.



GLAZING

Step 19: Installing Glass (Continued)

F. For SSG vertical applications, where structural silicone is applied from interior, hold the glass in place at the vertical with P1194 temporary glazing clips and a 1/4" x 2" TEK screw. Tape off side of SSG vertical and glass prior to applying structural silicone. After structural silicone has cured per silicone manufacturer's recommendations, remove P1194 temporary glazing clips, seal hole in the SSG vertical from the P1194 screw and apply a weather seal between the lites of glass. See Fig. 47.3 for optional exterior applied structural silicone.

Trim edges of structural silicone area with masking tape for clean lines. Apply silicone and tool.

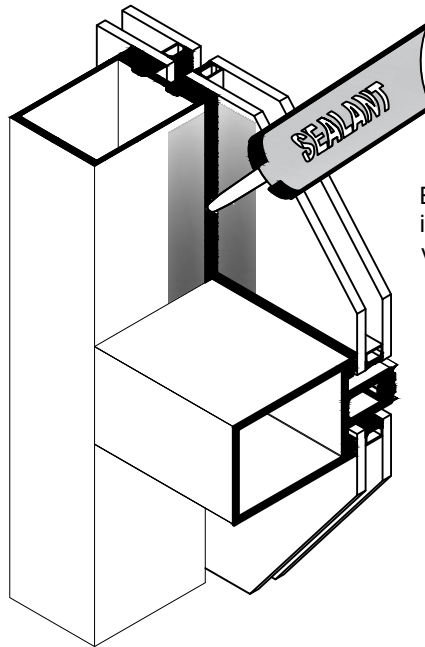

Ensure silicone is injected into voids at horizontal and vertical intersection.

Fig. 47.1

Seal holes from temporary glass retainer then apply weather seal.

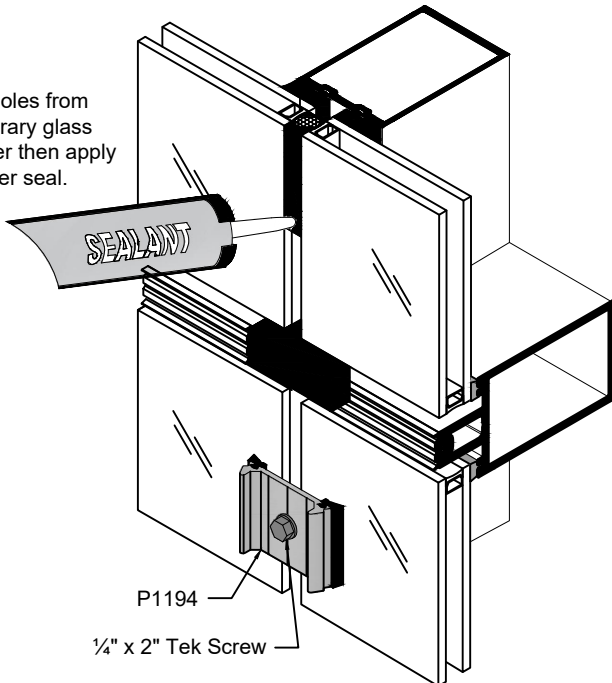

Fig. 47.2

Seal holes from temporary glass retainer then apply weather seal.

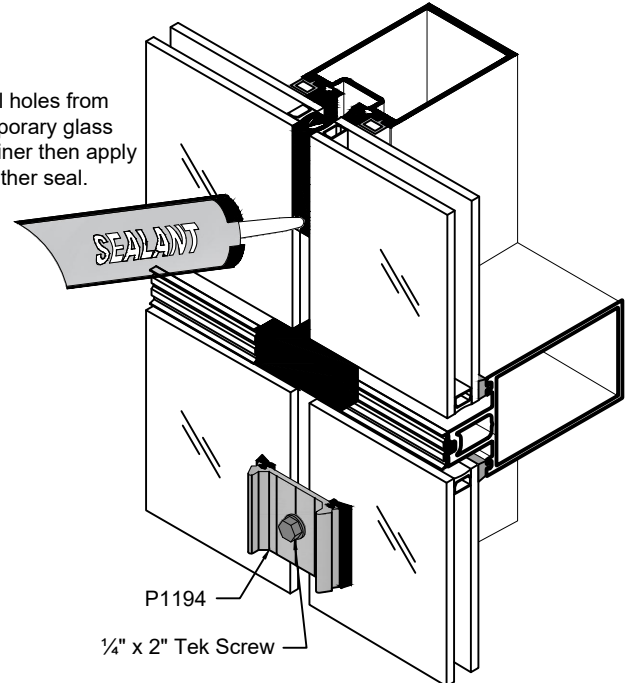

Fig. 47.3

GLAZING

Step 20: Install Pressure Plates and Face Covers

- A. Remove temporary glazing retainers from verticals as required.
- B. Vertical pressure plates must be installed first. Prior to installing, apply sealant to the face of each water dam.
- C. Install the vertical pressure plates using S369 screws.
- D. Remove temporary glazing retainers from horizontals as required.
- E. Install the horizontal pressure plates using S369 screws, ensuring that weep holes are on the top side of the pressure plate.
- F. Ensure there are anchor holes in the pressure plates 2"(50.8mm) max from the ends and 2"(50.8mm) max from each horizontal/vertical intersection to maintain proper compression on the glass.
- G. Torque all pressure plate screws to 60 in-lbs. When using a cordless drill with a torque limiter, check torque periodically against a torque wrench.
- H. Install the vertical face covers using a wood block to protect the face cover.
- I. Seal the horizontal pressure plates to the vertical face covers, tooling the sealant into the joint.
- J. Install the horizontal face covers with equal gaps on each end. Make sure the weep slots in the face cover are pointing down.

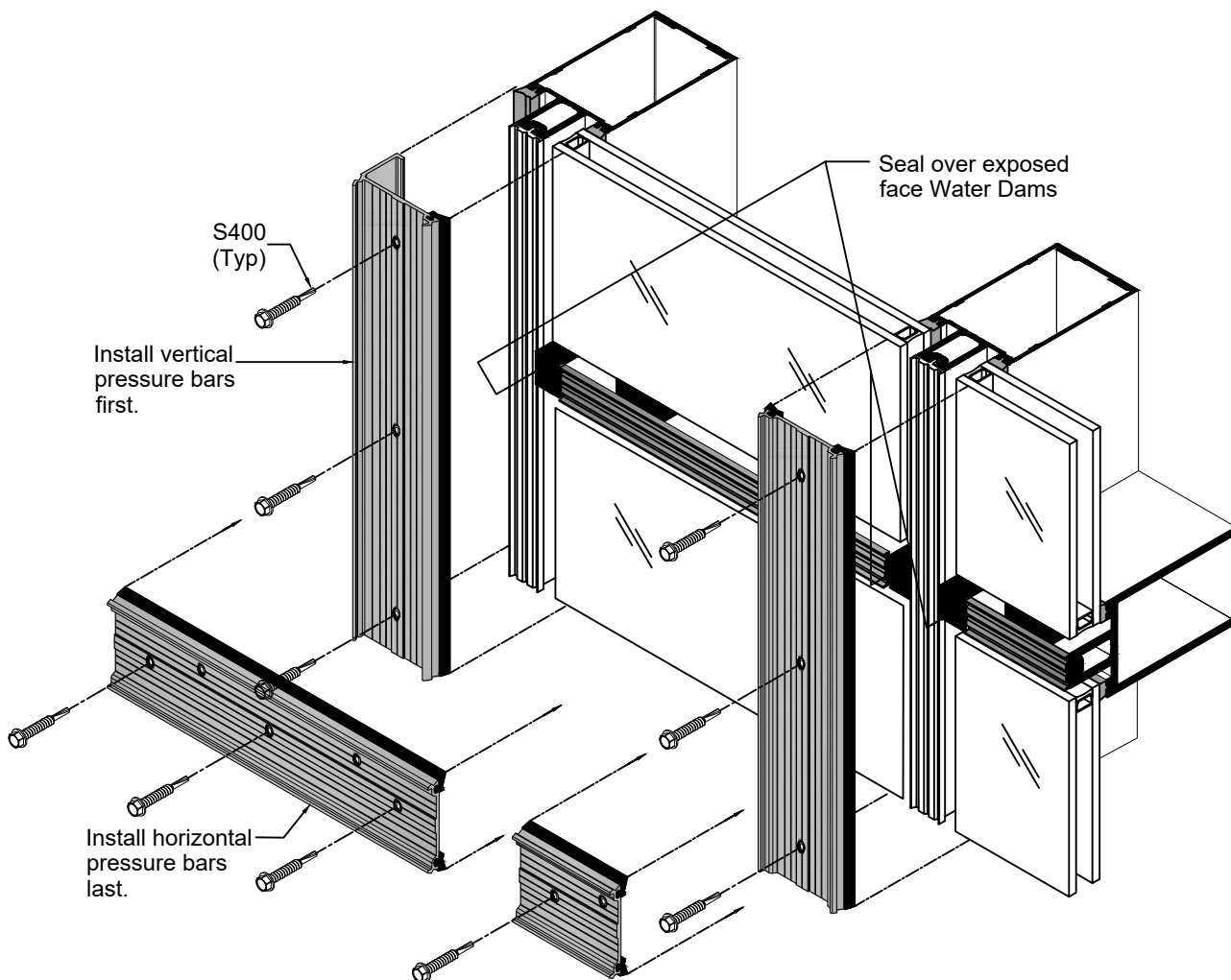
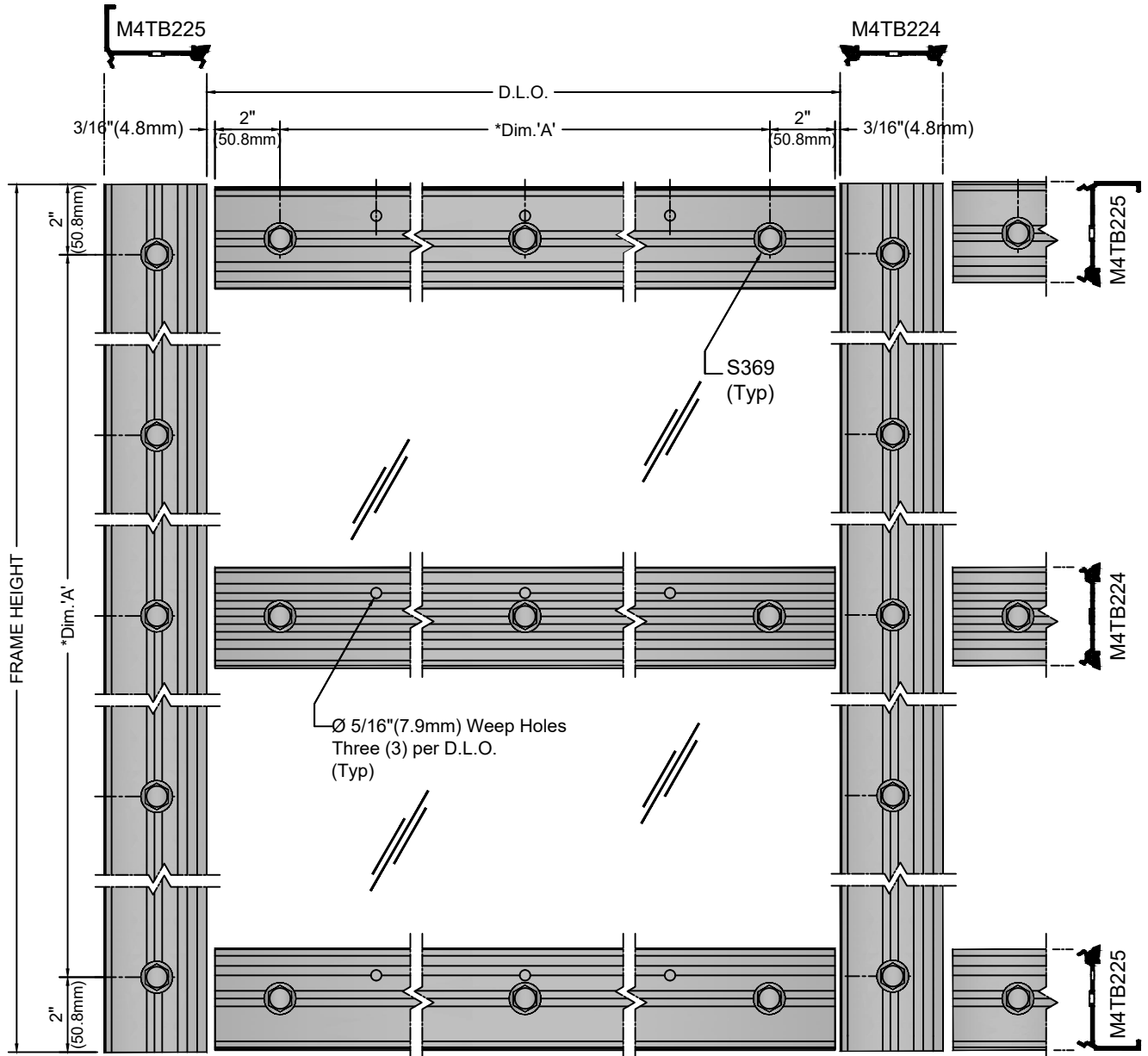

Fig. 48.1

Also see Fig. 49.1 and Fig. 50.1.

GLAZING

Step 20: Install Pressure Plates and Face Covers (Continued)



* See page 27 for pressure plate anchor spacing chart

Fig. 49.1
CAPTURED PRESSURE BAR INSTALLATION

GLAZING

Step 20: Install Pressure Plates and Face Covers (Continued)

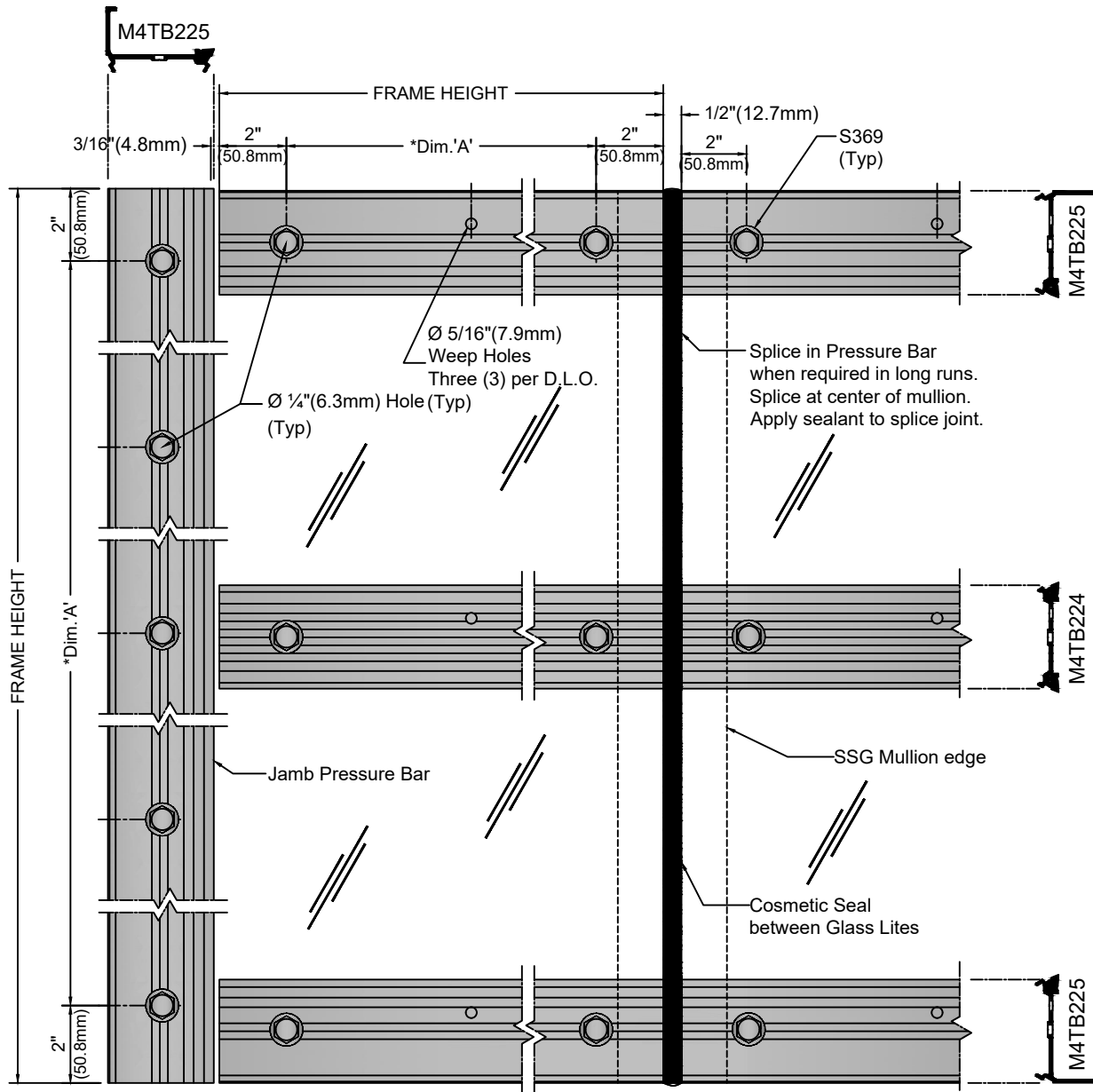

* See page 27 for pressure plate anchor spacing chart

Fig. 50.1
SSG PRESSURE BAR INSTALLATION

GLAZING

Step 20: Install Pressure Plates and Face Covers

H. Install the vertical face covers using a wood block to protect the face cover.

I. Pinning requirements for all pressure plates:

Cover depth less than 1" (25.4mm): Pin to pressure plate as required

Cover depth 2" (50.8mm) or more:

Less than 6 ft (1.83m) long: Pin to pressure plates at center on each side

Greater than 6 ft (1.83 m) long: Pin to pressure plates at each end and 3 ft (0.914m) O.C.

Building specific conditions may require spacing different than this. Consult Tubelite Engineering for recommendations.

J. Seal the horizontal pressure plates to the vertical face covers, tooling the sealant into the joint.

K. Install the horizontal face covers with equal gaps on each end. Make sure the weep holes in the face cover are pointing down.

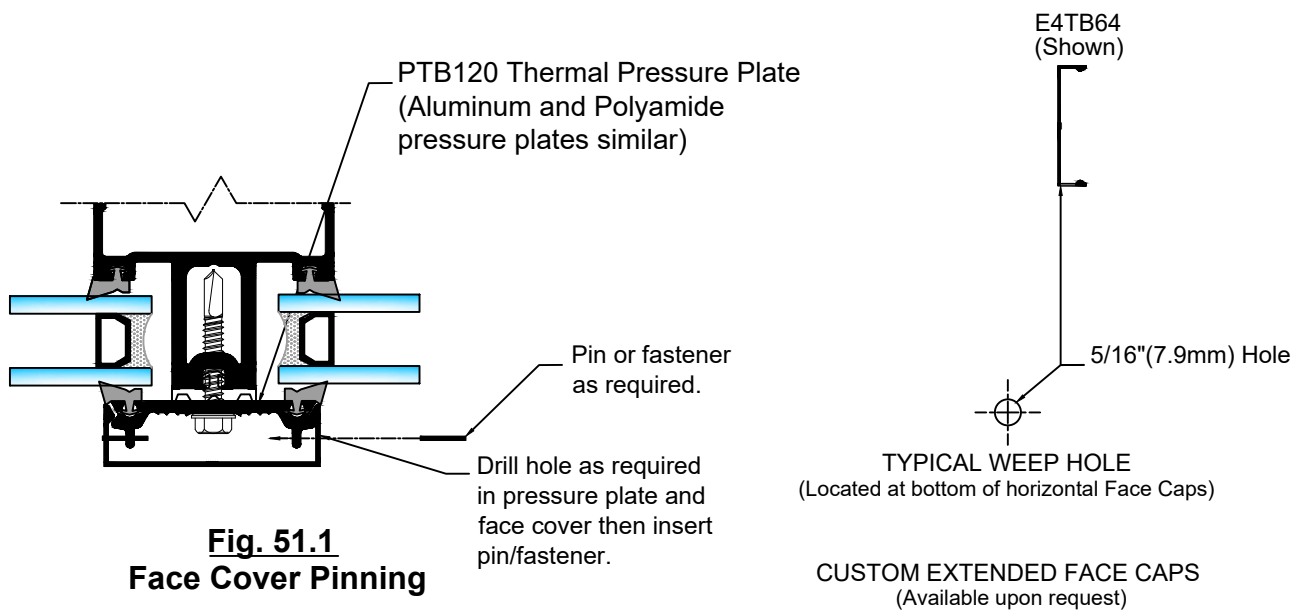

Fig. 51.1
Face Cover Pinning

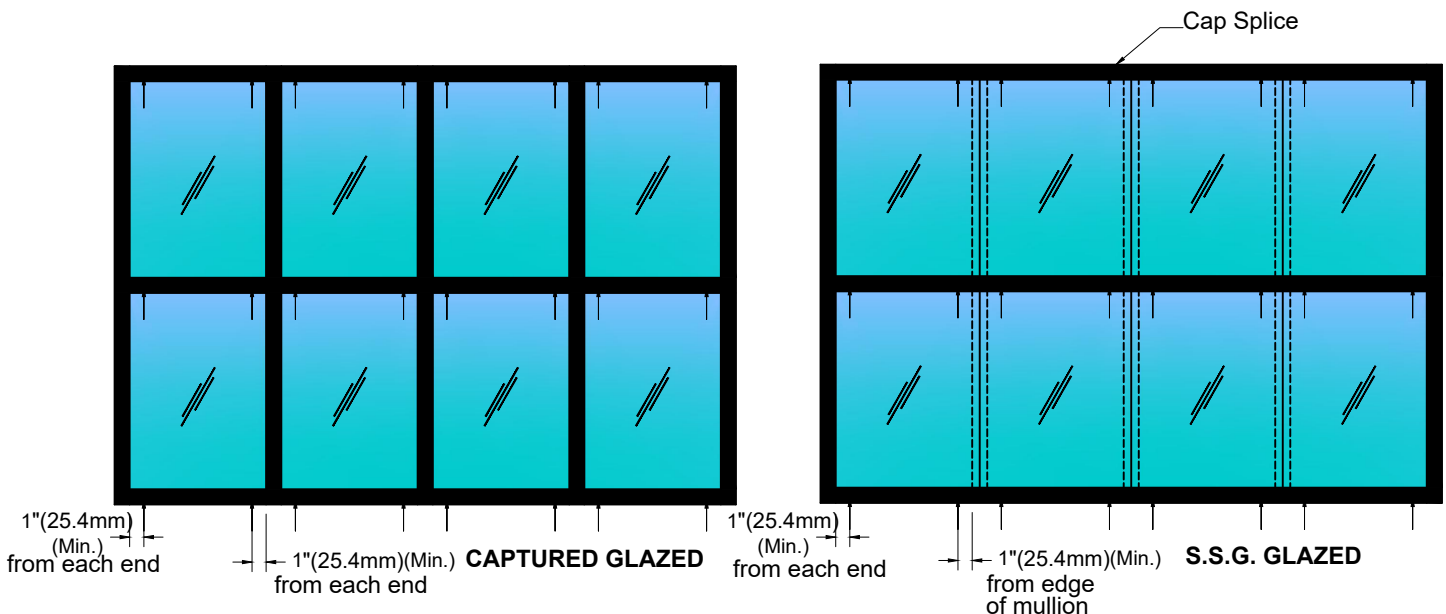

Fig. 51.2

GLAZING

Step 20: Install Pressure Plates and Face Covers (Continued)

Seal horizontal pressure bar end gaps.

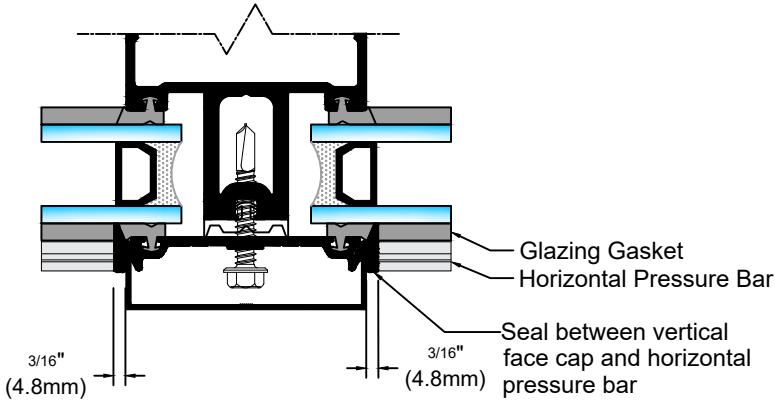

Fig. 52.1

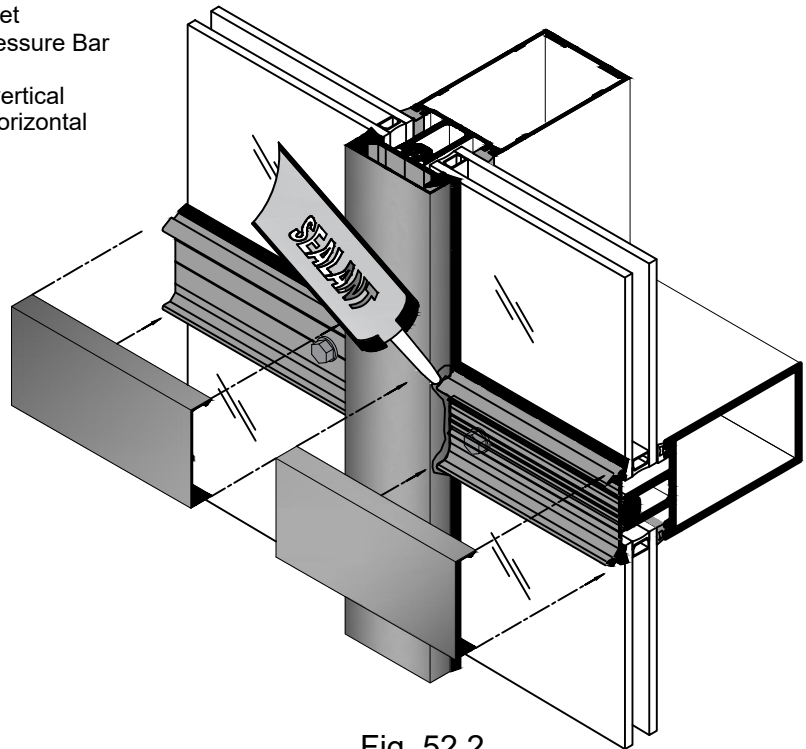

Fig. 52.2

GLAZING

Step 20: Install Pressure Plates and Face Covers (Continued)

Pressure Bar and Face Cap at multi-span mullion splice.

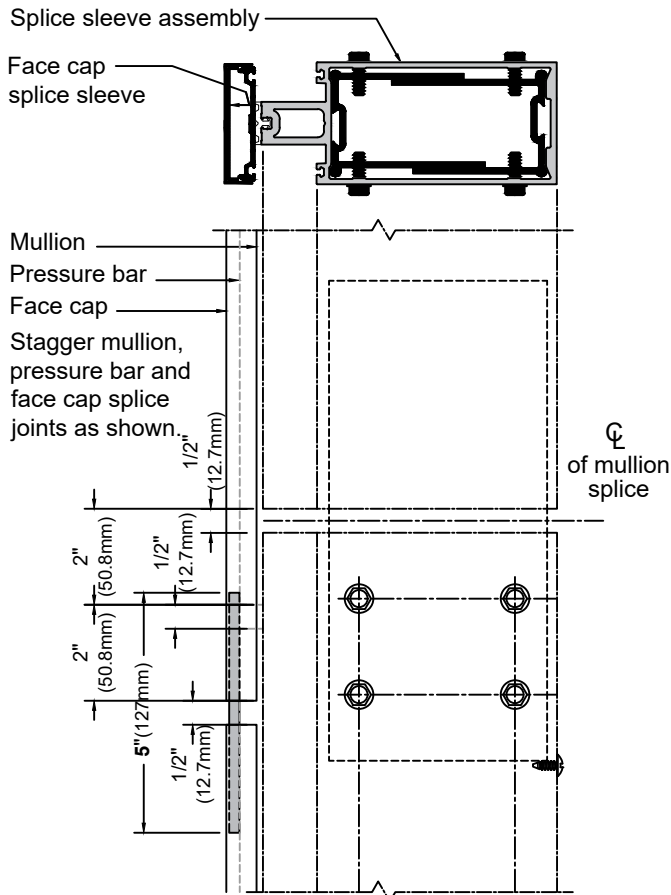

Fig. 53.1

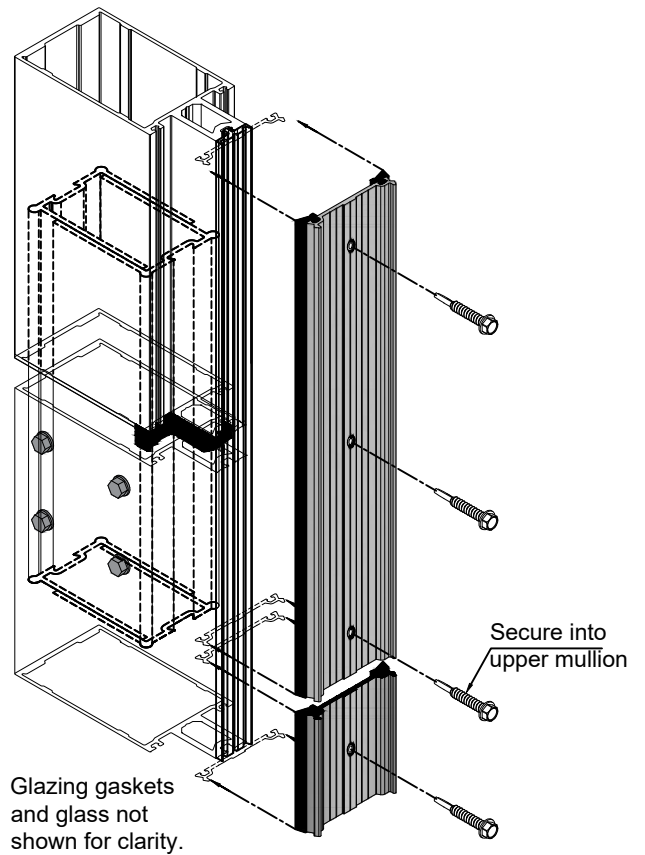

Fig. 53.2

See Step 13 for mullion splice procedure.

GLAZING

Step 20: Install Pressure Plates and Face Covers (Continued)

Pressure Bar and Face Cap at multi-span mullion splice.

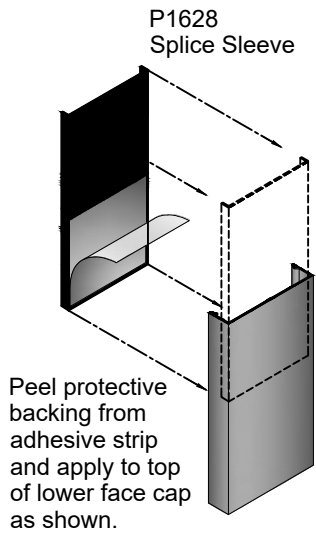

Fig. 54.1

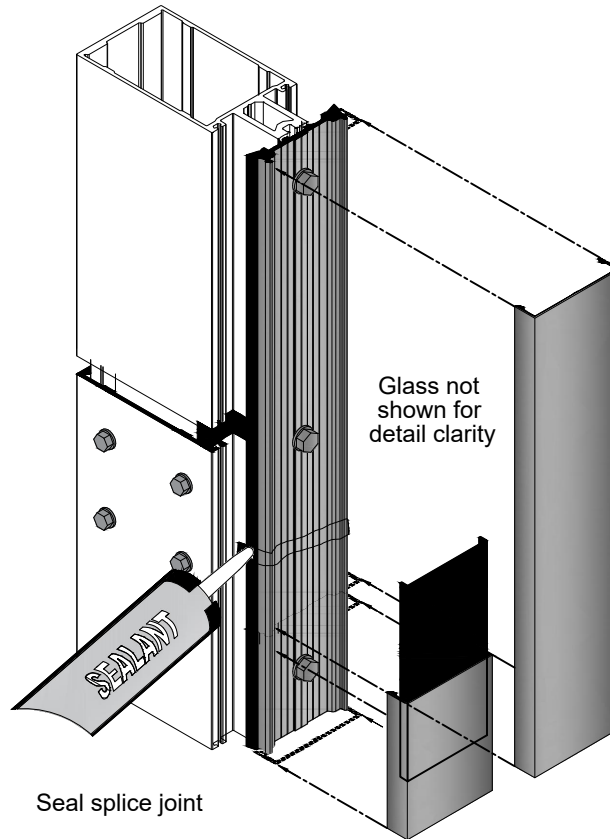

Fig. 54.2

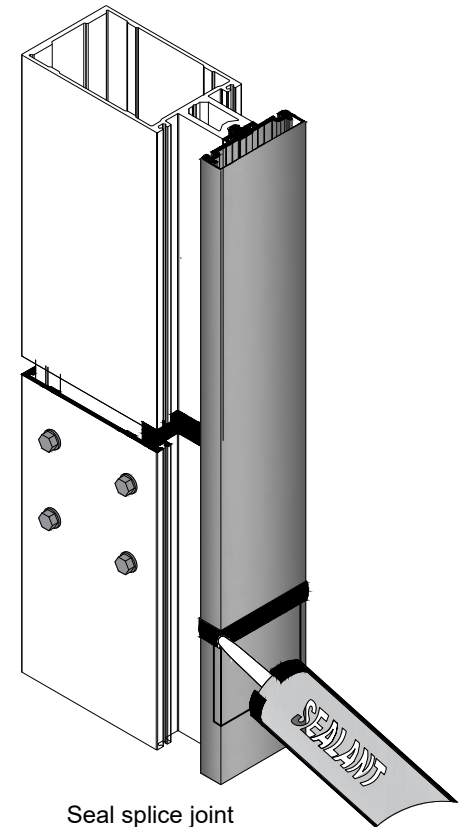
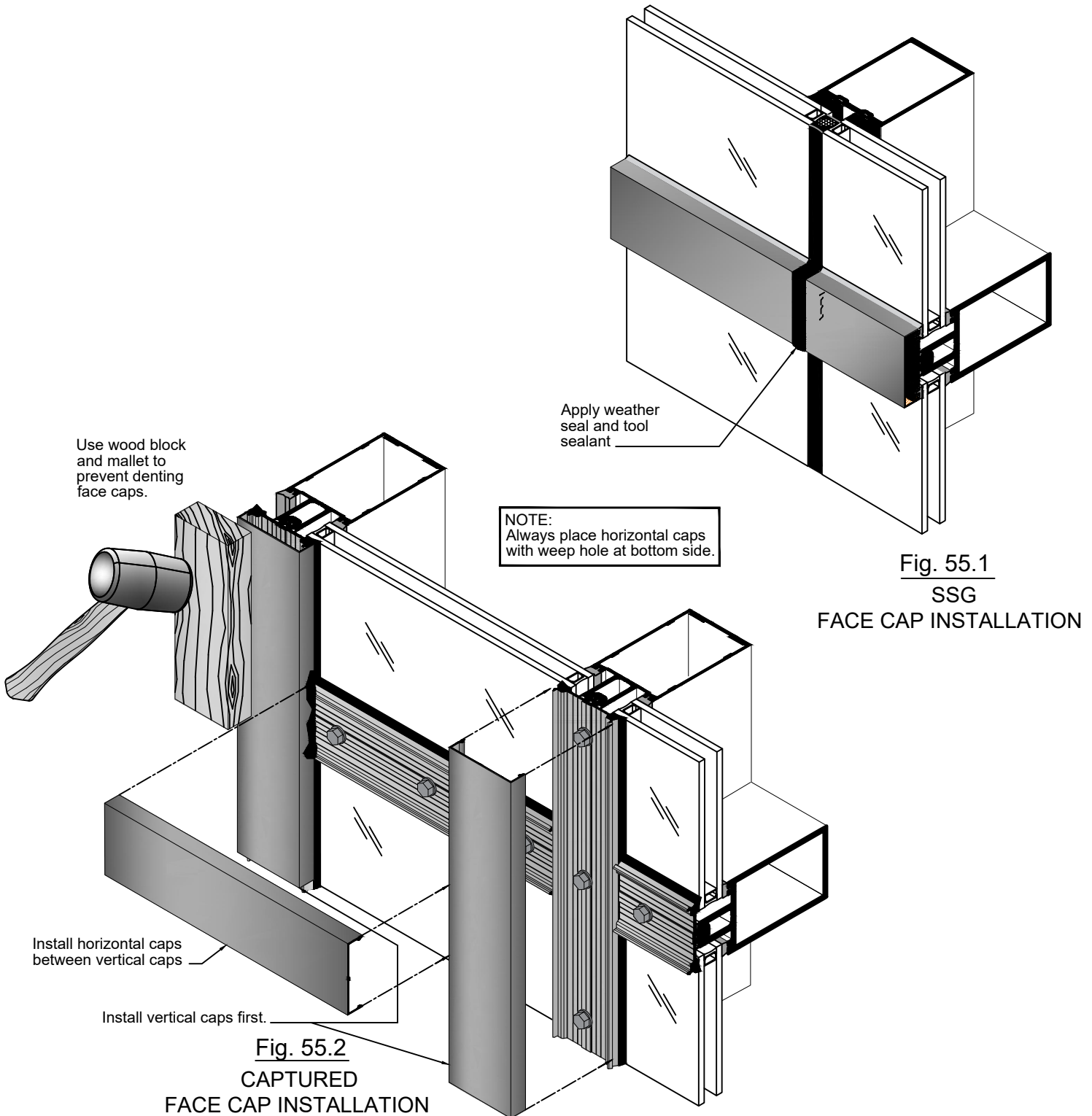

Fig. 54.3

GLAZING

Step 20: Install Pressure Plates and Face Covers (Continued)

Pressure Bar and Face Cap at multi-span mullion splice.



TRANSITION GLAZING

TRANSITION GLAZING

- A. Install vertical adaptors first, overlapping an equal amount into each glazing pocket. When adaptors are located at vertical mullion splices, discontinue adaptor at the splice. Insert a backer rod into the gap and seal thoroughly.
- B. Install horizontal adaptors with equal gaps on each end. Notching around shear block screws may be required.
- C. Seal all joints between the vertical and horizontal adaptors.

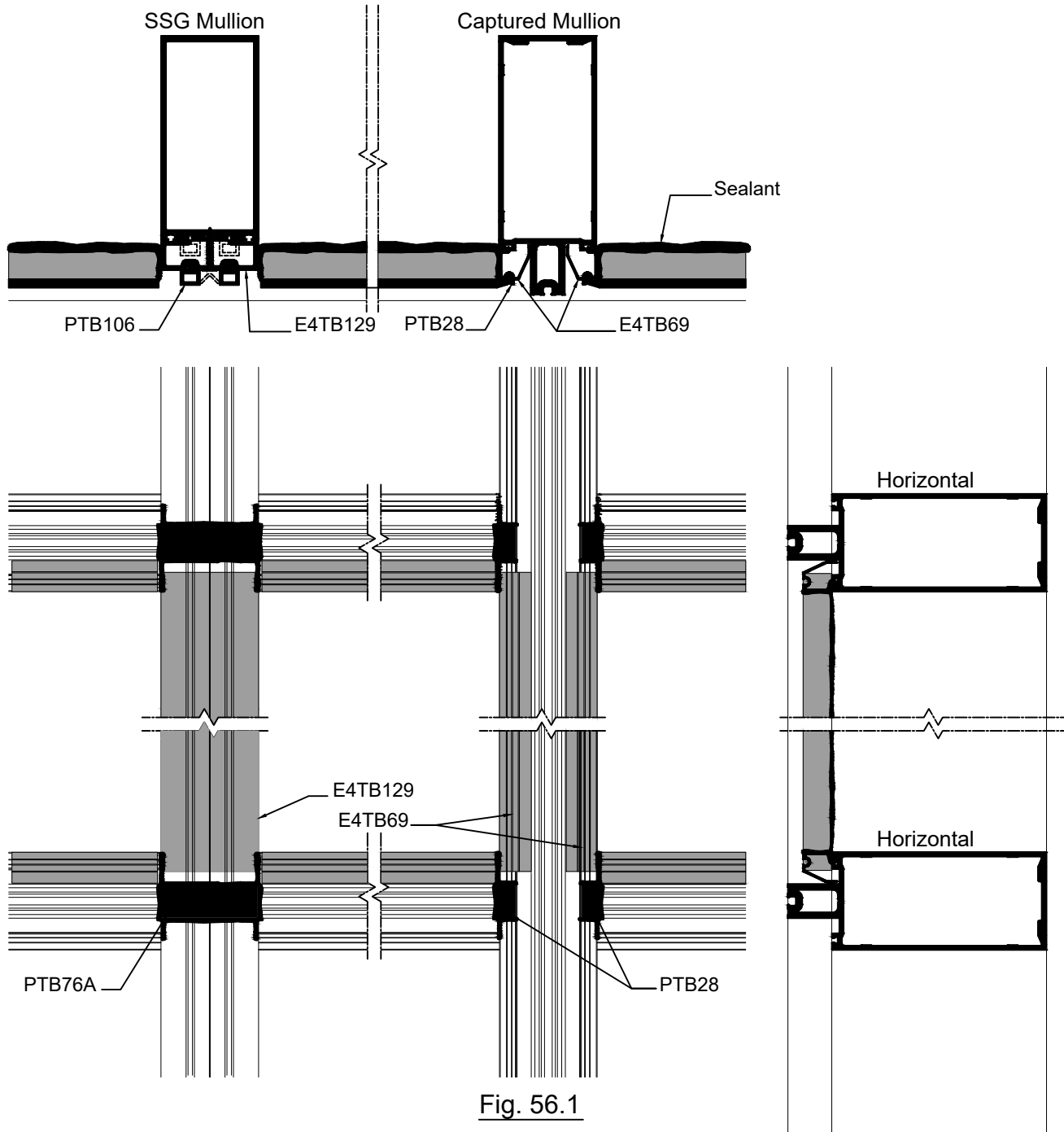

ENTRANCE FRAMING

ENTRANCE FRAMING

- A. All door framing is shipped fabricated from the factory. Curtain wall frames can be installed in the field prior to installing the doors.
- B. Curtain wall verticals and door subframes run to floor. Bed verticals in sealant and anchor to building per approved shop drawings. See Fig. 57.1 and Fig. 57.2 for possible anchoring methods. Always refer to approved shop drawings for specific requirements.

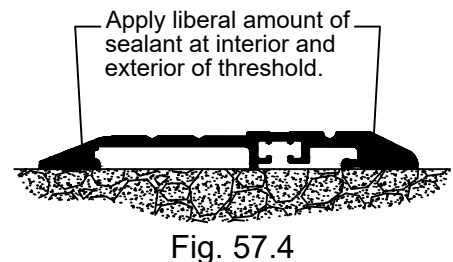
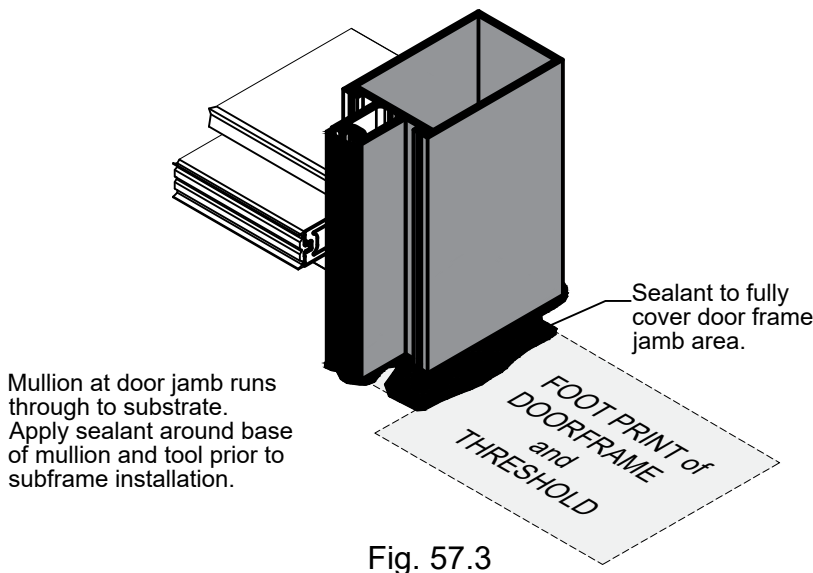
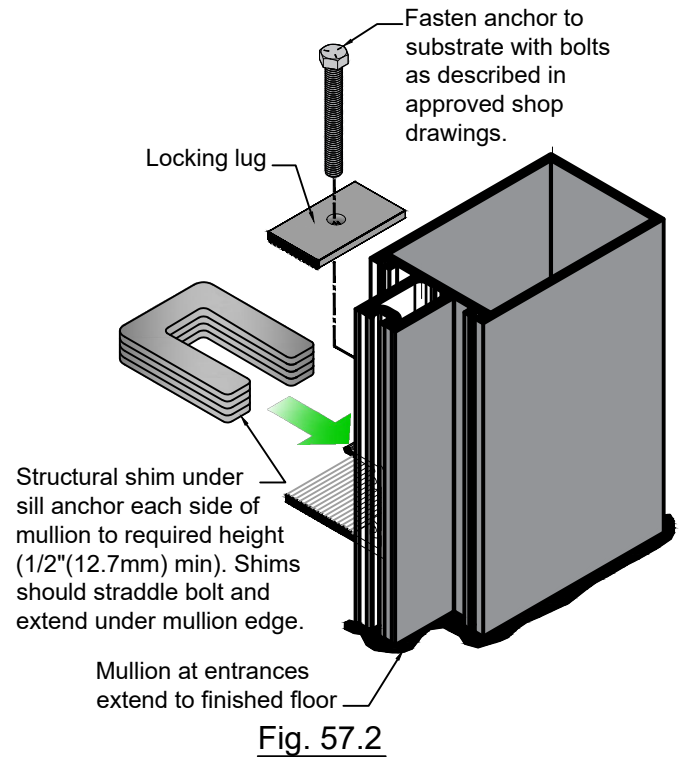
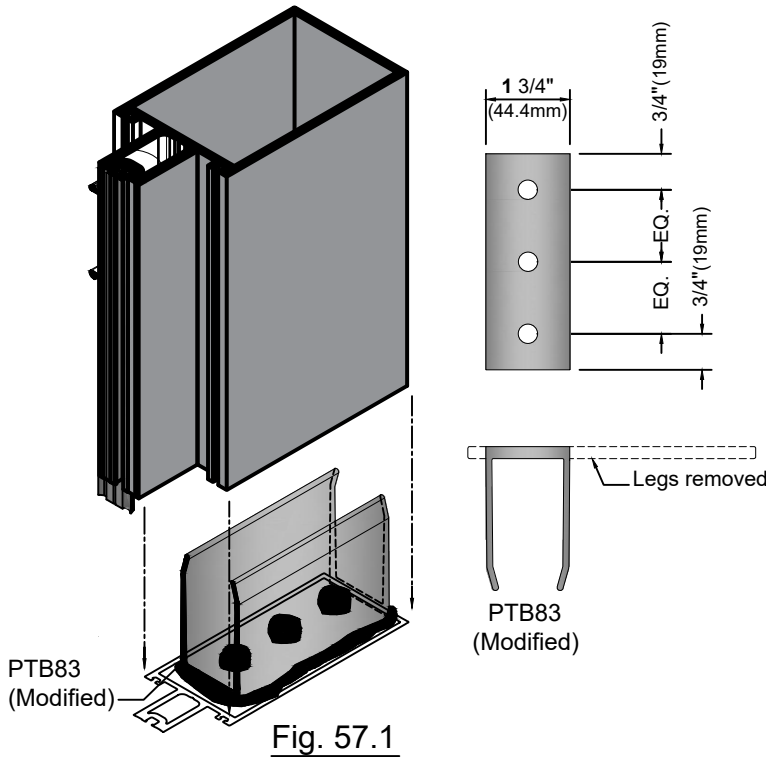

ENTRANCE FRAMING

ENTRANCE FRAMING (Continued)

C. SUBFRAME INSTALLATION

- Prep the curtain wall frame with pocket closures or as detailed on approved shop drawings.
- Prior to installing the subframe, lay down a bed of sealant where the threshold will be installed.
See Fig. 62.2 and Fig. 62.3.
- Install subframe onto curtain wall mullion, shimming equally from side to side. Attach subframe per approved shop drawings. Seal joint between subframe and curtain wall.
- Seal the top of the jamb subframe as shown in Fig. 58.3.
- Attach threshold to building per approved shop drawings.
- Install door per Tubelite's Entrances and Frames Installation Manual.

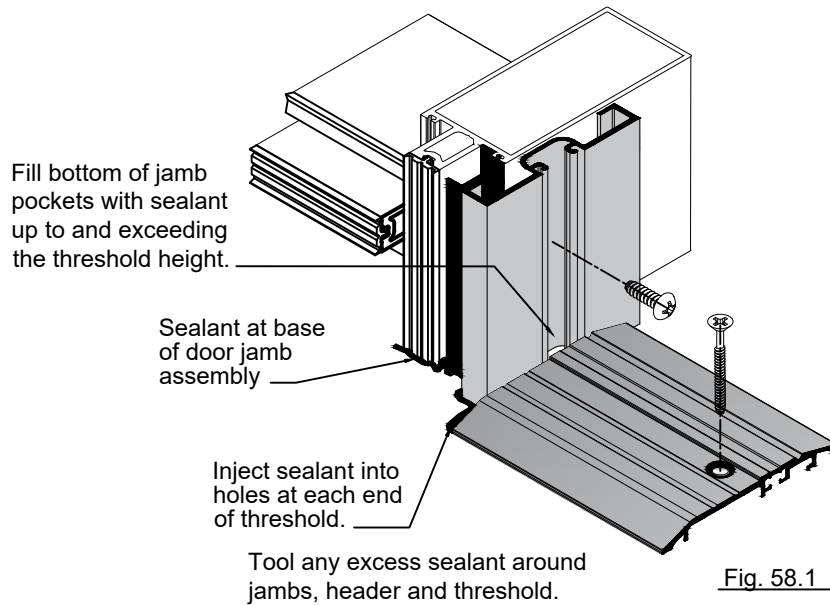

Fig. 58.1

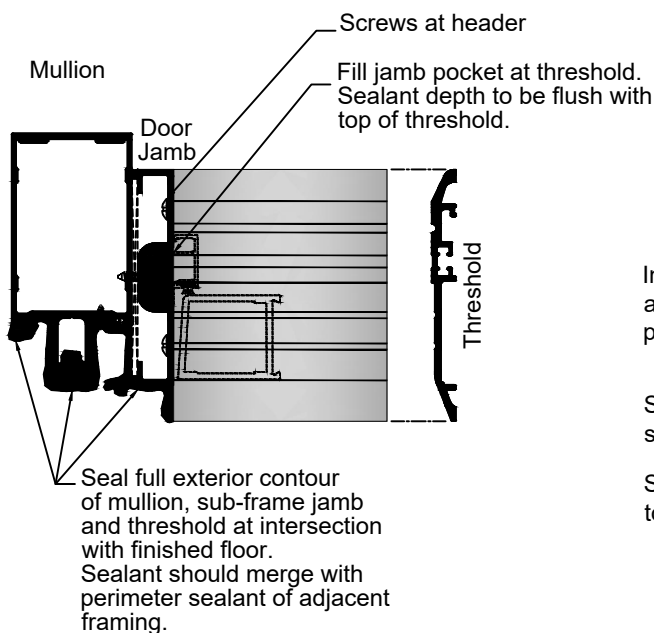

Fig. 58.2

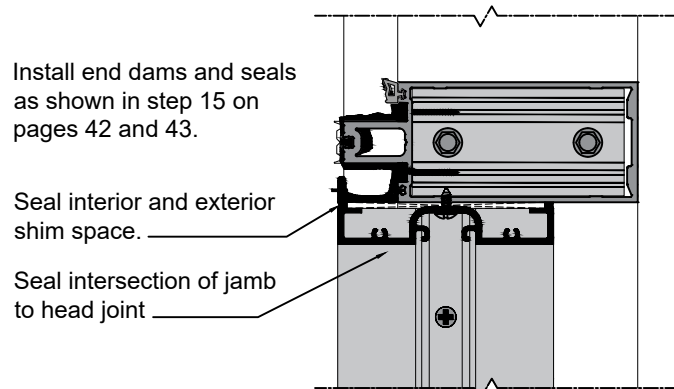

Fig. 58.3

REGLAZING

REGLAZING

- A. Reglazing is done from the exterior.
- B. Carefully remove face covers surrounding the lite to be removed.
- C. Remove vertical and horizontal pressure plates adjacent to affected lite.
- D. Temp surrounding glass in place with P1194 temporary clips per Step 19, pages 46 through 48.
- E. Remove lite of glass and gaskets from opening. Clean debris and sealant from the glass pocket and glazing reglets.
- F. Install new glass in opening per Steps 19 through 20, pages 46 through 55.

CAPTURED OUTSIDE CORNER

- A. Attach E4TB52 captured corner adaptor to the back member using S211, spaced 18"(457mm) on center.
- B. Install horizontals to corner mullion.
- C. Install water dams as noted in Step 15, pages 39 and 40.
- D. Attach glazing gaskets and isolator gaskets and seal as noted in steps 19 and 20, page 47 and 48.
- E. Install glass, pressure plates and face covers per Steps 18 and 21, pages 42 through 55.

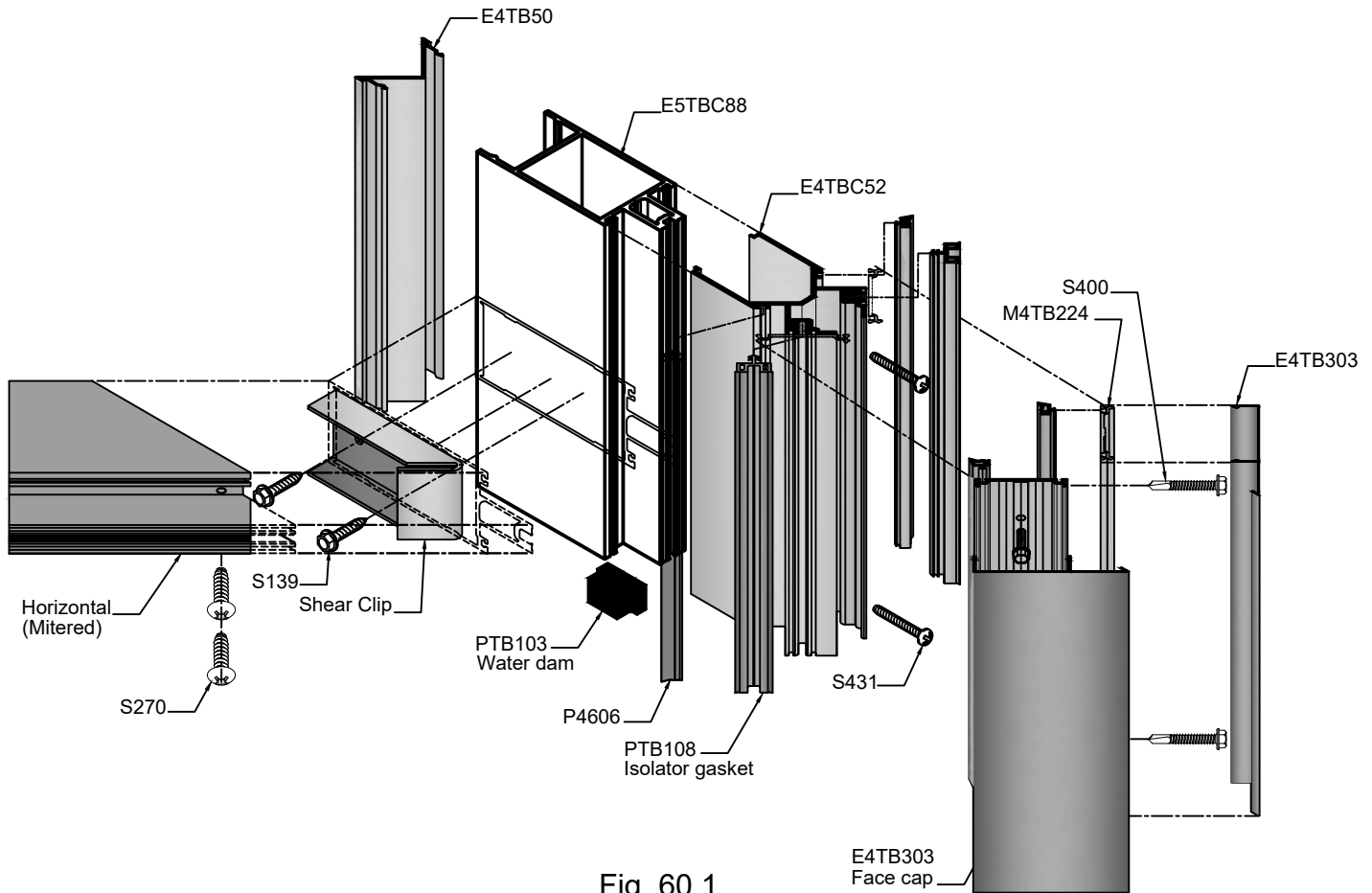

Fig. 60.1

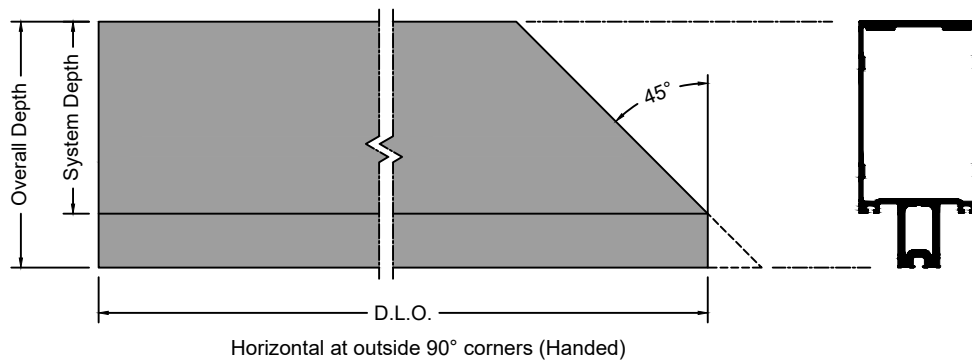

Fig. 60.2

SSG OUTSIDE CORNER

- A. Attach SSG glazed corner adaptor to the back member using S211, spaced 18”(457mm) on center.
- B. Push the PTB98 water dam into the void between horizontals. The PTB106 dam should be sealed over onto the tongue of the horizontals.
- C. Install the PTB75 SSG spacers into the vertical adaptor.
- D. Install the glass at the corner.
- E. Apply structural sealant between the glass and the mullion.
- F. Insert a foam rod to fill the void between the two corner lites of glass.
- G. Apply sealant between the lites of glass.

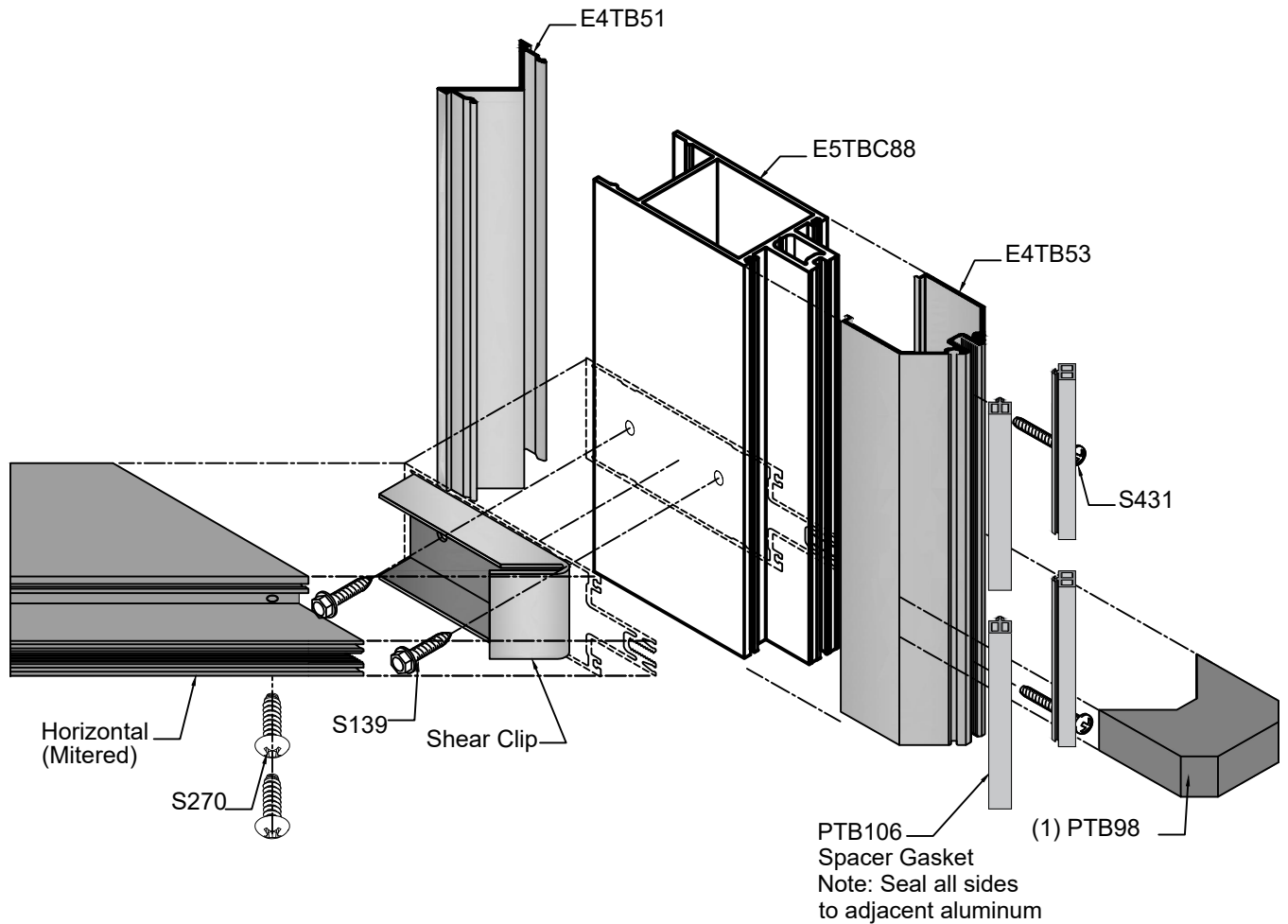

Fig. 61.1

SSG INSIDE CORNER

- A. Attach SSG glazed corner adaptor to the back member using S369 screws spaced 18"[457mm] on center.
- B. Push the PTB97 water dam into the void between horizontals. The PTB122 dam should be sealed over onto the tongue of the horizontals.
- C. Install the glass at the corner.
- D. Apply structural sealant between the glass and the mullion.
- E. Insert a foam rod to fill the void between the two corner lites of glass.
- F. Apply sealant between the lites of glass.

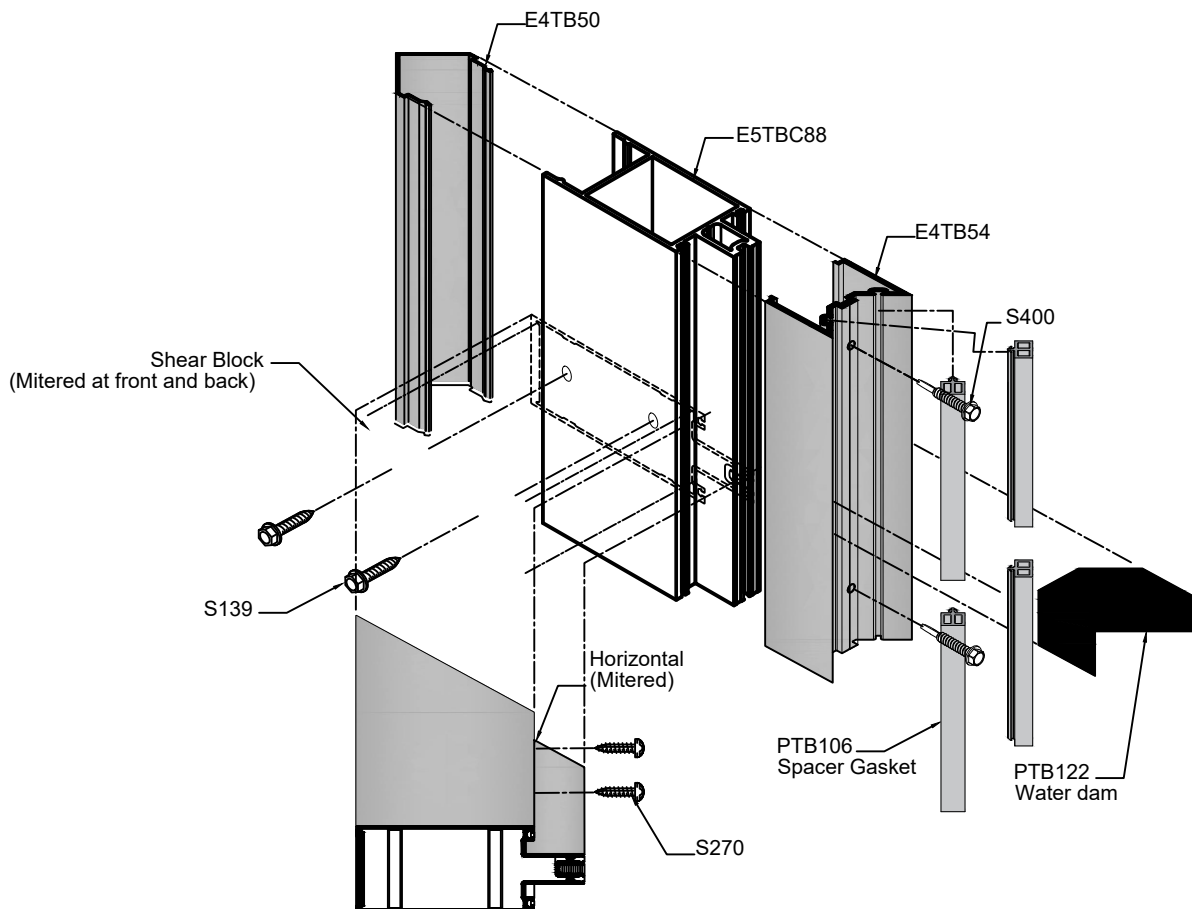

Fig. 62.1