

TYPICAL ELEVATION

**400T SERIES**  
 400 SERIES CURTAIN WALL  
 PERIMETER SHEET  
 6.25" SYSTEM DEPTH, 4.0" BACK MEMBER  
 THERMAL PRESSURE PLATE

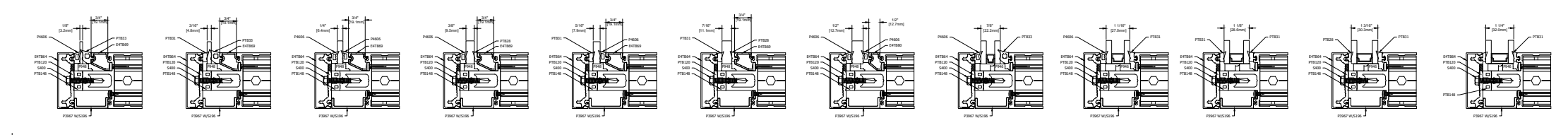
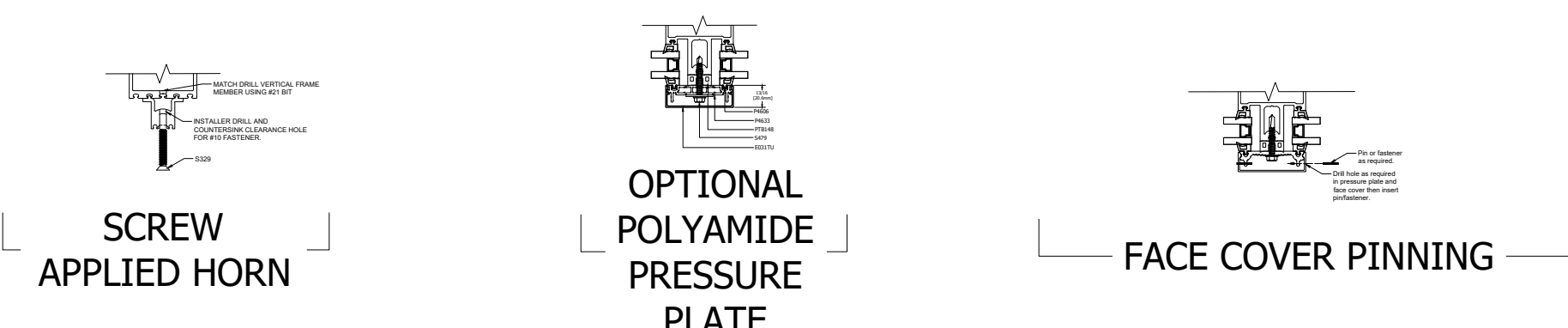
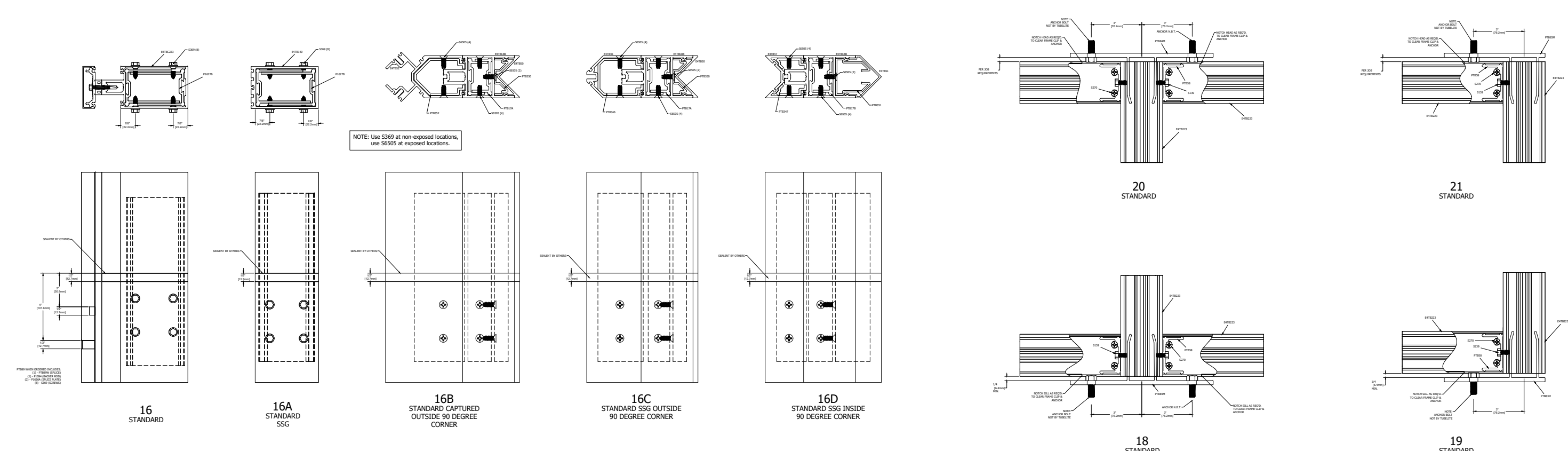
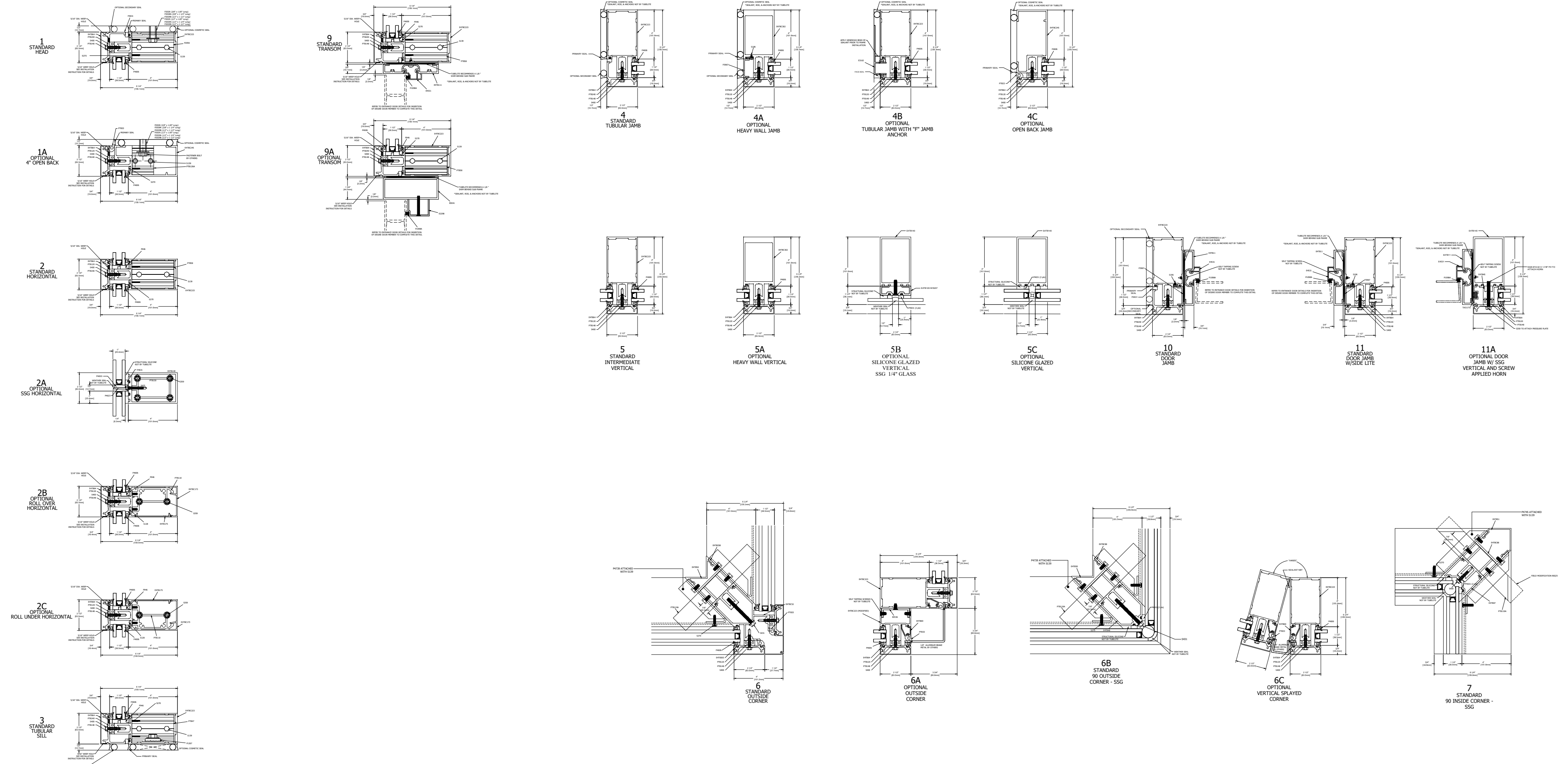

NOTE: TYPICAL GLASS BITE 1/2" FROM DLO UNLESS NOTED AT DETAIL.  
 GLAZING INFILL OPTIONS  
 GLASS SHOWN DOES NOT NECESSARILY REPRESENT FINAL CONFIGURATION. CONSULT GLASS MANUFACTURER FOR SPECIFIC GLASS MAKE UP.