

TYPICAL ELEVATION

400SS FIELD GLAZED CURTAIN WALL
 3-3/4" BACK MEMBER
 THERMAL PRESSURE PLATE

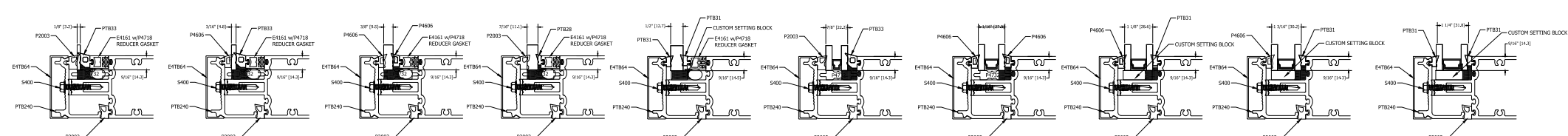

OPTIONS FOR NON-TYPICAL INFILL

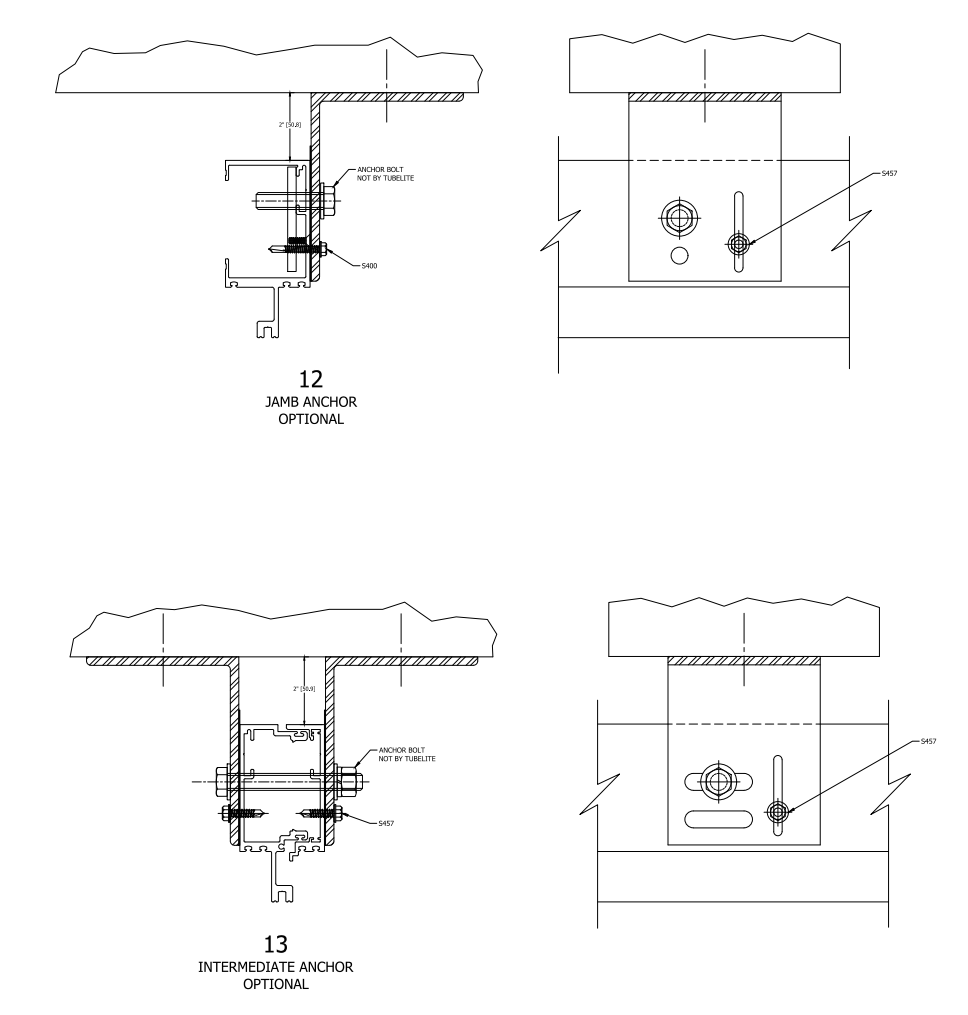
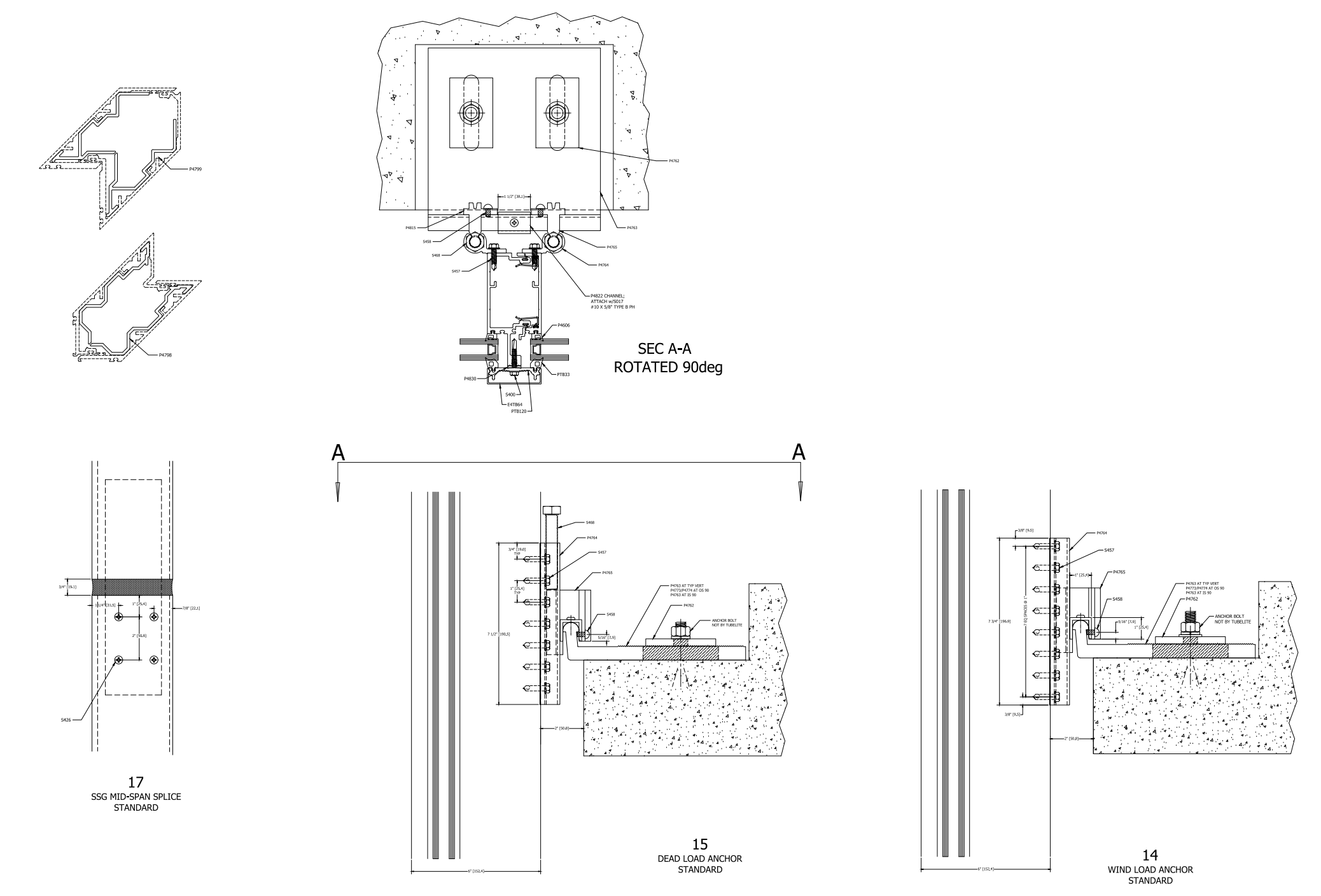
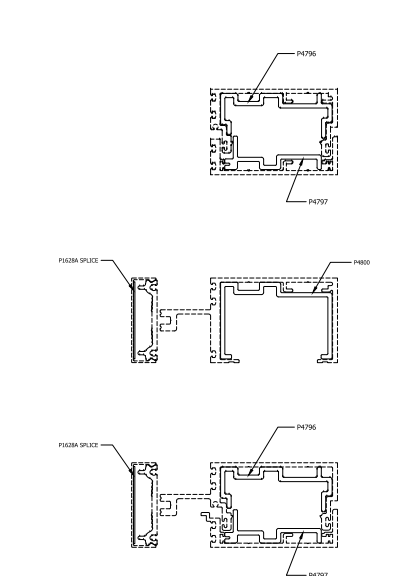
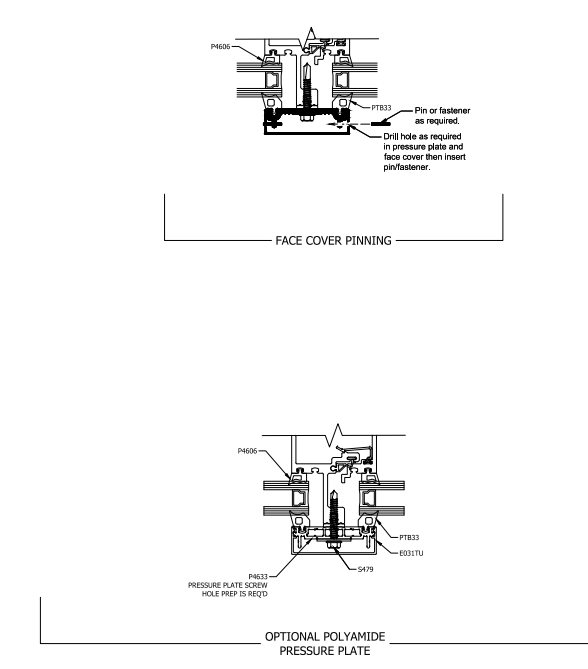
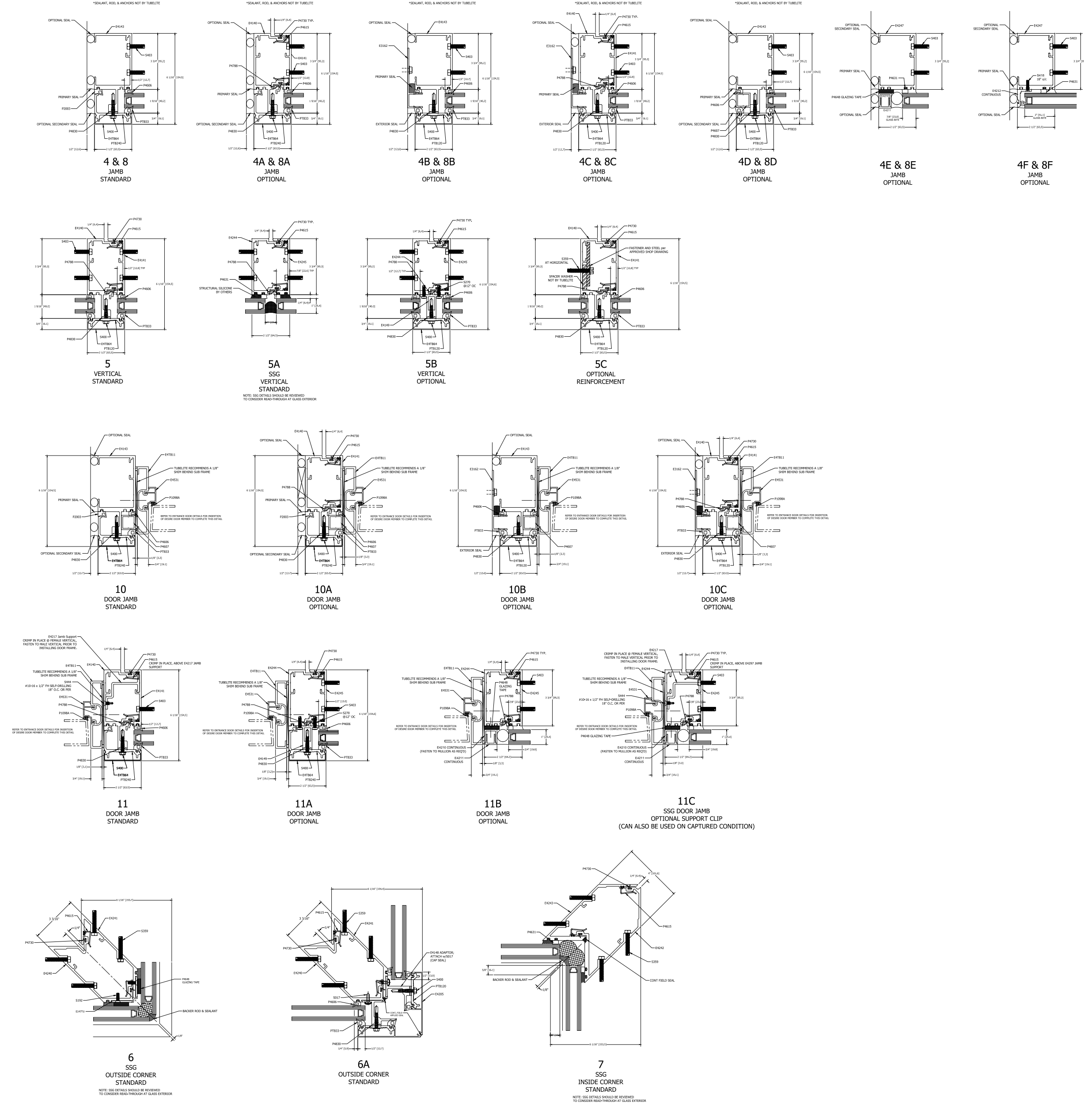
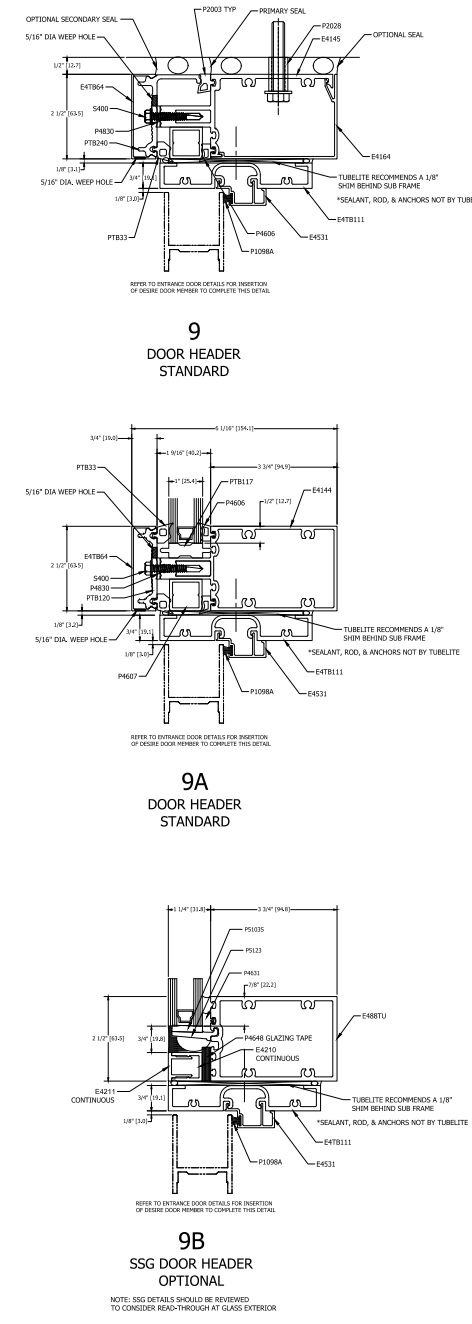
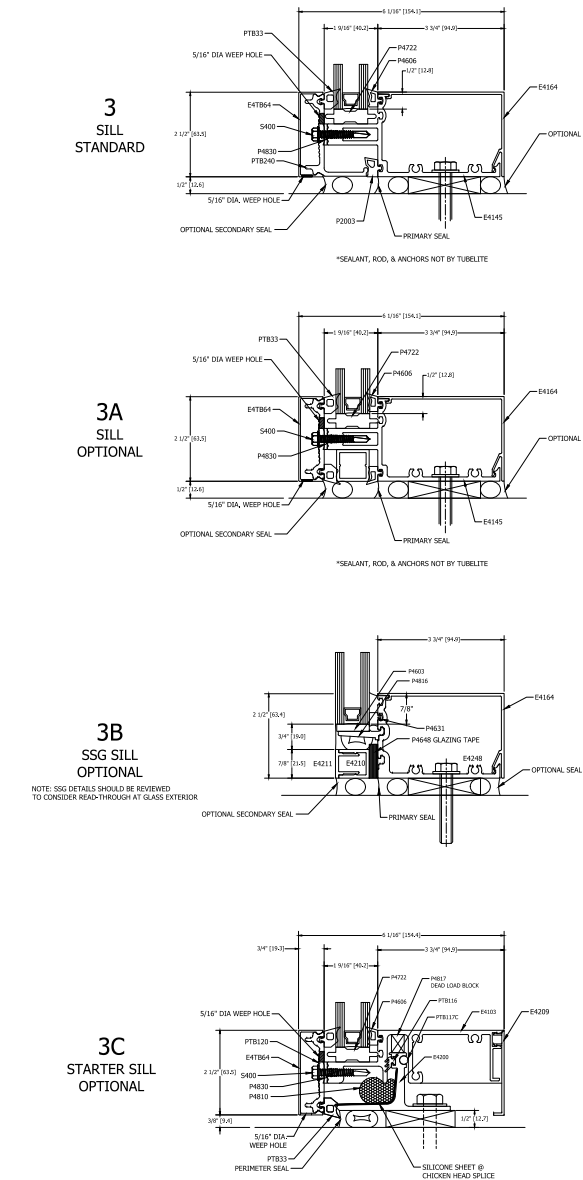
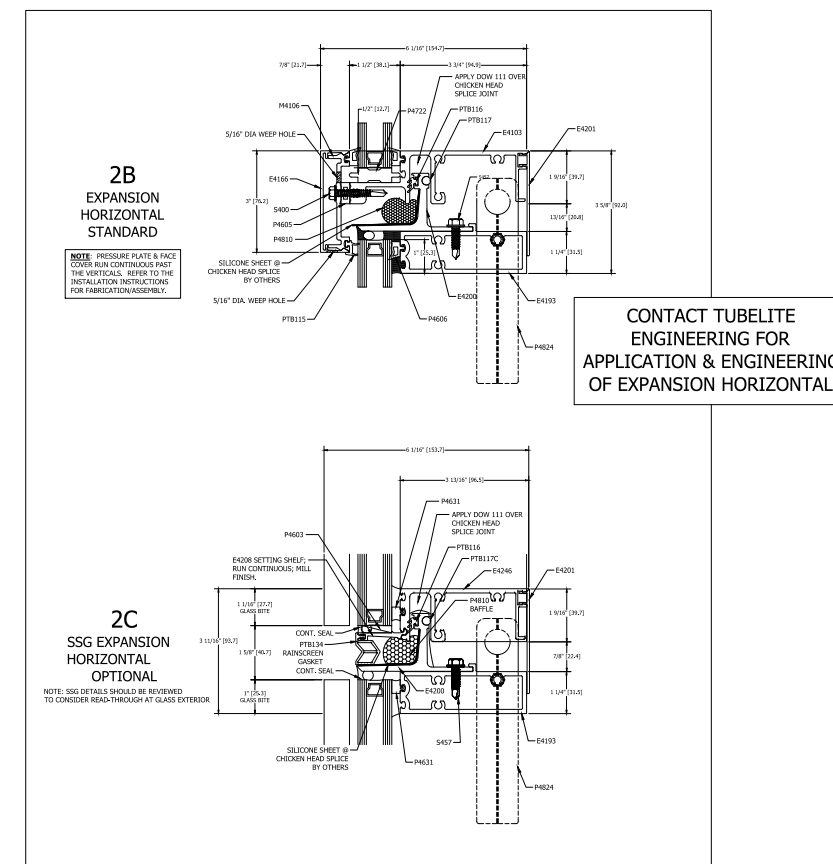
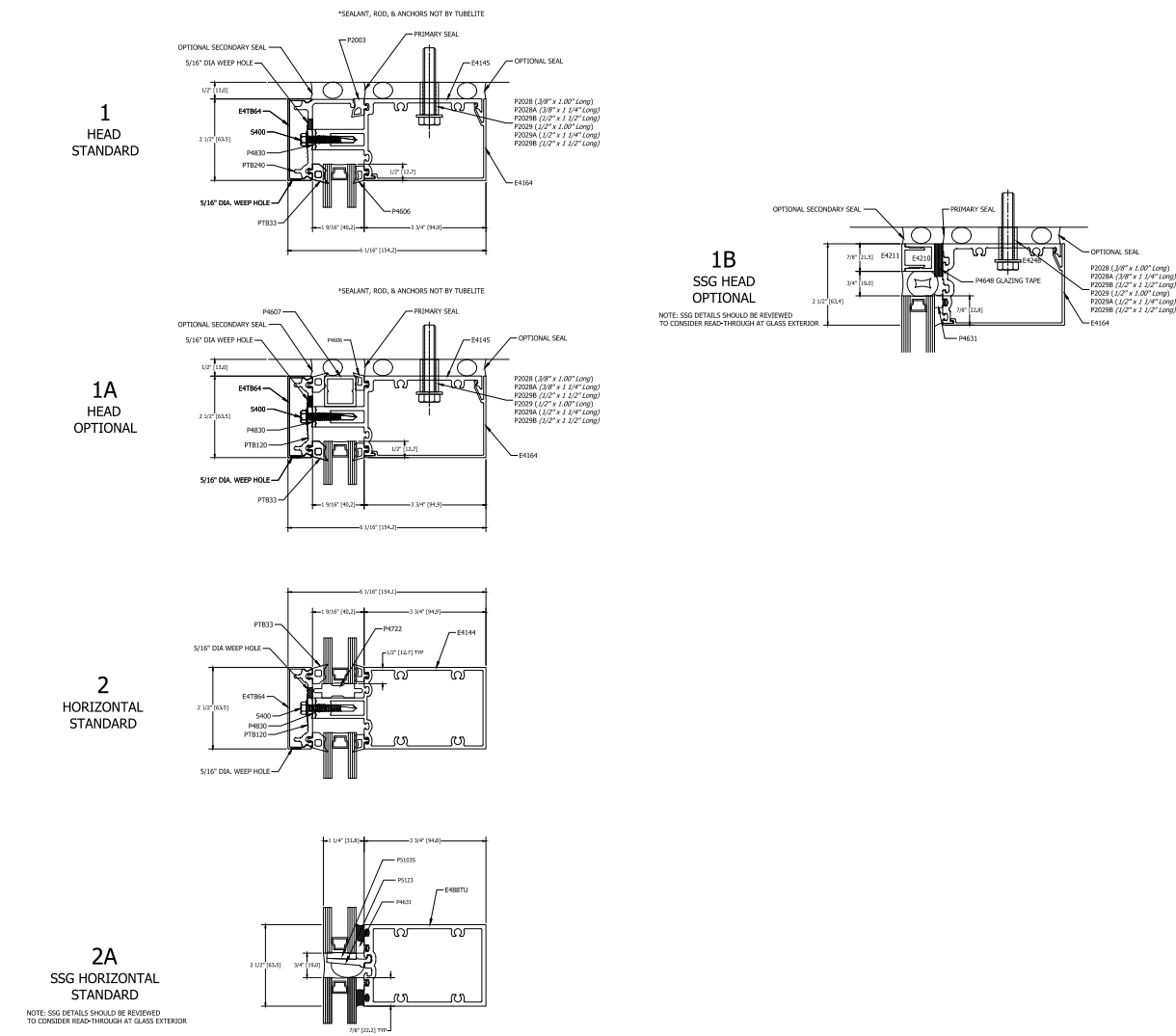
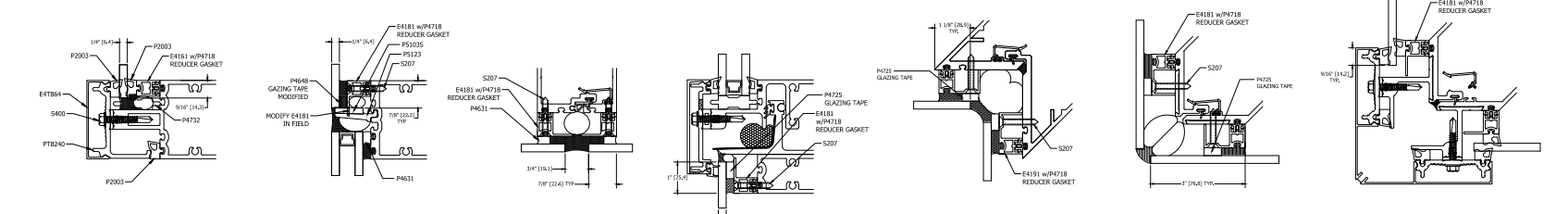

OPTIONS FOR 1/4" INFILL

GLAZING INFILL OPTIONS

GLASS SHOWN DOES NOT NECESSARILY REPRESENT FINAL CONFIGURATION. CONSULT GLASS MANUFACTURER FOR SPECIFIC GLASS MAKE UP.
 USE OF SSG VERTICALS WITH THESE GLAZING OPTIONS REQUIRE 1/4" SILICONE JOINT THICKNESS FOR OPTIMUM STRUCTURAL SILICONE PERFORMANCE. CONSULT TUBELITE ENGINEERING FOR ANY CUSTOM CONFIGURATIONS REQUIRED.



Last Revised: 4/23/2024